

Low Profile MINI® Blade Fuses Rated 58V

The Low Profile MINI® fuse has similar performance characteristics as the standard MINI® fuse. The lower overall height allows for more space and weight savings. The Low Profile MINI® fuse is designed to mate with tuning-fork terminals, which provides additional weight and material savings in fuse box designs by eliminating the need for female box terminals.

Specifications

Voltage Rating: 58 VDC
 Interrupting Rating: 1000A @ 58 VDC
 *Component Level Temperature Range: -40°C to +125°C
 **System Level Temperature Range: -40°C to +105°C
105°C is a typical system level temperature requirement.
 Terminals: Ag plated zinc
 Housing Material: PA66
 Complies with: ISO 8820-9

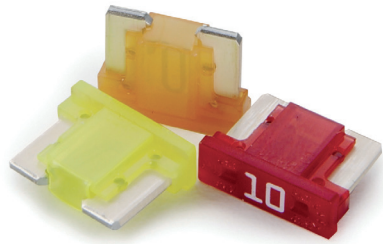

Low Profile MINI® Blade Fuses



Low Profile MINI® 10.9mm Blade Fuses

Ordering Information

Part Number	Package Size	Plating
0891xxx.NXS	5000	Ag
0891xxx.U	500	Ag
0891xxx.H	100	Ag
Low Profile MINI® 10.9mm Fuse		
0891xxx.NXWS	5000	Ag

Time-Current Characteristics

% of Rating	Opening Time Min / Max (s)
110	360,000 s / -
135	0.750 s / 120 s
200	0.150 s / 5 s
350	0.080 s / 0.250 s
600	0.030 s / 0.100 s

Ratings

Part Number	Current Rating (A)	Housing Material Color	Cold Resistance (mΩ)	I²t (A²s)
0891002_†	2		54.2	3
0891005_	5		17.21	22
089107.5_	7.5		10.65	53
0891010_	10		7.59	102
0891015_	15		4.70	198
0891020_	20		3.35	420
0891025_	25		2.56	613
0891030_	30		2.06	1110

† Only offered for the 10.0mm series.

Dimensions

Dimensions in mm

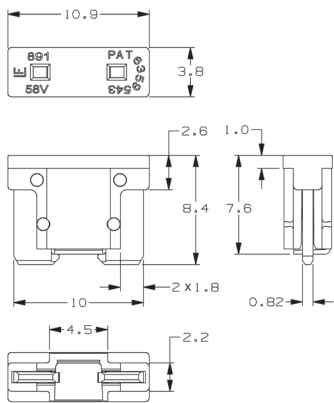

Low Profile MINI® 10.9mm

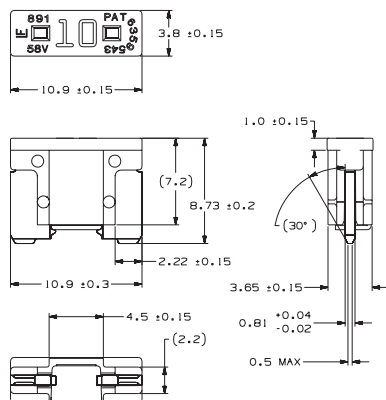

Time-Current Characteristic Curves

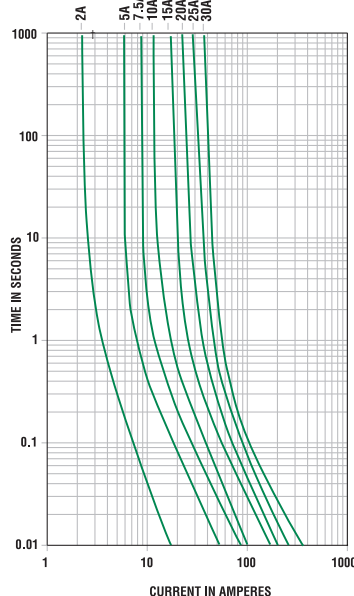

Temperature Derating Curve

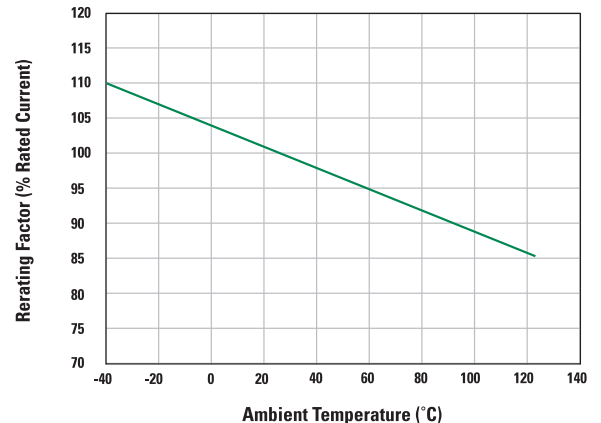

*Component Level Temperature – the maximum ambient temperature that a single fuse will survive. This does not factor-in the heat from a populated fuse box, but does include the heat from the current load with the proper derating. **System Level Temperature represents the ambient temperature of the fuse box at a location within the vehicle. The temperature within a populated fuse box (in a given location) will be higher. The limiting factor is the plating. Sn-plating's temperature limit is =130°C, and Ag-plating allows up to 150°C at the terminal interface.

Littelfuse products are not designed for, and shall not be used for, any purpose (including, without limitation, automotive, military, aerospace, medical, life-saving, life-sustaining or nuclear facility applications, devices intended for surgical implant into the body, or any other application in which the failure or lack of desired operation of the product may result in personal injury, death, or property damage) other than those expressly set forth in applicable Littelfuse product documentation. Warranties granted by Littelfuse shall be deemed void for products used for any purpose not expressly set forth in applicable Littelfuse documentation. Littelfuse shall not be liable for any claims or damages arising out of products used in applications not expressly intended by Littelfuse as set forth in applicable Littelfuse documentation. The sale and use of Littelfuse products is subject to Littelfuse Terms and Conditions of Sale, unless otherwise agreed by Littelfuse.

Mouser Electronics

Authorized Distributor

Click to View Pricing, Inventory, Delivery & Lifecycle Information:

Littelfuse:

[0891020.U](#) [0891010.NXS](#) [0891025.H](#) [0891005.H](#) [0891010.H](#) [0891030.H](#) [0891002.H](#) [0891030.U](#) [0891005.U](#)
[0891002.U](#) [089107.5NXS](#) [0891010.U](#) [0891015.H](#) [089107.5U](#) [0891005.NXS](#) [0891020.NXS](#) [0891015.NXS](#)
[0891025.U](#) [0891030.NXS](#) [0891015.U](#) [0891020.H](#) [0891002.NXS](#) [0891025.NXS](#) [089107.5H](#) [0891025.NXWS](#)
[0891010.NXWS](#) [0891005.NXWS](#) [089107.5NXWS](#) [0891020.NXWS](#) [0891002.NXWS](#) [0891030.NXWS](#)
[0891015.NXWS](#)