

# ITT Cannon APD Series Connectors



## HEAVY DUTY BAYONET CONNECTORS TO ISO 15170

ITT Cannon APD series connectors were designed to meet ISO 15170 and European DIN 72585 requirements for heavy duty trucking and are now commonly used in industrial equipment and harsh environments. The ITT Cannon APD series is resistant to brake and transmission fluids as well as to oil, grease, salt, dirt and mud. ITT Cannon APD heavy duty connectors have quick-mating bayonet coupling, lock wire holes for added security, and fold-over clamshell endbells. Common variations include 2 pin connector, 3 pin connector, 4 pin connector, 6 pin connector and 7 pin connector types. For full product details on APD connectors, see the specifications below.

### APPLICATIONS

- Sensors
- ABS brake control
- Valve actuators
- Magnetic vehicle control systems
- Vehicle-use monitoring equipment

### FEATURES

**RUGGED PLASTIC HOUSING** APD's are extremely resistant to salt spray, automotive oils, grease and fluids, and maintain their integrity in challenging environments.

**THREE-POINT BAYONET COUPLE SYSTEM** Besides being quick-mating with a third-of-a-turn, these connectors also provide an audible and tactile feedback that they are mated properly.

**COLOR-CODED MATED PAIRS** When multiple connectors must be used in the same area and mis-mating may occur, color-coded connectors should be used. There are four codings available, black (standard), green, gray, and blue, that are uniquely polarized by color using four internal keys and keyways allowing only connectors of the same color to mate.

**MULTIPLE CABLE HANDING OPTIONS** Low cost straight and right angle snap-over-clamshell style endbells can be used with cable ties for strain relief or put over plastic annular ring conduit (8.5mm or 10mm). The rear of the connector is also designed to use heat shrink tubing or slide on annular ring conduit (20mm).

### TECH SPECS

#### MATERIALS & FINISHES

Shell	High quality, plastic PBT housing, PA coupling nut
Seals	HNBR interfacial O-rings and elastomeric wire seals
Contacts	Copper alloy
Plating	Tin, silver or gold-plated







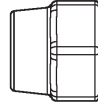
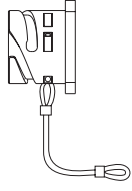

#### ELECTRICAL DATA

Working Voltage	48 Vdc max
Test Voltage	1000 Vac
Current Rating	From 16 to 25 Amps maximum; 240 Amps for power version
Wire Range Sizes	28 - 0 AWG (0.08-53.4 mm <sup>2</sup> )
Contact Resistance	3 milliohms maximum
Insulation Resistance	5000 megohms minimum

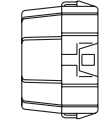
#### MECHANICAL DATA

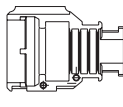
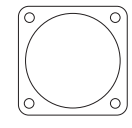
Operating Temperature	-40°C to 140°C (-40°F to 284°F)
Sealing	IP69K
Mating Life	50 cycles minimum
Vibration / Shock	147 - 500Hz 30g's; 500 -2000Hz 20g's
Number of Circuits	1-7, 1-4, 1-2 or single circuit power
Approvals	DIN 72585

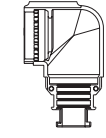
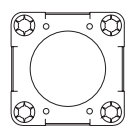

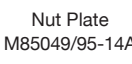

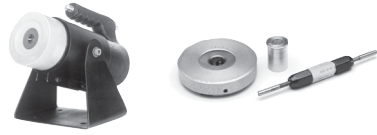

HOW TO ORDER

	SOCKET CONTACTS				USE PIN CONTACTS		SEALS	SEALING RANGE	ACCESSORIES	
	PLUGS		FLANGED RECEPTACLES	JAM NUT RECEPTACLES	CODE/COLOR	ENDBELL			OTHER	
 1 Circuit 245 Amps Max.	121583-0012 APD-5BSH	121583-0014 APD-5APH	121583-0016 APD-5CPH	5 Blue	351-8697-003	.560 - .622 (14.2 - 15.8)	 Seal Nut 217-8516-010 or PG16 Conduit Adapter BFIL-P167 for size 17 PMA Conduit	 Plug Dust Cap 121583-0022		
					351-8697-002	.484 - .547 (12.3 - 13.9)				
					351-8697-001	.409 - .472 (10.4 - 12.0)				
	121583-0013 APD-6BSH	121583-0015 APD-6APH	121583-0017 APD-6CPH	6 Red	351-8697-009	.330 - .394 (8.4 - 10.0)				
	351-8697-005	.228 - .303 (5.8 - 7.7)								
	980-8605-002 Contact O Ring	-								
 2 Circuit 74 Amps Max.	121583-0025 APD-1BSH8-2	121583-0026 APD-1APH8-2	121583-0027 APD-1CPH8-2	5 Black	351-8697-013 One Cavity Closed	.146 - .196 (3.7 - 5.0)	 Receptacle Dust Cap 121583-0021			
					351-8697-008	.292 - .366 (7.4 - 9.3)				
					351-8697-007	.225 - .287 (5.7 - 7.3)				
					351-8697-000	.166 - .228 (4.2 - 5.8)				
					273-8506-012 16GN5824 Green	.170 - .188 (4.3 - 4.8)				
 4 Circuit 30 Amps Max.	121583-0000 APD-1BSK2	121583-0004 APD-1APK2	121583-0008 APD-1CPK2	1 Black	273-8506-005 121668-0032 10RD5821 Red	.056 - .078 (1.4 - 2.0)	 Straight 058-8578-100 for 8.5mm 058-8578-102 for 10mm	 Panel gasket 075-8503-000 -55° to 125°C (-67° to 257°F)		
	121583-0001 APD-2BSK2	121583-0005 APD-2APK2	121583-0009 APD-2CPK2	2 Gray	273-8506-006 121668-0033 15BL5822 Blue	.079 - .114 (2.0 - 2.9)				
	121583-0002 APD-3BSK2	121583-0006 APD-3APK2	121583-0010 APD-3CPK2	3 Green	273-8506-007 121668-0034 15WH5823 White	Wire Hole Filler				
	121583-0003 APD-4BSK2	121583-0007 APD-4APK2	121583-0011 APD-4CPK2	4 Blue						
 7 Circuit 16 Amps Max.	121583-0018 APD-1BS7	121583-0020 APD-1AP7	121583-0019 APD-1CP7	1 Black	273-8506-008 121667-0022 10GR3940 Gray	.056 - .078 (1.4 - 2.0)	 Right Angle 058-8578-101 for 8.5mm 058-8578-103 for 10mm	 Mounting Plate 066-8516-005		
	120110-0024 APD-1BS6	120110-0060 APD-1AP6	121583-0061 APD-1CP6			273-8506-009 121667-0023 10YE3940 Yellow			.075 - .082 (1.9 - 2.1)	
 6 Circuit 16 Amps Max.	-	120110-0083 APD-1AP6-spl O Ring Grooved Shell	-		273-8506-010 121667-0024 10RD3940 Red	.048 - .062 (1.2 - 1.6)	 Nut Plate M85049/95-14A			
					273-8506-011 121667-0025 10WH3940 White	Wire Hole Filler				

All dimensions in inches (millimeters in parentheses) unless otherwise stated.

# HOW TO ORDER



	CONTACTS				TOOLS				
	AWG	MM2	PIN CONTACTS	SOCKET CONTACTS	CRIMP TOOL	LOCATOR	EXTRACTION TOOL		
 1 Circuit 245 Amps Max.	0	53.4	030-8614-000 ▲	031-8521-000 ▲	400BHD	APD0 Kit NOTE: Please provide wire sample when ordering	CET-APD#0-Pin 121586-5192 CET-APD#0-Skt 121586-5193 NOTE: housings can not be reused		
	-	50.0	030-8592-000 ▲	031-8561-000 ▲					
	2	35.0	030-8614-020 ▲	031-8521-020 ▲					
	4	25.0	030-8614-010 ▲	031-8521-010 ▲					
	-	16.0	030-8614-030 ▲	031-8521-030 ▲					
	M8x13 Threaded Stud		031-8531-008 ▲	-				-	-
	M8x24 Threaded Stud		031-8531-009 ▲	-				-	-
 2 Circuit 74 Amps Max.		16.0	430-8645-007 ▲	031-8646-001 ▲	400BHD	APD8 Kit NOTE: Please provide wire sample when ordering	CET-APD-2 121586-5149		
	6	-	430-8645-002 ▲	031-8646-003 ▲					
	8	-	430-8645-003 ▲	031-8646-002 ▲					
	-	10.0	430-8645-009 ▲	031-8646-011 ▲					
	-	6.0	430-8645-000 ▲	031-8646-010 ▲					
	AWG	MM2	 REEL OF 3000 CONTACTS/LEFT HAND FEED						
 4 Circuit 30 Amps Max.	16 - 20	0.5 - 1.5	121668-0026 reel 031-8717-046 loose 121668-0021 reel♦ 031-8717-049 loose♦	121668-0125 reel 031-8717-149 loose 121668-0022 reel♦ 031-8717-152 loose♦	121586-5242		192900-0176		
	14 - 16	1.5 - 2.5	121668-0027 reel 031-8717-047 loose	121668-0126 reel 031-8717-150 loose♦					
			121668-0029 reel 031-8717-050 loose♦	121668-0128 reel 031-8717-153 loose♦					
12 - 14	2.5 - 4.0	121668-0028 reel 031-8717-048 loose	121668-0127 reel 031-8717-151 loose						
		121668-0025 reel 031-8717-051 loose♦	121668-0124 reel 031-8717-154 loose						
 7 Circuit 16 Amps Max.   6 Circuit 16 Amps Max.	16 - 20	0.5 - 1.5	192900-0000 3K reel 192900-0002 loose	192900-0001 3K reel 192900-0003 loose	APD16 CRIMPTOOL		192922-1450		
	14 - 28	.08 - 2.5	⇒ See page 66						
	18 - 16	0.75 - 1.5	330-8672-021 machine loose piece press in	-	AF8	120090-0163	Non-Removable		
	-	0.35 - .075	330-8672-019 machine loose piece press in	-					

▲ = Silver Plated, ♦ = Gold Plated, all others Tin Plated

**PLUG**

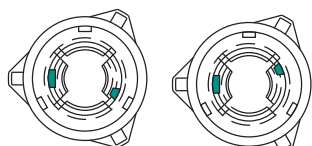
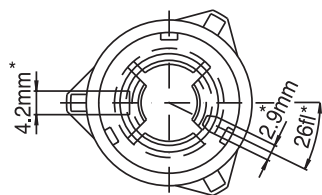
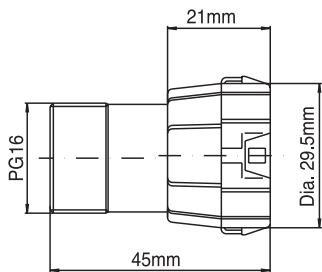

Code 5      Code 6

**FLANGE RECEPTACLES**

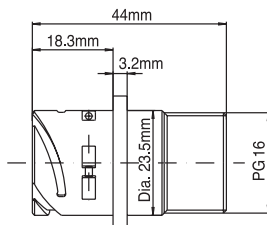

Panel Cutout  
Panel Thickness 3mm Max.

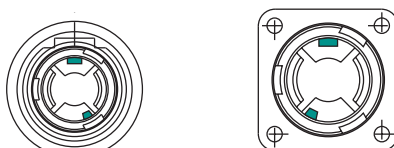
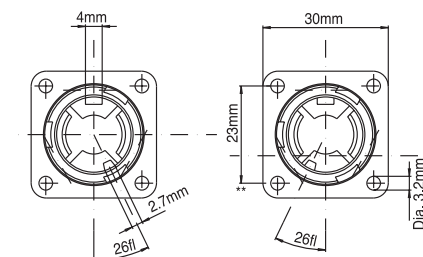

Code 5      Code 6

**JAM NUT RECEPTACLES**

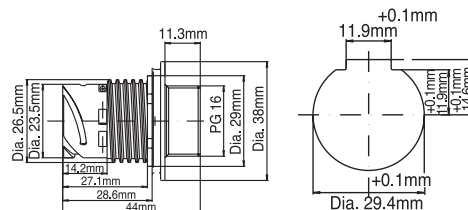

Panel Cutout  
Panel Thickness 4mm Max. / .8mm Min.

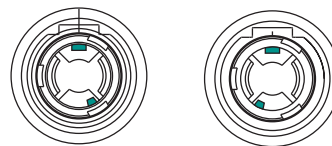
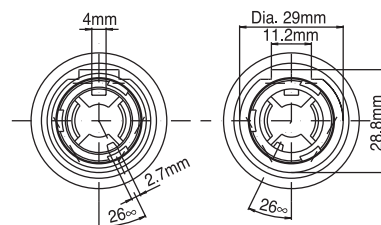

Code 5      Code 6

**WIRE SEALS/WIRE SEAL NUT**



351-8697-00\*

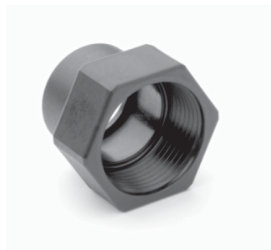

217-8516-010

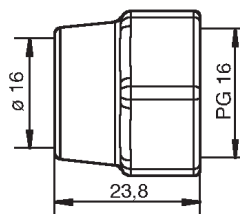

217-8516-010

SEAL NUMBER	351-8697-003	351-8697-002	351-8697-001	351-8697-009	351-8697-005
WIRE SEALING RANGE	.560 - .662 (14.2 - 15.8)	.484 - .547 (12.3 - 13.9)	.409 - .472 (10.4 - 12.0)	.330 - .394 (8.4 - 10.0)	.228 - .303 (5.8 - 7.7)

All dimensions in inches (millimeters in parentheses) unless otherwise stated.

PLUG

FLANGE RECEPTACLES

JAM NUT RECEPTACLES

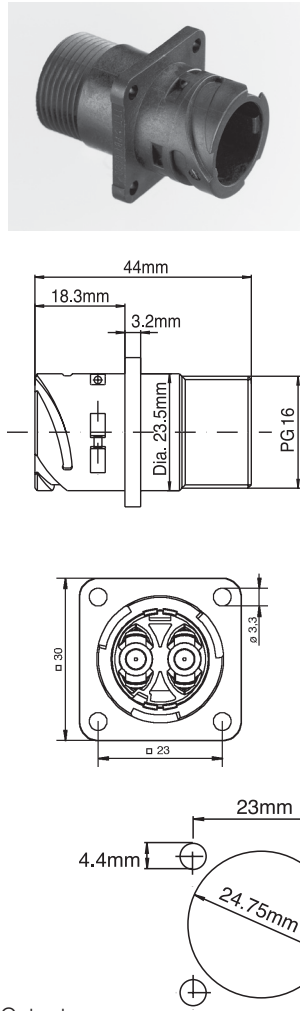
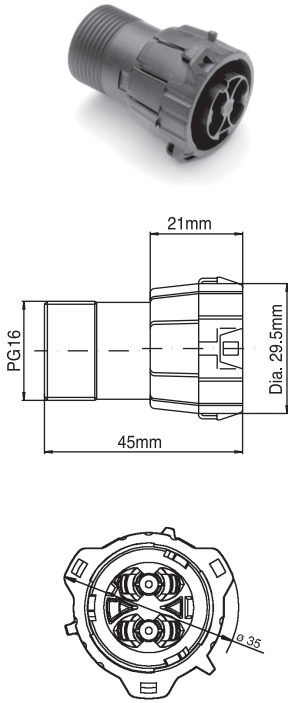

Panel Cutout  
Panel Thickness 3mm Max.

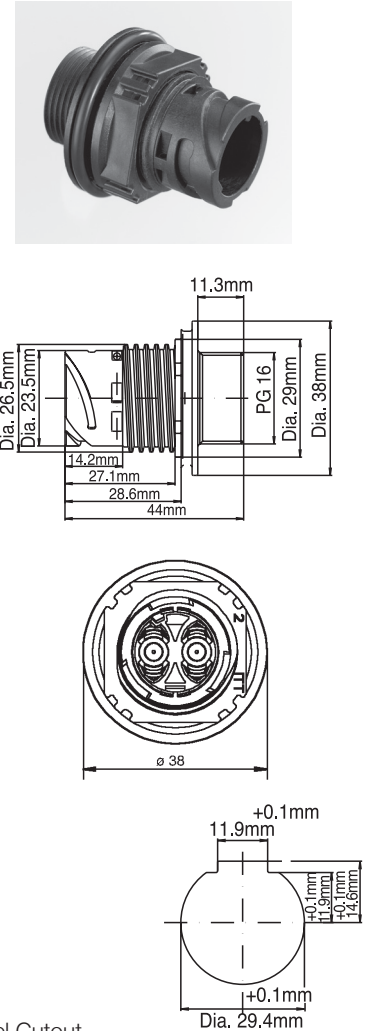

Panel Cutout  
Panel Thickness 4mm Max. / .8mm Min.

WIRE SEALS/WIRE SEAL NUT

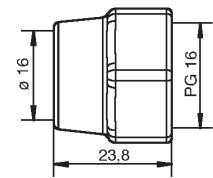
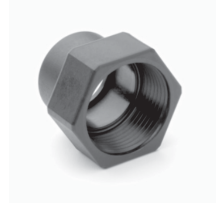
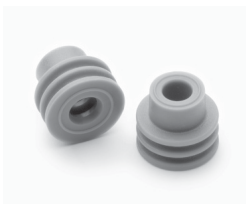

217-8516-010

217-8516-010

	INDIVIDUAL WIRE				
PART NUMBER	273-8506-012 16GN5824 Green	351-8697-008	351-8697-007	351-8697-000	351-8697-013
WIRE SEALING RANGE	.170 - .188 (4.3 - 4.8)	.292 - .366 (7.4 - 9.3)	.225 - .287 (5.7 - 7.3)	.166 - .228 (4.2 - 5.8)	.146 - .196 (3.7 - 5.0)

All dimensions in inches (millimeters in parentheses) unless otherwise stated.

APD4 DIMENSIONS

PLUG

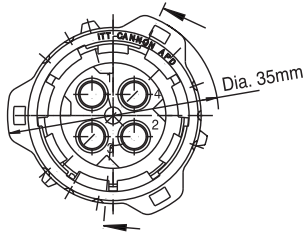
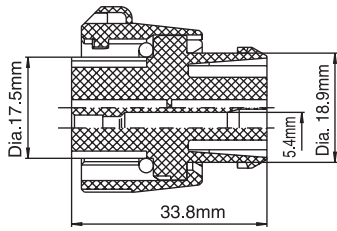

FLANGE RECEPTACLES

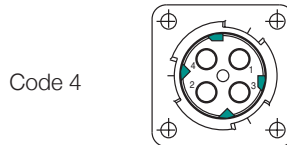
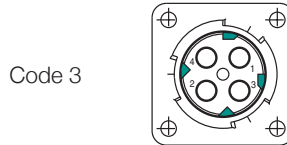
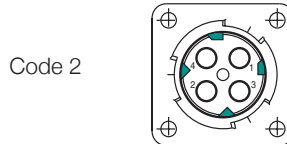
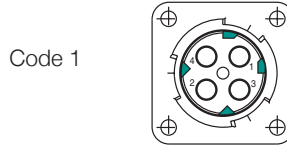
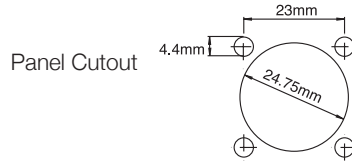
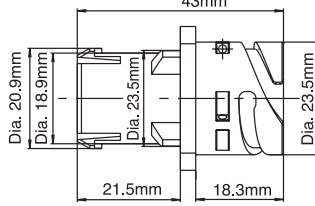
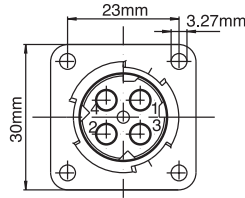

JAM NUT RECEPTACLES

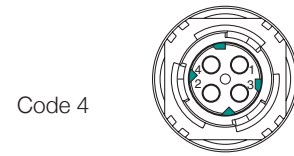
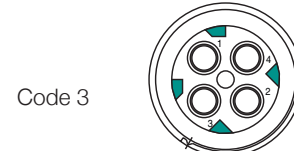
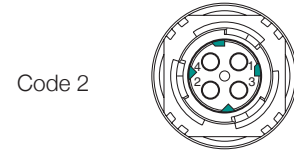
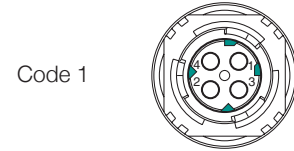
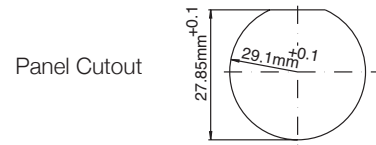
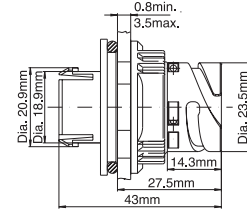
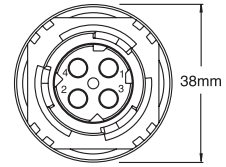

WIRE SEALS

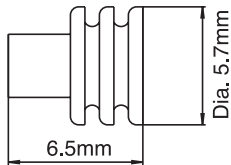

PART NUMBER	Individual bag of 5000 description	273-8506-005 121668-0032 10RD5821 Red	273-8506-006 121668-0033 15BL5822 Blue	273-8506-007 121668-0034 15WH5823 White
WIRE SEALING RANGE		.056 - .078 (1.4 - 2.0)	.079 - .114 (2.0 - 2.9)	Wire Hole Filler

All dimensions in inches (millimeters in parentheses) unless otherwise stated.

PLUG

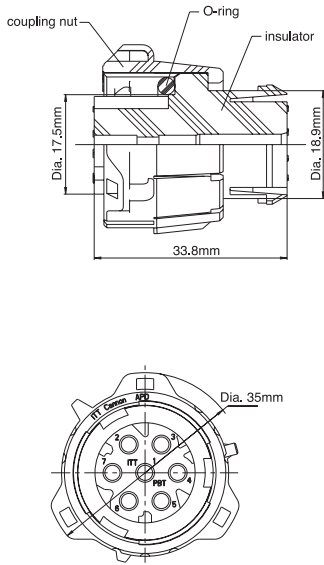

FLANGE RECEPTACLES

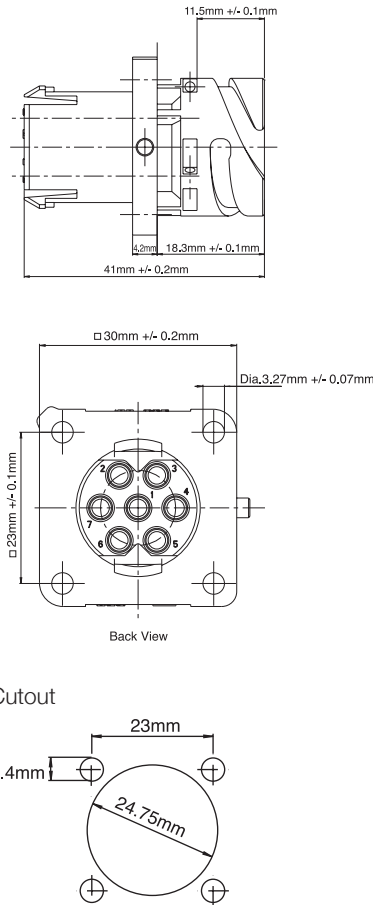

JAM NUT RECEPTACLES

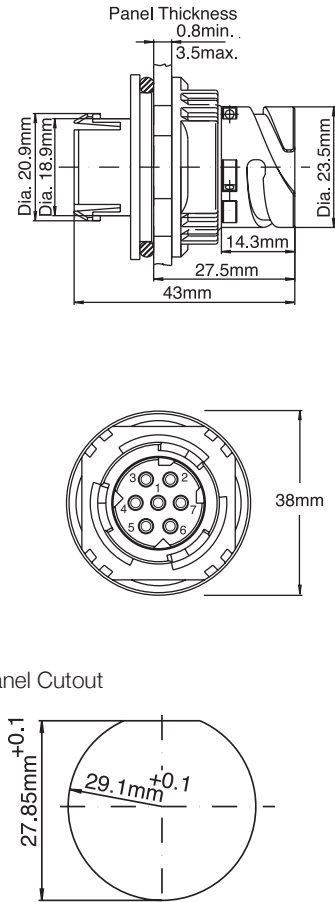

WIRE SEALS



PART NUMBER	Individual bag of 5000 description	273-8506-008 121667-0022 10GR3940 Grey	273-8506-009 121667-0023 10YE3940 Yellow	273-8506-010 121667-0024 10RD3940 Red	273-8506-011 121667-0025 10WH3940 White
WIRE SEALING RANGE		.056 - .078 (1.4 - 2.0)	.075 - .082 (1.9 - 2.1)	.048 - .062 (1.2 - 1.6)	Wire Hole Filler

APD STRAIGHT ENDBELLS

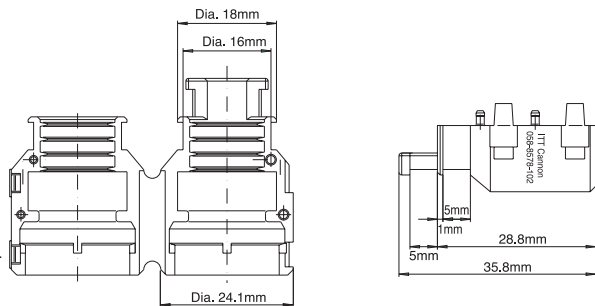

APD 90° ANGLE ENDBELLS

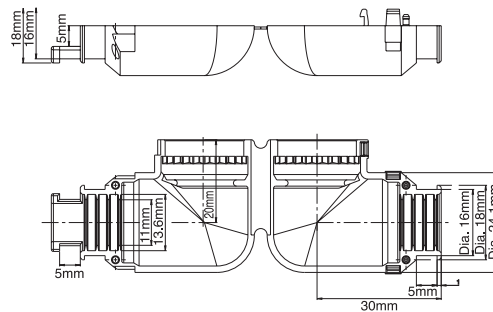

All dimensions in inches (millimeters in parentheses) unless otherwise stated.

4 & 7 WAYS (STAMPED, FORMED/PRESSED AND ROLLED CONTACT)

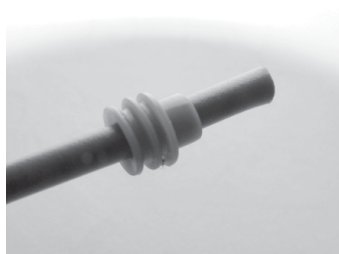

**Note:** The tools listed are for the seal captivation crimp tool, please contact us for more information on the non-captivating style crimp tool.

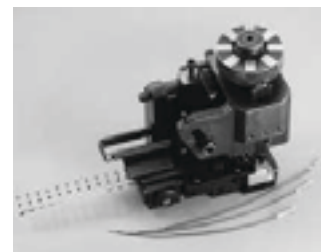

**STEP 1:** Slide individual wire seal up the wire. Isopropyl alcohol will help. Seal may be used either way, depending on contacts and tools used. It can be crimped into place with the contact or slid down to rear of the contact. Cutting the wire on a diagonal may also assist in sliding the seal on the wire.

**STEP 2:** Strip wire to proper length. ⇒ See page 66 - 67.  
**Note:** Depending on the orientation of the wire seal, it may be easier to strip the wire before applying the seal.

**STEP 3:** Load contact into proper hole on the locator.

**STEP 4:** Close the tool just enough to grip the contact.

**STEP 5:** Insert the stripped wire into the contact from the wire side. The wire seal should be located flush with the tip of the wire insulation.

**STEP 6:** Cycle the tool. The tool will not open until the contact has been completely crimped.

**STEP 7:** Remove the crimped contact from the tool and inspect the crimp. See Stamped Contacts in the Crimp inspection sections on ⇒ page 55. Note: Mini-Applicators for industry standard crimp presses are available to order. Please contact us with contact and wire information.

1, 2 & 6-WAY (MACHINED CONTACTS)



**STEP 1:** Slide rear accessories up the cable/wire in the proper order: securing nut, then wire seal.

**STEP 2:** Strip the wires to length.

6-WAY (CRIMPED WITH THE STANDARD AF8 HAND TOOL AND PROPER LOCATOR)

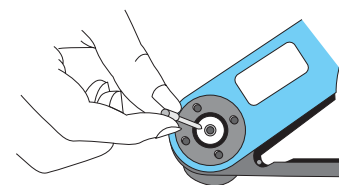
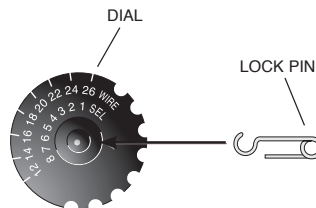
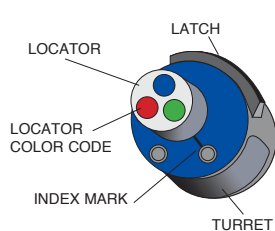
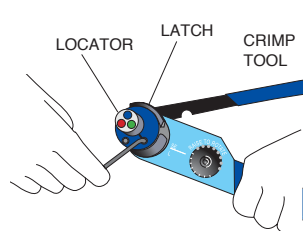

**STEP 1:** Open the crimp tool by squeezing the handles. Push the latch on turret to pop the locator. Attach the turret to the crimp tool using the two captive hex bolts in the turret.

**STEP 2:** Select the proper locator position for your contact by rotating the locator until the proper color is aligned with the index mark. Push locator back down until it snaps into position. Adjust dial for proper wire gauge.

**STEP 3:** To change the dial setting, remove the lock pin and lift center of dial. Turn to the desired wire gauge. Replace lock pin on dial.

**STEP 4:** Cycle the tool before inserting the contact to be sure the tool is in the open position. Drop the contact, mating end first, into the crimp cavity of the tool. Squeeze the tool handle just enough to grip the contact without actually crimping it.



6-WAY (CRIMPED WITH THE STANDARD AF8 HAND TOOL AND PROPER LOCATOR)

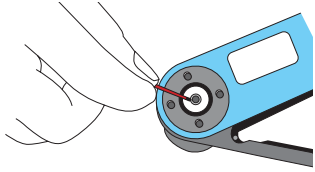

**STEP 5:** Insert the stripped wire into the contact with a slight twisting motion. Be sure all wire strands are inside the contact. Squeeze the handle to cycle the tool. The handle will not release until the contact is completely crimped.

**STEP 6:** Remove the crimped contact. Pull on the wire slightly to be sure it is properly crimped. Be sure the contact is not bent or damaged in any way.

**STEP 7:** Visually inspect the crimp. See machined contacts drawing below.

CRIMP INSPECTION (MICRO SECTIONS)

Enlargement of micro section allows for final judgment of crimp quality. This test is recommended whenever new tools or new types of wire are used.

FOR STAMPED CONTACTS

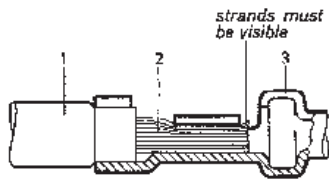

Correct Crimp

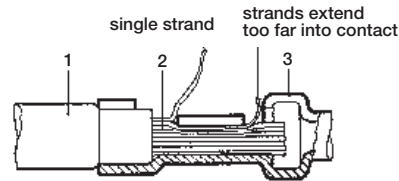

Incorrect Crimp

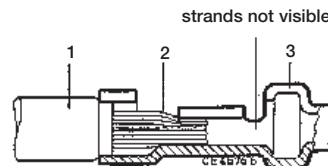

Incorrect Crimp

- 1 - Insulation
- 2 - Strands
- 3 - Contact

FOR MACHINED CONTACTS

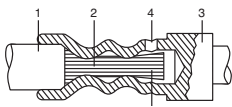

Correct Crimp

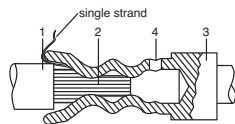

Incorrect Crimp

- 1 - Insulation
- 2 - Strands
- 3 - Contact
- 4 - Wire inspection hole

2 & 1-WAY

Due to the wide variety of wire types and styles, it is highly recommended that a 3 to 4 foot (1m) sample of wire and contacts be submitted to PEI-Genesis when ordering. These samples will be sent to the factory for crimp depth determination and go/no-go gauge creation. Warning: Crimps that have not been verified may cause high resistance, hot spots, and localized heating that can damage the insulating components.

➔ See page 3 for product safety information.



**STEP 1:** Use filtered, clean, dry (do not use air oiler) air supply at 70 to 125 PSI (80PSI nominal) at 1 to 2 CFM.

**STEP 2:** Insert the proper locator into the hole in the front face of the 400BHD pneumatic crimp tool and align the notch until the locator is fully inserted.

**Note:** Failure to use a locator may cause the contact to slide off the wire into the tool, and if cycled, may cause damage to the crimp tool.

**STEP 3:** Put the crimp dies onto the face of the crimp tool, making sure to align the hole on the rear with the die locating pin on the front of the tool. If done correctly, the die assembly will sit flush to the front face of the crimp tool.

**STEP 4:** Install the cover nut O ring on the front face of the crimp die.

2 & 1-WAY



**STEP 5:** Screw on the cover nut to secure the dies to the tool. Do not over tighten. This will compress the cover nut O ring, restricting the crimp dies. This is needed because the contact will lengthen slightly during crimping as the metal of the contact is displaced by the indenters.

**STEP 6:** The crimp kits typically come with go/no-go gauges and it is recommend that the dies be check when locator/dies are changed and at a suitable interval to ensure proper crimp quality.

**STEP 7:** Cycle the tool once before crimping to verify that the tool and dies are in proper working order by depressing the actuator button or optional foot pedal actuator.

**STEP 8:** Insert the mating face of the contact into the locator.



**STEP 9:** Carefully insert the stripped wire into the crimp pot with a slight twisting motion. All strands of the wire must go into the crimp pot of the contact.

**STEP 10:** Fully cycle the tool by depressing the crimp actuator button / pedal.



**STEP 11:** Release the actuator and remove the crimped contact.

**STEP 12:** Visually inspect the crimp. ⇨ See page 55 for machined contacts drawing.

CRIMP INSPECTION

Enlargement of micro section allows for final judgment of crimp quality. This test is recommended whenever new tools or new types of wire are used.

CONTACT INSERTION



**STEP 1:** No tools are required to insert the standard contacts (all but the 6-way press-in contacts). Simply insert the contact into the proper contact cavity until the contact snap into place. Pull lightly on the wire or threaded contact to verify proper seating.

FINAL ASSEMBLY



**STEP 1:** Slide any non-captivated wires seals into the rear wire seal cavities. For 4, 6 & 7-way connectors, a snap over endbell can be used.



**STEP 2:** For 2-way and 1-way connectors, slide the seal, seal nut or conduit terminator up to the rear of the connectors and tighten.

CONTACT EXTRACTION

All contacts are removable, but 1-way connector housings cannot be re-used and must be replaced with new housings. Contacts can be removed from the housings using the appropriate extraction tool. The tool is placed over the mating end of the contact and the sleeve is rotated slightly as it is pushed into the connector.

**IMPORTANT:** Make sure the depth indicating line on the tool is even with the mating face of the connector before depressing the plunger to avoid damage to connector and contact. Light pressure on the plunger then ejects the contact from the rear of the connector.

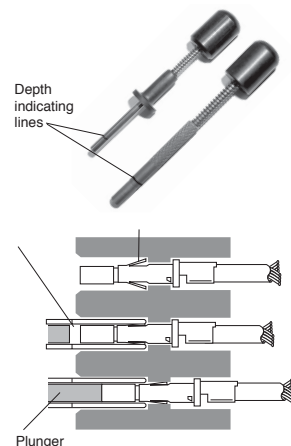

1. Contact in connector.
2. Extraction tool compresses tines.
3. Plunger pushes contact out rear of connector.