

Number of contacts

Mounting height

9-37
50

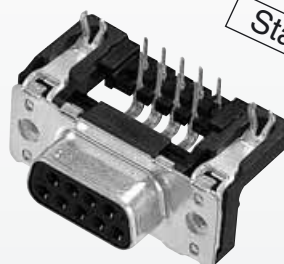
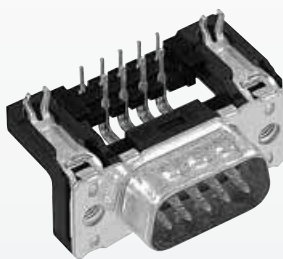
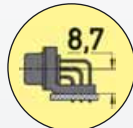

Standard Versions

Stamped solder pins, angled with grounding board locks

D-Sub - S

Identification	No. of contacts	Part No.				
Performance levels Explanations see page 02.02 Other performance levels on request		Performance level 3		Performance level 2		
Male connector metal shell with dimples		2.84 mm pitch		2.84 mm pitch		
	9	09 65 163 781 . 1)		09 65 163 681 . 1)		
	15	09 65 263 781 . 1)		09 65 263 681 . 1)		
	25	09 65 363 781 . 1)		09 65 363 681 . 1)		
	37	09 65 463 781 . 1)		09 65 463 681 . 1)		
		2.54 mm pitch		2.54 mm pitch		
	9	09 65 162 781 .		09 65 162 681 .		
	15	09 65 262 781 .		09 65 262 681 .		
	25	09 65 362 781 .		09 65 362 681 .		
	37	09 65 462 781 .		09 65 462 681 .		
	Female connector metal shell		2.84 mm pitch		2.84 mm pitch	
		9	09 66 153 761 . 1)		09 66 153 661 . 1)	
		15	09 66 253 761 . 1)		09 66 253 661 . 1)	
		25	09 66 353 761 . 1)		09 66 353 661 . 1)	
37		09 66 453 761 . 1)		09 66 453 661 . 1)		
50		09 66 553 761 . 1)		09 66 553 661 . 1)		
		2.54 mm pitch		2.54 mm pitch		
9		09 66 152 761 .		09 66 152 661 .		
15		09 66 252 761 .		09 66 252 661 .		
25		09 66 352 761 .		09 66 352 661 .		
37		09 66 452 761 .		09 66 452 661 .		
50		09 66 552 761 . 1)		09 66 552 661 . 1)		
Please insert digit for flange thread or fitted female screw locks						
Ø 3.1 mm hole ▶ 0 ¹⁾ M3 ▶ 1 4-40 UNC ▶ 2 fitted screw locks 4-40 UNC ▶ 3						

¹⁾ Not normally kept in stock

Number of contacts

Mounting height

9-37
50

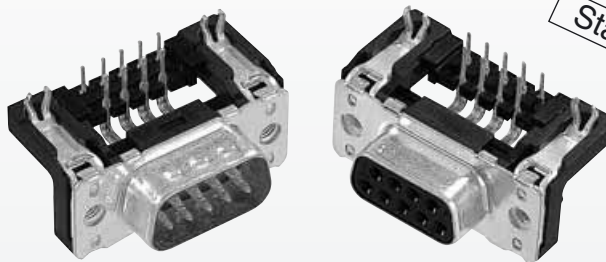
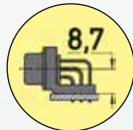

Standard Versions

Stamped solder pins, angled with grounding board locks

Identification

Drawing

Dimensions in mm

Male connector

Mating face acc. to: DIN 41 652 · CECC 75 301-802
IEC 60 807

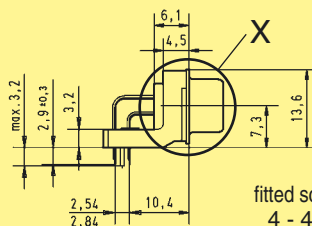
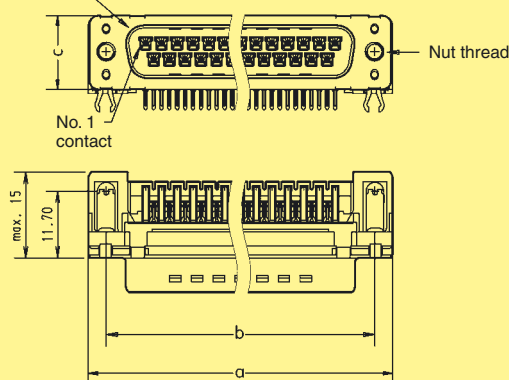

fitted screw locks
4 - 40 UNC

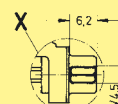

M 3 or
4 - 40 UNC

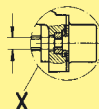

Female connector

9-37 50

Mating face acc. to: DIN 41 652 · CECC 75 301-802
IEC 60 807

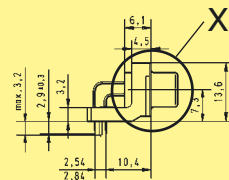
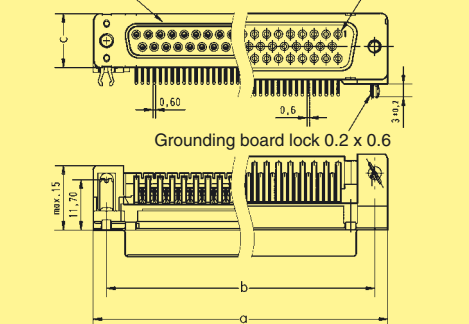

9-37

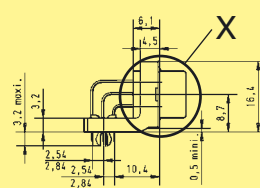

50

Board drillings

9-37 50

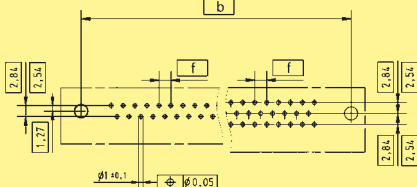

	a	b ± 0.1	c	f
9	30.90	25.00	12.50	2.74
15	39.20	33.30	12.50	2.74
25	53.10	47.00	12.50	2.76
37	69.40	63.50	12.50	2.76
50	67.00	61.10	15.40	2.76

D-Sub - S