



## High-Performance 8-Bit Microcontrollers

# Z8 Encore!<sup>®</sup> 4K Series

### Product Brief

PB014207-0107



## Product Block Diagram

1–4 KB Flash	256 B–1 KB RAM	Up to 8 10-Bit ADC Channels
Watchdog Timer with RC Oscillator	<b>5 MHz eZ8 CPU</b>	Two 16-Bit Timers/PWM
Analog Comparator		POR/VBO & Reset Control
UART with IrDA	On-Chip Debugger	Internal Precision Oscillator
Up to 24 General-Purpose I/O Pins		

## Overview

ZiLOG's Z8 Encore!<sup>®</sup> 4K Series Flash microcontrollers are based on ZiLOG's eZ8 CPU. The Z8 Encore! 4K Series MCU family of devices set a new standard of performance and on-chip peripherals.

The Z8 Encore! 4K Series support up to 4 KB of Flash program memory and 1 KB register RAM.

The Z8 Encore! 4K Series devices feature up to eight single-ended/differential channels of 10-bit A/D conversion. These devices include two enhanced 16-bit reloadable timers featuring Capture, Compare, and PWM capabilities.

Up to 18 vectored interrupts with programmable priorities provide increased application flexibility. An on-chip Internal Precision Oscillator (5.5296 MHz/32.768 kHz) as a trimmable clock source that requires no external components.

The new single-pin debugger and programming interface simplifies code development and allows for easy in-circuit programming.

The full-duplex UART provides serial communications and IrDA encoding and decoding capability. The UART baud rate generator (BRG) can be configured and used as a basic 16-bit timer.

## Z8 Encore! 4K Series Features

Key features of Z8 Encore! 4K Series MCU include:

- 5 MHz eZ8 CPU core
- Up to 4 KB Flash memory with in-circuit programming capability
- Up to 1 KB register RAM
- Up to 8 channels 10-bit Analog-to-Digital Converter (ADC)
- On-chip Analog Comparator
- Full-duplex 9-bit UART with bus transceiver Driver Enable Control
- The UART baud rate generator can be configured and used as a basic 16-bit timer
- Infrared Data Association (IrDA)-compliant infrared encoder/decoders, integrated with UART
- Two 16-bit timers with capture, compare, and PWM capabilities
- Watchdog Timer (WDT) with internal RC oscillator
- 6 to 26 I/O pins depending upon package
- Direct LED Drive with programmable drive strengths available on some devices



- Up to 18 interrupts with configurable priority
- On-Chip Debugger (OCD)
- Voltage Brownout Protection (VBO)
- Power-on Reset (POR)
- Internal Precision Oscillator (5.5296 MHz/32.768 kHz)
- 2.7 V to 3.6 V operating voltage with 5 V-tolerant inputs
- 8-pin, 20-pin, and 28-pin packages
- 0 °C to +70 °C (standard temperature) and –40 °C to +105 °C (extended temperature) operating ranges

## eZ8 CPU Features

The eZ8 CPU, ZiLOG's latest 8-bit central processing unit, meets the continuing demand for faster and more code-efficient microcontrollers. The eZ8 CPU features include:

- New instructions for improved performance including BIT, BSWAP, BTJ, CPC, LDC, LDCI, LEA, MULT, and SRL
- New instructions support 12-bit linear addressing of the Register File
- Compatible with existing Z8<sup>®</sup> code
- Up to 10 MIPS operation
- C-Compiler friendly
- 2 to 9 clock cycles per instruction

## Z8 Encore! 4K Series Development Kit

The Z8 Encore! 4K Series Development System includes the following:

### Hardware

- Z8 Encore! 4K Series Development Board
- Smart Cable for PC to Z8 Encore! 4K Series Development Board (DB9 to 6-pin male)
- 5 V DC power supply

### Software on CD-ROM

- ZDS II–Z8 Encore! IDE with ANSI C-Compiler
- Sample Code
- Document Browser
- Acrobat Reader<sup>®</sup>

### Documentation

- Quick Start Guide
- Z8 Encore! 4K Series technical documentation (on CD-ROM):
  - Development Kit User Manual
  - ZDS II IDE User Manual
  - eZ8 CPU User Manual
  - Product Specification
  - Product Brief
  - Application Notes

## Architecture

Figure 1 illustrates the Z8 Encore! 4K Series block diagram.

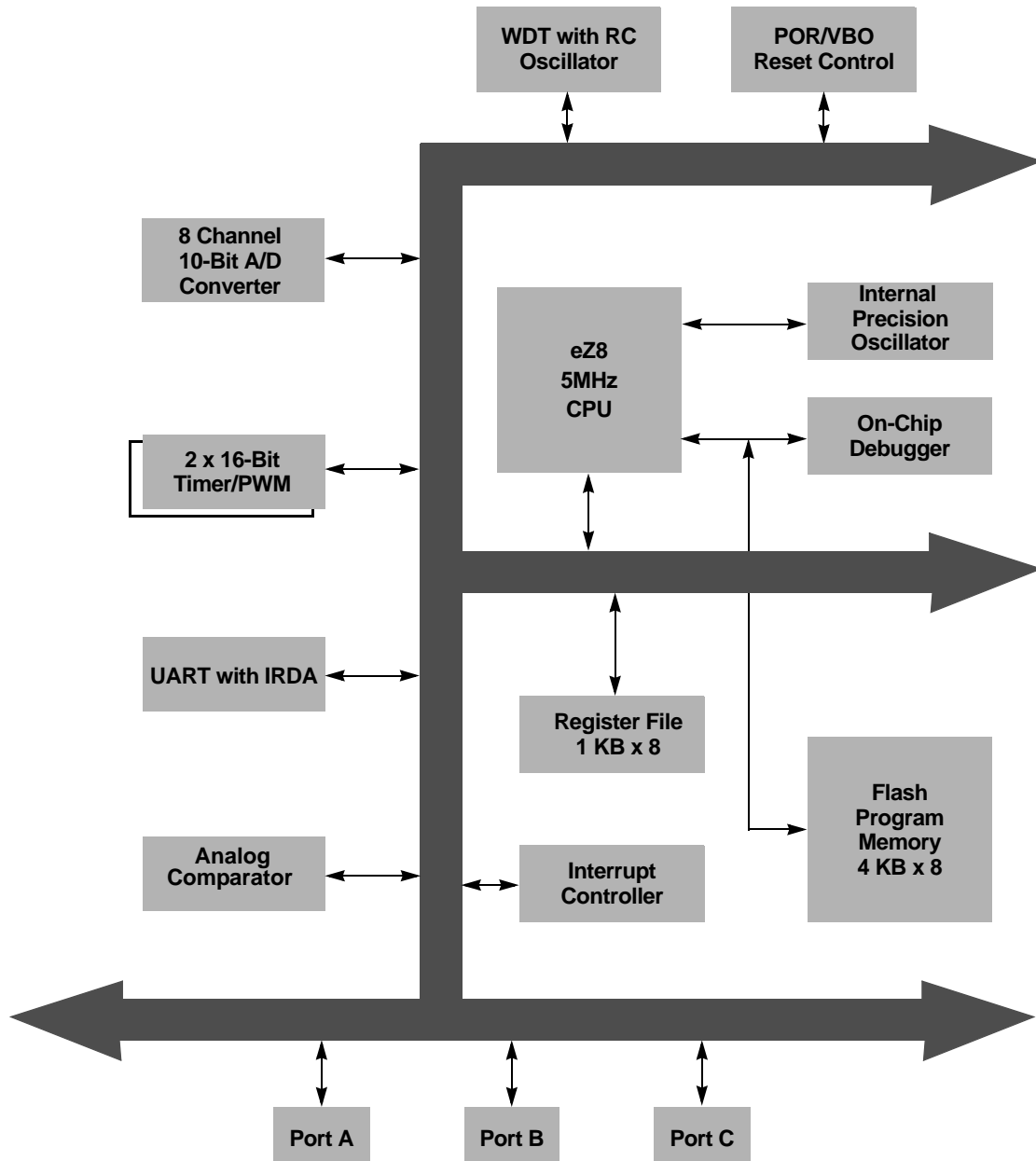

Figure 1. Z8 Encore! 4K Series Block Diagram



## Ordering Information

You can order the Z8 Encore! 4K Series from ZiLOG, using the following part numbers. For more information regarding ordering, contact your local ZiLOG sales office. The ZiLOG website ([www.zilog.com](http://www.zilog.com)) lists all regional offices and provides additional Z8 Encore! product information.

Part Number	Flash	RAM	I/O Lines	Interrupts	16-Bit Timers w/PWM	10-Bit A/D Channels	UART with IrDA	Comparator	Description
<b>Z8 Encore! with 4 KB Flash, 10-Bit Analog-to-Digital Converter</b>									
<b>Standard Temperature: 0 °C to +70 °C</b>									
Z8F0423PB005SC	4 KB	1 KB	6	12	2	4	1	1	PDIP 8-pin package
Z8F0423QB005SC	4 KB	1 KB	6	12	2	4	1	1	QFN 8-pin package
Z8F0423SB005SC	4 KB	1 KB	6	12	2	4	1	1	SOIC 8-pin package
Z8F0423SH005SC	4 KB	1 KB	16	18	2	7	1	1	SOIC 20-pin package
Z8F0423HH005SC	4 KB	1 KB	16	18	2	7	1	1	SSOP 20-pin package
Z8F0423PH005SC	4 KB	1 KB	16	18	2	7	1	1	PDIP 20-pin package
Z8F0423SJ005SC	4 KB	1 KB	22	18	2	8	1	1	SOIC 28-pin package
Z8F0423HJ005SC	4 KB	1 KB	22	18	2	8	1	1	SSOP 28-pin package
Z8F0423PJ005SC	4 KB	1 KB	22	18	2	8	1	1	PDIP 28-pin package
<b>Extended Temperature: -40 °C to +105 °C</b>									
Z8F0423PB005EC	4 KB	1 KB	6	12	2	4	1	1	PDIP 8-pin package
Z8F0423QB005EC	4 KB	1 KB	6	12	2	4	1	1	QFN 8-pin package
Z8F0423SB005EC	4 KB	1 KB	6	12	2	4	1	1	SOIC 8-pin package
Z8F0423SH005EC	4 KB	1 KB	16	18	2	7	1	1	SOIC 20-pin package
Z8F0423HH005EC	4 KB	1 KB	16	18	2	7	1	1	SSOP 20-pin package
Z8F0423PH005EC	4 KB	1 KB	16	18	2	7	1	1	PDIP 20-pin package
Z8F0423SJ005EC	4 KB	1 KB	22	18	2	8	1	1	SOIC 28-pin package
Z8F0423HJ005EC	4 KB	1 KB	22	18	2	8	1	1	SSOP 28-pin package
Z8F0423PJ005EC	4 KB	1 KB	22	18	2	8	1	1	PDIP 28-pin package
<b>Replace C with G for Lead-Free Packaging</b>									



Part Number	Flash	RAM	I/O Lines	Interrupts	16-Bit Timers w/PWM	10-Bit A/D Channels	UART with IrDA	Comparator	Description
<b>Z8 Encore! with 4 KB Flash</b>									
<b>Standard Temperature: 0 °C to +70 °C</b>									
Z8F0413PB005SC	4 KB	1 KB	6	12	2	0	1	1	PDIP 8-pin package
Z8F0413QB005SC	4 KB	1 KB	6	12	2	0	1	1	QFN 8-pin package
Z8F0413SB005SC	4 KB	1 KB	6	12	2	0	1	1	SOIC 8-pin package
Z8F0413SH005SC	4 KB	1 KB	16	18	2	0	1	1	SOIC 20-pin package
Z8F0413HH005SC	4 KB	1 KB	16	18	2	0	1	1	SSOP 20-pin package
Z8F0413PH005SC	4 KB	1 KB	16	18	2	0	1	1	PDIP 20-pin package
Z8F0413SJ005SC	4 KB	1 KB	24	18	2	0	1	1	SOIC 28-pin package
Z8F0413HJ005SC	4 KB	1 KB	24	18	2	0	1	1	SSOP 28-pin package
Z8F0413PJ005SC	4 KB	1 KB	24	18	2	0	1	1	PDIP 28-pin package
<b>Extended Temperature: -40 °C to +105 °C</b>									
Z8F0413PB005EC	4 KB	1 KB	6	12	2	0	1	1	PDIP 8-pin package
Z8F0413QB005EC	4 KB	1 KB	6	12	2	0	1	1	QFN 8-pin package
Z8F0413SB005EC	4 KB	1 KB	6	12	2	0	1	1	SOIC 8-pin package
Z8F0413SH005EC	4 KB	1 KB	16	18	2	0	1	1	SOIC 20-pin package
Z8F0413HH005EC	4 KB	1 KB	16	18	2	0	1	1	SSOP 20-pin package
Z8F0413PH005EC	4 KB	1 KB	16	18	2	0	1	1	PDIP 20-pin package
Z8F0413SJ005EC	4 KB	1 KB	24	18	2	0	1	1	SOIC 28-pin package
Z8F0413HJ005EC	4 KB	1 KB	24	18	2	0	1	1	SSOP 28-pin package
Z8F0413PJ005EC	4 KB	1 KB	24	18	2	0	1	1	PDIP 28-pin package
<b>Replace C with G for Lead-Free Packaging</b>									



Part Number	Flash	RAM	I/O Lines	Interrupts	16-Bit Timers w/PWM	10-Bit A/D Channels	UART with IrDA	Comparator	Description
<b>Z8 Encore! with 2 KB Flash, 10-Bit Analog-to-Digital Converter</b>									
<b>Standard Temperature: 0 °C to +70 °C</b>									
Z8F0223PB005SC	2 KB	512 B	6	12	2	4	1	1	PDIP 8-pin package
Z8F0223QB005SC	2 KB	512 B	6	12	2	4	1	1	QFN 8-pin package
Z8F0223SB005SC	2 KB	512 B	6	12	2	4	1	1	SOIC 8-pin package
Z8F0223SH005SC	2 KB	512 B	16	18	2	7	1	1	SOIC 20-pin package
Z8F0223HH005SC	2 KB	512 B	16	18	2	7	1	1	SSOP 20-pin package
Z8F0223PH005SC	2 KB	512 B	16	18	2	7	1	1	PDIP 20-pin package
Z8F0223SJ005SC	2 KB	512 B	22	18	2	8	1	1	SOIC 28-pin package
Z8F0223HJ005SC	2 KB	512 B	22	18	2	8	1	1	SSOP 28-pin package
Z8F0223PJ005SC	2 KB	512 B	22	18	2	8	1	1	PDIP 28-pin package
<b>Extended Temperature: -40 °C to +105 °C</b>									
Z8F0223PB005EC	2 KB	512 B	6	12	2	4	1	1	PDIP 8-pin package
Z8F0223QB005EC	2 KB	512 B	6	12	2	4	1	1	QFN 8-pin package
Z8F0223SB005EC	2 KB	512 B	6	12	2	4	1	1	SOIC 8-pin package
Z8F0223SH005EC	2 KB	512 B	16	18	2	7	1	1	SOIC 20-pin package
Z8F0223HH005EC	2 KB	512 B	16	18	2	7	1	1	SSOP 20-pin package
Z8F0223PH005EC	2 KB	512 B	16	18	2	7	1	1	PDIP 20-pin package
Z8F0223SJ005EC	2 KB	512 B	22	18	2	8	1	1	SOIC 28-pin package
Z8F0223HJ005EC	2 KB	512 B	22	18	2	8	1	1	SSOP 28-pin package
Z8F0223PJ005EC	2 KB	512 B	22	18	2	8	1	1	PDIP 28-pin package
<b>Replace C with G for Lead-Free Packaging</b>									



Part Number	Flash	RAM	I/O Lines	Interrupts	16-Bit Timers w/PWM	10-Bit A/D Channels	UART with IrDA	Comparator	Description
<b>Z8 Encore! with 2 KB Flash</b>									
<b>Standard Temperature: 0 °C to +70 °C</b>									
Z8F0213PB005SC	2 KB	512 B	6	12	2	0	1	1	PDIP 8-pin package
Z8F0213QB005SC	2 KB	512 B	6	12	2	0	1	1	QFN 8-pin package
Z8F0213SB005SC	2 KB	512 B	6	12	2	0	1	1	SOIC 8-pin package
Z8F0213SH005SC	2 KB	512 B	16	18	2	0	1	1	SOIC 20-pin package
Z8F0213HH005SC	2 KB	512 B	16	18	2	0	1	1	SSOP 20-pin package
Z8F0213PH005SC	2 KB	512 B	16	18	2	0	1	1	PDIP 20-pin package
Z8F0213SJ005SC	2 KB	512 B	24	18	2	0	1	1	SOIC 28-pin package
Z8F0213HJ005SC	2 KB	512 B	24	18	2	0	1	1	SSOP 28-pin package
Z8F0213PJ005SC	2 KB	512 B	24	18	2	0	1	1	PDIP 28-pin package
<b>Extended Temperature: -40 °C to +105 °C</b>									
Z8F0213PB005EC	2 KB	512 B	6	12	2	0	1	1	PDIP 8-pin package
Z8F0213QB005EC	2 KB	512 B	6	12	2	0	1	1	QFN 8-pin package
Z8F0213SB005EC	2 KB	512 B	6	12	2	0	1	1	SOIC 8-pin package
Z8F0213SH005EC	2 KB	512 B	16	18	2	0	1	1	SOIC 20-pin package
Z8F0213HH005EC	2 KB	512 B	16	18	2	0	1	1	SSOP 20-pin package
Z8F0213PH005EC	2 KB	512 B	16	18	2	0	1	1	PDIP 20-pin package
Z8F0213SJ005EC	2 KB	512 B	24	18	2	0	1	1	SOIC 28-pin package
Z8F0213HJ005EC	2 KB	512 B	24	18	2	0	1	1	SSOP 28-pin package
Z8F0213PJ005EC	2 KB	512 B	24	18	2	0	1	1	PDIP 28-pin package
<b>Replace C with G for Lead-Free Packaging</b>									



Part Number	Flash	RAM	I/O Lines	Interrupts	16-Bit Timers w/PWM	10-Bit A/D Channels	UART with IrDA	Comparator	Description
<b>Z8 Encore! with 1 KB Flash, 10-Bit Analog-to-Digital Converter</b>									
<b>Standard Temperature: 0 °C to +70 °C</b>									
Z8F0123PB005SC	1 KB	256 B	6	12	2	4	1	1	PDIP 8-pin package
Z8F0123QB005SC	1 KB	256 B	6	12	2	4	1	1	QFN 8-pin package
Z8F0123SB005SC	1 KB	256 B	6	12	2	4	1	1	SOIC 8-pin package
Z8F0123SH005SC	1 KB	256 B	16	18	2	7	1	1	SOIC 20-pin package
Z8F0123HH005SC	1 KB	256 B	16	18	2	7	1	1	SSOP 20-pin package
Z8F0123PH005SC	1 KB	256 B	16	18	2	7	1	1	PDIP 20-pin package
Z8F0123SJ005SC	1 KB	256 B	22	18	2	8	1	1	SOIC 28-pin package
Z8F0123HJ005SC	1 KB	256 B	22	18	2	8	1	1	SSOP 28-pin package
Z8F0123PJ005SC	1 KB	256 B	22	18	2	8	1	1	PDIP 28-pin package
<b>Extended Temperature: -40 °C to +105 °C</b>									
Z8F0123PB005EC	1 KB	256 B	6	12	2	4	1	1	PDIP 8-pin package
Z8F0123QB005EC	1 KB	256 B	6	12	2	4	1	1	QFN 8-pin package
Z8F0123SB005EC	1 KB	256 B	6	12	2	4	1	1	SOIC 8-pin package
Z8F0123SH005EC	1 KB	256 B	16	18	2	7	1	1	SOIC 20-pin package
Z8F0123HH005EC	1 KB	256 B	16	18	2	7	1	1	SSOP 20-pin package
Z8F0123PH005EC	1 KB	256 B	16	18	2	7	1	1	PDIP 20-pin package
Z8F0123SJ005EC	1 KB	256 B	22	18	2	8	1	1	SOIC 28-pin package
Z8F0123HJ005EC	1 KB	256 B	22	18	2	8	1	1	SSOP 28-pin package
Z8F0123PJ005EC	1 KB	256 B	22	18	2	8	1	1	PDIP 28-pin package
<b>Replace C with G for Lead-Free Packaging</b>									





Part Number	Flash	RAM	I/O Lines	Interrupts	16-Bit Timers w/PWM	10-Bit A/D Channels	UART with IrDA	Comparator	Description
<b>Z8 Encore! with 1 KB Flash</b>									
<b>Standard Temperature: 0 °C to +70 °C</b>									
Z8F0113PB005SC	1 KB	256 B	6	12	2	0	1	1	PDIP 8-pin package
Z8F0113QB005SC	1 KB	256 B	6	12	2	0	1	1	QFN 8-pin package
Z8F0113SB005SC	1 KB	256 B	6	12	2	0	1	1	SOIC 8-pin package
Z8F0113SH005SC	1 KB	256 B	16	18	2	0	1	1	SOIC 20-pin package
Z8F0113HH005SC	1 KB	256 B	16	18	2	0	1	1	SSOP 20-pin package
Z8F0113PH005SC	1 KB	256 B	16	18	2	0	1	1	PDIP 20-pin package
Z8F0113SJ005SC	1 KB	256 B	24	18	2	0	1	1	SOIC 28-pin package
Z8F0113HJ005SC	1 KB	256 B	24	18	2	0	1	1	SSOP 28-pin package
Z8F0113PJ005SC	1 KB	256 B	24	18	2	0	1	1	PDIP 28-pin package
<b>Extended Temperature: -40 °C to +105 °C</b>									
Z8F0113PB005EC	1 KB	256 B	6	12	2	0	1	1	PDIP 8-pin package
Z8F0113QB005EC	1 KB	256 B	6	12	2	0	1	1	QFN 8-pin package
Z8F0113SB005EC	1 KB	256 B	6	12	2	0	1	1	SOIC 8-pin package
Z8F0113SH005EC	1 KB	256 B	16	18	2	0	1	1	SOIC 20-pin package
Z8F0113HH005EC	1 KB	256 B	16	18	2	0	1	1	SSOP 20-pin package
Z8F0113PH005EC	1 KB	256 B	16	18	2	0	1	1	PDIP 20-pin package
Z8F0113SJ005EC	1 KB	256 B	24	18	2	0	1	1	SOIC 28-pin package
Z8F0113HJ005EC	1 KB	256 B	24	18	2	0	1	1	SSOP 28-pin package
Z8F0113PJ005EC	1 KB	256 B	24	18	2	0	1	1	PDIP 28-pin package
<b>Replace C with G for Lead-Free Packaging</b>									
Z8F04A28100KITG									20-Pin and 28-Pin Development Kit
Z8F04A08100KITG									8-Pin Development Kit
ZUSBSC00100ZACG									USB Smart Cable Accessory Kit
ZUSBOPTSC01ZACG									Opto-Isolated USB Smart Cable Accessory Kit



## Part Number Suffix Designations

Z8 F 04 23 S H 005 S C

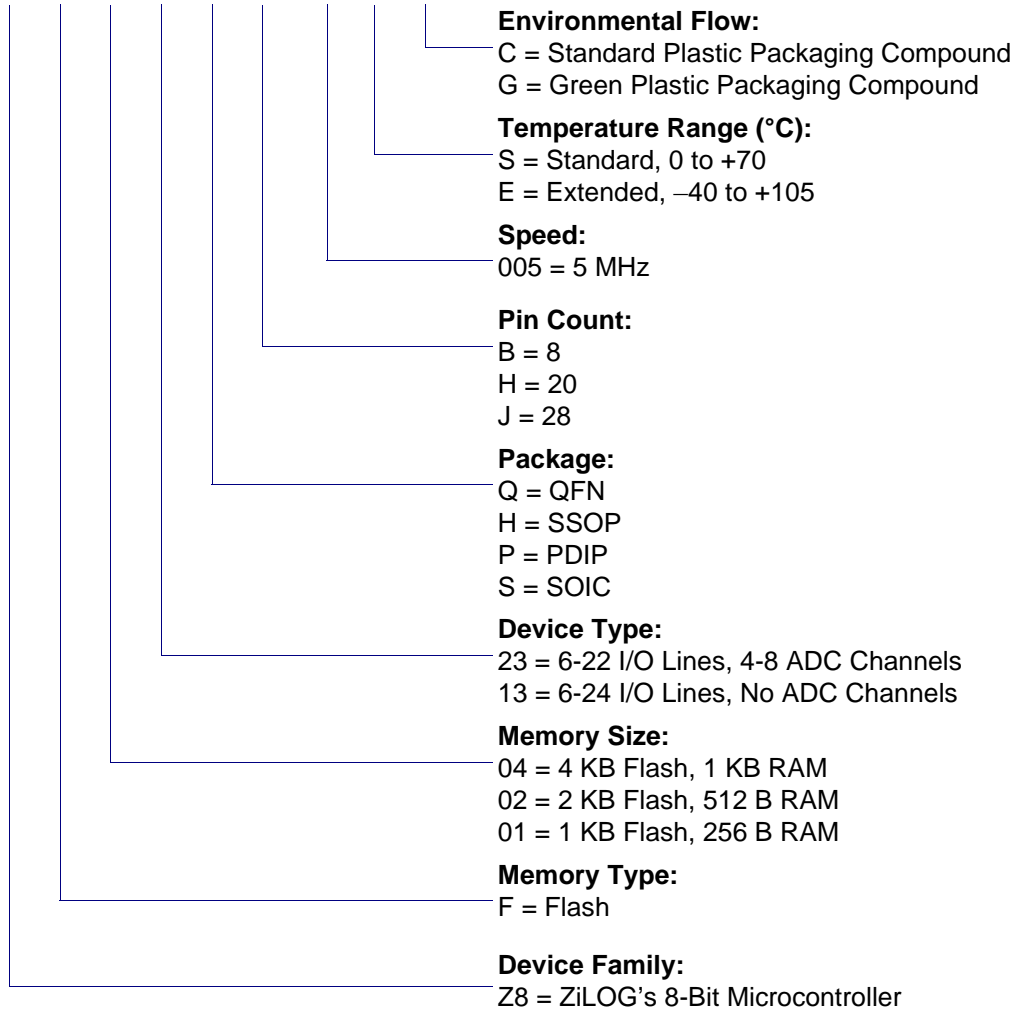



The product brief provides an overview of the silicon feature set and operating parameters and should not be considered as the final specification. See the product specification for the actual feature set and operating parameters for this product.

This publication is subject to replacement by a later edition. To determine whether a later edition exists, or to request copies of publications, visit [www.zilog.com](http://www.zilog.com).

## Feedback

For any comments, detail technical questions, or reporting problems, please visit ZiLOG's Technical Support at <http://support.zilog.com>.

## Document Disclaimer

©2007 by ZiLOG, Inc. All rights reserved. Information in this publication concerning the devices, applications, or technology described is intended to suggest possible uses and may be superseded. ZiLOG, INC. DOES NOT ASSUME LIABILITY FOR OR PROVIDE A REPRESENTATION OF ACCURACY OF THE INFORMATION, DEVICES, OR TECHNOLOGY DESCRIBED IN THIS DOCUMENT. ZiLOG ALSO DOES NOT ASSUME LIABILITY FOR INTELLECTUAL PROPERTY INFRINGEMENT RELATED IN ANY MANNER TO USE OF INFORMATION, DEVICES, OR TECHNOLOGY DESCRIBED HEREIN OR OTHERWISE. Except with the express written approval ZiLOG, use of information, devices, or technology as critical components of life support systems is not authorized. No licenses or other rights are conveyed, implicitly or otherwise, by this document under any intellectual property rights.

ZiLOG is a registered trademark of ZiLOG Inc. in the United States and in other countries. Z8 Encore!, Z8 Encore! XP, and Z8 are registered trademarks of ZiLOG Inc. All other products and/or service names mentioned herein may be trademarks of the companies with which they are associated.