



Actual size:
4.6 x 2.2 x 0.5 in
117 x 56 x 12,7 mm

Maxi Family 28 V Wide Input



DC-DC Converter Module

Features

- DC input range: 9 – 36 V*
- Isolated output
- Input surge withstand: 50 V for 100 ms
- DC output: 3.3 – 48 V
- Programmable output: 10 to 110%
- Regulation: $\pm 0.2\%$ no load to full load
- Efficiency: Up to 85%
- Maximum operating temp: 100°C
- Power density: up to 40 W per cubic inch
- Height above board: 0.43 in. (10,9 mm)
- Parallelable, with N+M fault tolerance
- Low noise ZCS/ZVS architecture
- RoHS Compliant (with F or G pin option)

Product Overview

These DC-DC converter modules use advanced power processing, control and packaging technologies to provide the performance, flexibility, reliability and cost effectiveness of a mature power component. High frequency ZCS/ZVS switching provides high power density with low noise and high efficiency.

Absolute Maximum Ratings

Parameter	Rating	Unit	Notes
+In to -In voltage	-0.5 to +53	Vdc	
PC to -In voltage	-0.5 to +7.0	Vdc	
PR to -In voltage	-0.5 to +7.0	Vdc	
SC to -Out voltage	-0.5 to +1.5	Vdc	
-Sense to -Out voltage	1.0	Vdc	
+Out to -Out, +Sense to -Out			See Module Output Specifications
Isolation voltage			
in to out	3000	Vrms	Test voltage
in to base	1500	Vrms	Test voltage
out to base	500	Vrms	Test voltage
Operating Temperature	-55 to +100	°C	M-Grade
Storage Temperature	-65 to +125	°C	M-Grade
Pin soldering temperature	500 (260)	°F (°C)	<5 sec; wave solder
	750 (390)	°F (°C)	<7 sec; hand solder
Mounting torque	5 (0.57)	in-lbs (N-m)	6 each

Applications

Industrial and process control, distributed power, medical, ATE, communications, defense, aerospace.

*10-36 V DC input range for 3.3, 6.5, 8, 36 and 48 V outputs. All others derate power to 75% for $V_{in} 9 - 10$ V.

For details on proper operation please refer to the [Design Guide & Applications Manual for Maxi, Mini, Micro Family](#).

Part Numbering

e.g. V28A12T200BL2

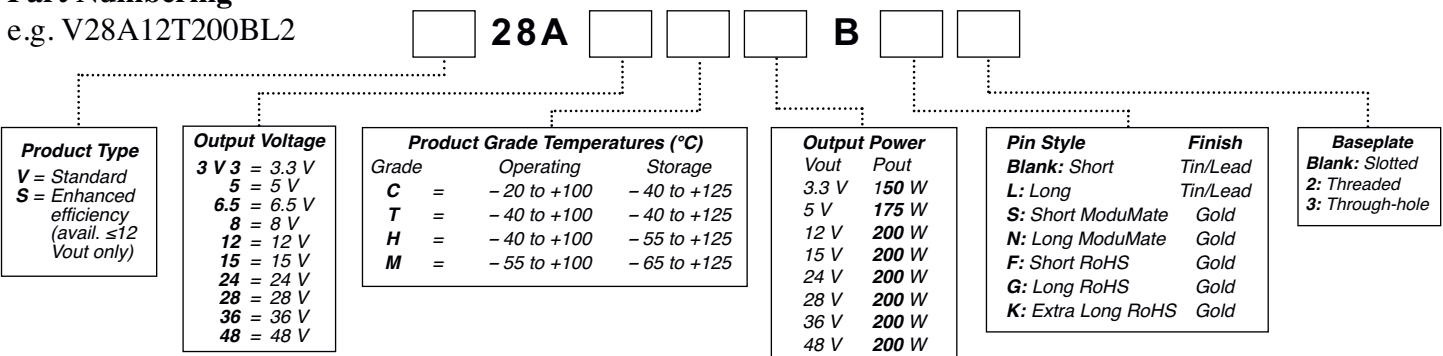

MODULE FAMILY ELECTRICAL CHARACTERISTICS

Electrical characteristics apply over the full operating range of input voltage, output load (resistive) and baseplate temperature, unless otherwise specified. All temperatures refer to the operating temperature at the center of the baseplate.

MODULE INPUT SPECIFICATIONS

Parameter	Min	Typ	Max	Unit	Notes
Operating input voltage	9	28	36	Vdc	
Input surge withstand			50	Vdc	<100 ms
Undervoltage turn-on		8.75	8.9	Vdc	
Undervoltage turn-off	7.8	8.1	8.4	Vdc	
Overvoltage turn-off/on	36.3	37.8	39.6	Vdc	
Disabled input current		12	14	mA	PC pin low

MODULE OUTPUT SPECIFICATIONS

Parameter	Min	Typ	Max	Unit	Notes
Output voltage set point			±1%	Vout nom	Nominal input; full load; 25°C
Line regulation		±0.02	±0.20	%	Low line to high line; full load
Temperature regulation		±0.002	±0.005	% / °C	Over operating temperature range
Power sharing accuracy		±2	±5	%	10 to 100% of full load
Programming range	10		110	%	Of nominal output voltage. For trimming below 90% of nominal, a minimum load of 10% of maximum rated power may be required.
+Out to -Out, +Sense to -Out – Absolute Maximum Ratings					
3.3 V			-0.5 to 4.7	Vdc	Externally Applied
5 V			-0.5 to 7.0	Vdc	Externally Applied
6.5 V			-0.5 to 9.0	Vdc	Externally Applied
8 V			-0.5 to 10.9	Vdc	Externally Applied
12 V			-0.5 to 16.1	Vdc	Externally Applied
15 V			-0.5 to 20.0	Vdc	Externally Applied
24 V			-0.5 to 31.7	Vdc	Externally Applied
28 V			-0.5 to 36.9	Vdc	Externally Applied
36 V			-0.5 to 47.2	Vdc	Externally Applied
48 V			-0.5 to 62.9	Vdc	Externally Applied

THERMAL RESISTANCE AND CAPACITY

Parameter	Min	Typ	Max	Unit
Baseplate to sink; flat, greased surface		0.08		°C/Watt
Baseplate to sink; thermal pad (P/N 20263)		0.07		°C/Watt
Baseplate to ambient		4.9		°C/Watt
Baseplate to ambient; 1000 LFM		1.1		°C/Watt
Thermal capacity		165		Watt-sec/°C

■ MODULE CONTROL SPECIFICATIONS

Parameter	Min	Typ	Max	Unit	Notes
PRIMARY SIDE (PC = Primary Control; PR = Parallel)					
PC bias voltage	5.50	5.75	6.00	Vdc	PC current = 1.0 mA PC voltage = 5.5 V During normal operation
current limit	1.5	2.1	3.0	mA	
PC module disable	2.3	2.6	2.9	Vdc	Switch must be able to sink ≥ 4 mA. See Fig. 2
PC module enable delay		4	7	ms	
PC module alarm			0.5	Vavg	UV, OV, OT, module fault. See Figs. 3 and 5
PC resistance	0.9	1.0	1.1	M Ω	See Fig. 3, converter off or fault mode
PR emitter amplitude	5.7	5.9	6.1	Volts	PR load $>30 \Omega$, <30 pF
PR emitter current	150			mA	
PR receiver impedance	375	500	625	Ω	25°C
PR receiver threshold	2.4	2.5	2.6	Volts	Minimum pulse width: 20 ns
PR drive capability			12	modules	Without PR buffer amplifier
SECONDARY SIDE (SC = Secondary Control)					
SC bandgap voltage	1.21	1.23	1.25	Vdc	Referenced to –Sense
SC resistance	990	1000	1010	Ω	
SC capacitance		0.033		μ F	
SC module alarm		0		Vdc	With open trim; referenced to –Sense. See Fig. 7

■ MODULE GENERAL SPECIFICATIONS

Parameter	Min	Typ	Max	Unit	Notes
Remote sense (total drop)			0.5	Vdc	0.25 V per leg (sense leads must be connected to respective, output terminals)
Isolation test voltage (in to out)*	3000			Vrms	Complies with reinforced insulation requirements
Isolation test voltage (in to base)*	1500			Vrms	Complies with basic insulation requirements
Isolation test voltage (out to base)*	500			Vrms	Complies with operational insulation requirements
Isolation resistance		10		M Ω	in to out, in to baseplate, out to baseplate
Weight (E, C, T grade)	6.5 (184.3)	7.3 (207.5)	8.1 (230.7)	ounces (grams)	
Weight (H, M grade)	7.4 (209.3)	8.2 (232.5)	9.0 (255.7)	ounces (grams)	
Temperature limiting	100	115		°C	See Figs. 3 and 5. Do not operate converter >100 C.
Agency approvals		cURus, cTÜVus, CE			UL60950-1, EN60950-1, CSA60950-1, IEC60950-1. With appropriate fuse in series with the +Input

* Isolation test voltage, 1 minute or less.

Note:

Specifications are subject to change without notice.

■ MODULE SPECIFIC OPERATING SPECIFICATIONS

3.3 Vout, 150 W (e.g. S28A3V3C150BL, V28A3V3C150BL)

Parameter	Min	Typ	Max	Unit	Notes
Efficiency					
S28A3V3C150BL (enhanced efficiency)	78.5	83.7		%	Nominal input; full load; 25°C
V28A3V3C150BL (standard efficiency)	77.3	78.6			
Ripple and noise		80	100	mV	p-p; Nominal input; full load; 20 MHz bandwidth
Output OVP set point	4.14	4.30	4.46	Volts	25°C; recycle input voltage or PC to restart (>100 ms off)
Dissipation, stand-by		11.4	12.7	Watts	No load
Load regulation		±0.02	±0.2	%	No load to full load; nominal input
Load Current	0		45.45	Amps	
Current limit	46.4	52.3	61.5	Amps	Output voltage 95% of nominal
Short circuit current	31.8	52.3	61.5	Amps	Output voltage <250 mV

5 Vout, 175 W (e.g. S28A5C175BL, V28A5C175BL)

Parameter	Min	Typ	Max	Unit	Notes
Efficiency					
S28A5C175BL (enhanced efficiency)	78.6	82.0		%	Nominal input; full load; 25°C
V28A5C175BL (standard efficiency)	77.0	78.6			
Ripple and noise		280	350	mV	p-p; Nominal input; full load; 20 MHz bandwidth
Output OVP set point	6.03	6.25	6.47	Volts	25°C; recycle input voltage or PC to restart (>100 ms off)
Dissipation, stand-by		14.4	15.5	Watts	No load
Load regulation		±0.02	±0.2	%	No load to full load; nominal input
Load Current	0		35	Amps	
Current limit	35.7	40.3	49.0	Amps	Output voltage 95% of nominal
Short circuit current	24.5	40.3	47.3	Amps	Output voltage <250 mV

6.5 Vout, 200 W (e.g. S28A6V5C200BL, V28A6V5C200BL)

Parameter	Min	Typ	Max	Unit	Notes
Efficiency					
S28A6V5C200BL (enhanced efficiency)	80.0	83.0		%	Nominal input; full load; 25°C
V28A6V5C200BL (standard efficiency)	78.5	79.7			
Ripple and noise		275	344	mV	p-p; Nominal input; full load; 20 MHz bandwidth
Output OVP setpoint	7.7	7.98	8.26	Volts	25°C; recycle input voltage or PC to restart (>100 ms off)
Dissipation, standby		11.6	12.2	Watts	No load
Load regulation		±0.02	±0.2	%	No load to full load; nominal input
Output Current	0		30.77	Amps	
Current limit	31.4	35.4	41.6	Amps	Output voltage 95% of nominal
Short circuit current	21.5	35.4	41.6	Amps	Output voltage <250 mV

8 Vout, 200 W (e.g. S28A8C200BL, V28A8C200BL)

Parameter	Min	Typ	Max	Unit	Notes
Efficiency					
S28A8C200BL (enhanced efficiency)	80.5	83.5		%	Nominal input; full load; 25°C
V28A8C200BL (standard efficiency)	79.5	80.9			
Ripple and noise		325	407	mV	p-p; Nominal input; full load; 20 MHz bandwidth
Output OVP setpoint	9.36	9.7	10.1	Volts	25°C; recycle input voltage or PC to restart (>100 ms off)
Dissipation, standby		15.6	16.5	Watts	No load
Load regulation		±0.02	±0.2	%	No load to full load; nominal input
Output Current	0		25	Amps	
Current limit	25.5	28.8	33.8	Amps	Output voltage 95% of nominal
Short circuit current	17.5	28.8	33.8	Amps	Output voltage <250 mV

■ MODULE SPECIFIC OPERATING SPECIFICATIONS (CONT.)

12 Vout, 200 W (e.g. S28A12C200BL, V28A12C200BL)

Parameter	Min	Typ	Max	Unit	Notes
Efficiency					
S28A12C200BL (enhanced efficiency)	83.5	85.5		%	Nominal input; full load; 25°C
V28A12C200BL (standard efficiency)	81.0	83.0			
Ripple and noise		280	350	mV	p-p; Nominal input; full load; 20 MHz bandwidth
Output OVP set point	13.7	14.3	14.9	Volts	25°C; recycle input voltage or PC to restart (>100 ms off)
Dissipation, stand-by		11.0	12.2	Watts	No load
Load regulation		±0.02	±0.2	%	No load to full load; nominal input
Load Current	0		16.67	Amps	
Current limit	17.0	19.2	22.6	Amps	Output voltage 95% of nominal
Short circuit current	11.6	19.2	22.6	Amps	Output voltage < 250mV

15 Vout, 200 W (e.g. V28A15C200BL)

Parameter	Min	Typ	Max	Unit	Notes
Efficiency	82.2	84.5		%	Nominal input; full load; 25°C
Ripple and noise		220	275	mV	p-p; Nominal input; full load; 20 MHz bandwidth
Output OVP set point	17.1	17.8	18.5	Volts	25°C; recycle input voltage or PC to restart (>100 ms off)
Dissipation, stand-by		12.7	13.7	Watts	No load
Load regulation		±0.02	±0.2	%	No load to full load; nominal input
Load Current	0		13.33	Amps	
Current limit	13.5	15.3	20.6	Amps	Output voltage 95% of nominal
Short circuit current	9.31	15.3	20.6	Amps	Output voltage <250 mV

24 Vout, 200 W (e.g. V28A24C200BL)

Parameter	Min	Typ	Max	Unit	Notes
Efficiency	82.8	86.0		%	Nominal input; full load; 25°C
Ripple and noise		315	394	mV	p-p; Nominal input; full load; 20 MHz bandwidth
Output OVP set point	27.1	28.1	29.1	Volts	25°C; recycle input voltage or PC to restart (>100 ms off)
Dissipation, stand-by		12.3	13.5	Watts	No load
Load regulation		±0.02	±0.2	%	No load to full load; nominal input
Load Current	0		8.33	Amps	
Current limit	8.49	9.6	11.3	Amps	Output voltage 95% of nominal
Short circuit current	5.83	9.6	11.3	Amps	Output voltage <250 mV

■ MODULE SPECIFIC OPERATING SPECIFICATIONS (CONT.)

28 Vout, 200 W (e.g. V28A28C200BL)

Parameter	Min	Typ	Max	Unit	Notes
Efficiency	83.5	85.0		%	Nominal input; full load; 25°C
Ripple and noise		200	250	mV	p-p; Nominal input; full load; 20 MHz bandwidth
Output OVP set point	31.5	32.7	33.9	Volts	25°C; recycle input voltage or PC to restart (>100 ms off)
Dissipation, stand-by		15.5	18.0	Watts	No load
Load regulation		±0.02	±0.2	%	No load to full load; nominal input
Load Current	0		7.14	Amps	
Current limit	7.28	8.2	10.0	Amps	Output voltage 95% of nominal
Short circuit current	4.99	8.2	10.0	Amps	Output voltage <250 mV

36 Vout, 200 W (e.g. V28A36C200BL)

Parameter	Min	Typ	Max	Unit	Notes
Efficiency	80.9	82.6		%	Nominal input; full load; 25°C
Ripple and noise		225	282	mV	p-p; Nominal input; full load; 20 MHz bandwidth
Output OVP set point	40.4	41.9	43.4	Volts	25°C; recycle input voltage or PC to restart (>100 ms off)
Dissipation, stand-by		14.4	16.8	Watts	No load
Load regulation		±0.02	±0.2	%	No load to full load; nominal input
Load Current	0		5.56	Amps	
Current limit	5.67	7.7	8.06	Amps	Output voltage 95% of nominal
Short circuit current	3.89	6.9	7.5	Amps	Output voltage <250 mV

48 Vout, 200 W (e.g. V28A48C200BL)

Parameter	Min	Typ	Max	Unit	Notes
Efficiency	81.8	82.6		%	Nominal input; full load; 25°C
Ripple and noise		360	450	mV	p-p; Nominal input; full load; 20 MHz bandwidth
Output OVP set point	53.7	55.7	57.7	Volts	25°C; recycle input voltage or PC to restart (>100 ms off)
Dissipation, stand-by		15.6	18.3	Watts	No load
Load regulation		±0.02	±0.2	%	No load to full load; nominal input
Load Current	0		4.17	Amps	
Current limit	4.25	4.4	5.84	Amps	Output voltage 95% of nominal
Short circuit current	2.92	4.8	5.43	Amps	Output voltage <250 mV

BASIC MODULE OPERATION

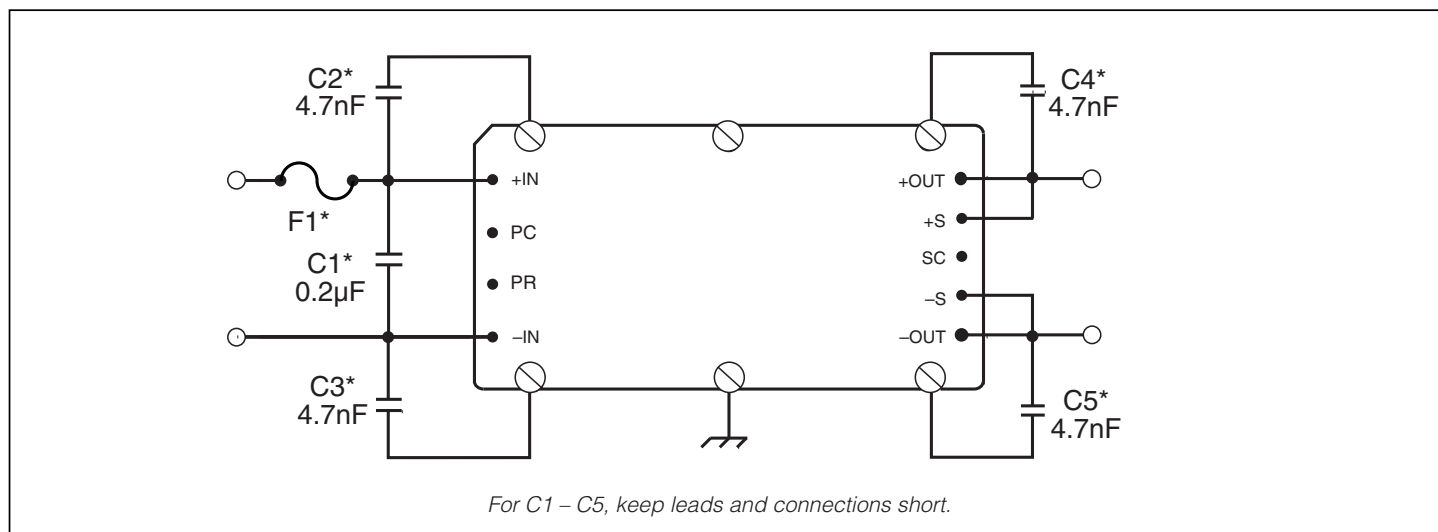

Figure 1 — Basic module operation requires fusing, grounding, bypassing capacitors.

* See Maxi, Mini, Micro Design Guide.

Comprehensive Online Application Information



The Design Guide and Applications Manual includes:

- Application circuits
- Design requirements
- EMC considerations
- Current sharing in power arrays
- Thermal performance information
- Recommended soldering methods
- Accessory modules – filtering, rectification, front-ends
- Mounting options
- ...and more.

[CLICK HERE TO VIEW DESIGN GUIDE](#)

Also at vicorpower.com

- PowerBench online configurators
- Over 20 Application Notes
- Online calculators – thermal, trimming, hold-up
- PDF data sheets for ALL Vicor products

PRIMARY CONTROL - PC PIN

Module Enable / Disable

The module may be disabled by pulling PC below 2.3 V with respect to the -Input. This may be done with an open collector transistor, relay, or optocoupler. Multiple converters may be disabled with a single transistor or relay either directly or via "OR'ing" diodes. See Figure 2.

Primary Auxiliary Supply

At 5.7 V, PC can source up to 1.5 mA. In the example shown in Figure 4, PC powers a module enabled LED.

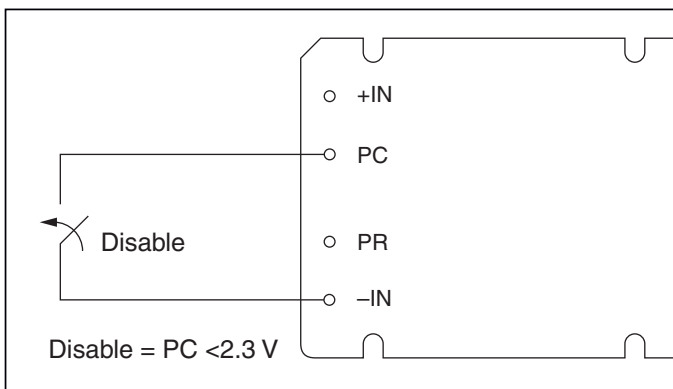

Figure 2 — Module enable / disable.

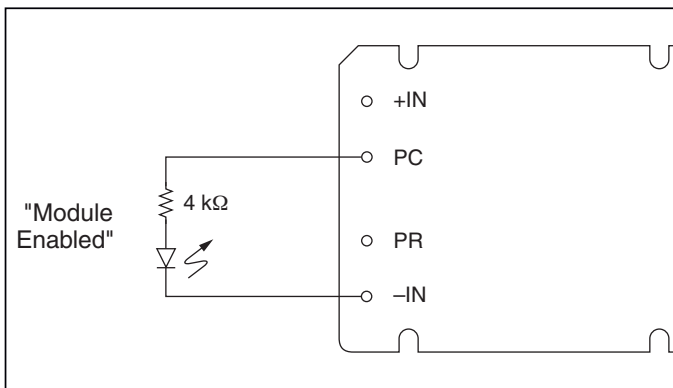

Figure 4 — LED on-state indicator.

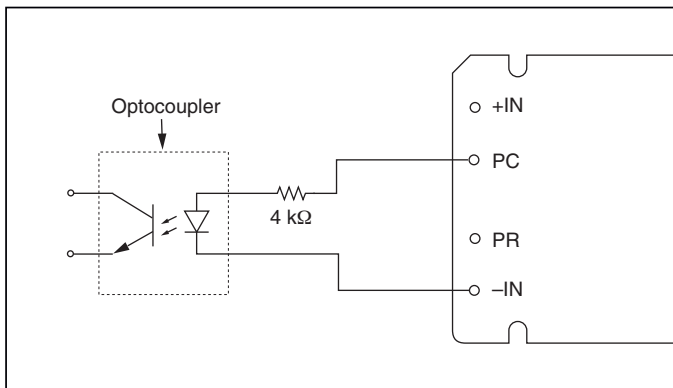

Figure 6 — Isolated on-state indicator.

Module Alarm

The module contains "watchdog" circuitry which monitors input voltage, operating temperature and internal operating parameters. In the event that any of these parameters are outside of their allowable operating range, the module will shut down and PC will go low. PC will periodically go high and the module will check to see if the fault (as an example, overtemperature) has cleared. If the fault has not been cleared, PC will go low again and the cycle will restart. The SC pin will go low in the event of a fault and return to its normal state after the fault has been cleared. See Figures 3 and 5.

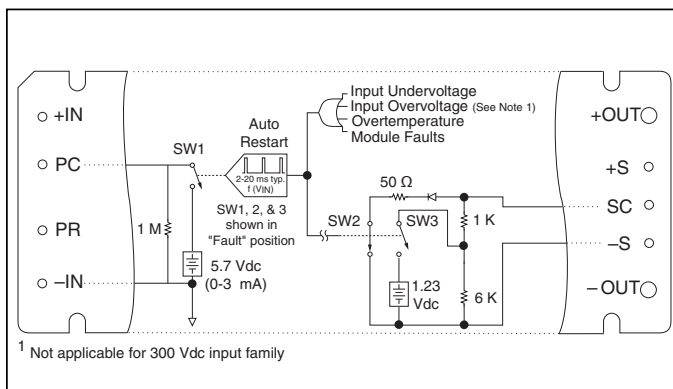

Figure 3 — PC/SC module alarm logic.

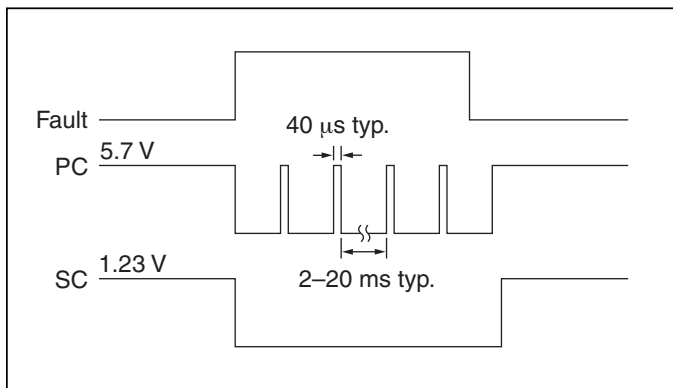

Figure 5 — PC/SC module alarm timing.

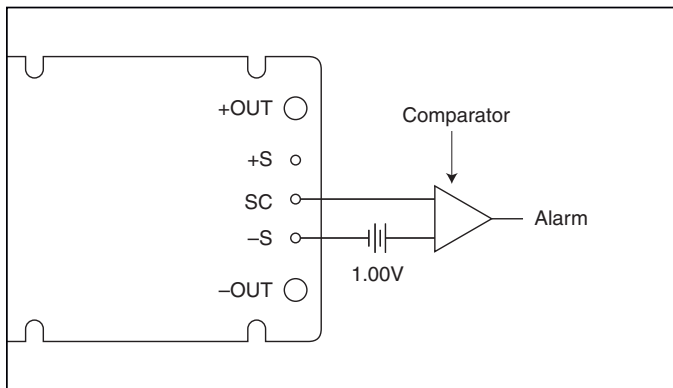

Figure 7 — Secondary side on-state indicator.

SECONDARY CONTROL - SC PIN

Output Voltage Programming

The output voltage of the converter can be adjusted or programmed via fixed resistors, potentiometers or voltage DACs. See Figure 8.

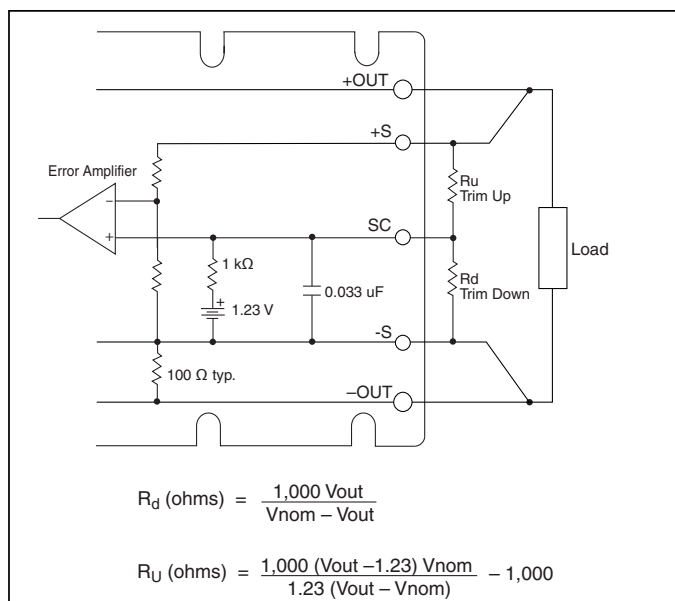

Figure 8 — Output voltage trim down and trim up circuit.

Trim Down

1. This converter is not a constant power device – it has a constant current limit. Hence, available output power is reduced by the same percentage that output voltage is trimmed down. Do not exceed maximum rated output current.
2. The trim down resistor must be connected between the SC and -S pins. Do not bypass the SC pin directly with a capacitor.

Trim Up

1. The converter is rated for a maximum delivered power. To ensure that maximum rated power is not exceeded, reduce maximum output current by the same percentage increase in output voltage.
2. The trim up resistor must be connected between the SC and +S pins. Do not bypass the SC pin directly with a capacitor.
3. Do not trim the converter above maximum trim range (typically +10%) or the output over voltage protection circuitry may be activated.

Trim resistor values calculated automatically:

On-line calculators for trim resistor values are available on the vicor website at:

asp.vicorpower.com/calculators/calculators.asp?calc=1

Resistor values can be calculated for fixed trim up, fixed trim down and for variable trim up or down.

PARALLEL BUS - PR PIN

Parallel Operation

The PR pin supports paralleling for increased power with N+1 (N+M) redundancy. Modules of the same input voltage, output voltage, and power level will current share if all PR pins are suitably interfaced.

Compatible interface architectures include the following:

AC coupled single-wire interface. All PR pins are connected to a single communication bus through 0.001 μF (500 V) capacitors. This interface supports current sharing and is fault tolerant except for the communication bus. Up to three converters may be paralleled by this method. See Figure 9.

Transformer coupled interface. For paralleling four or more converters a transformer coupled interface is required. See Figure 10.

For details on parallel operation please refer to the

[Design Guide & Applications Manual for Maxi, Mini, Micro Family.](#)

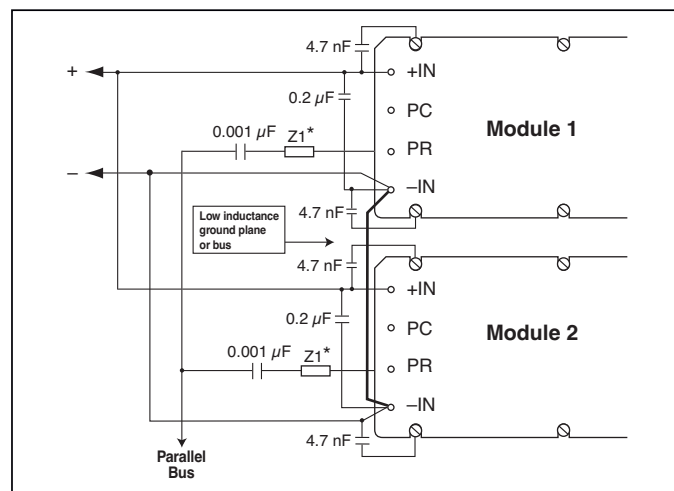

Figure 9 — AC coupled single-wire interface.

* See Maxi, Mini, Micro Design Guide.

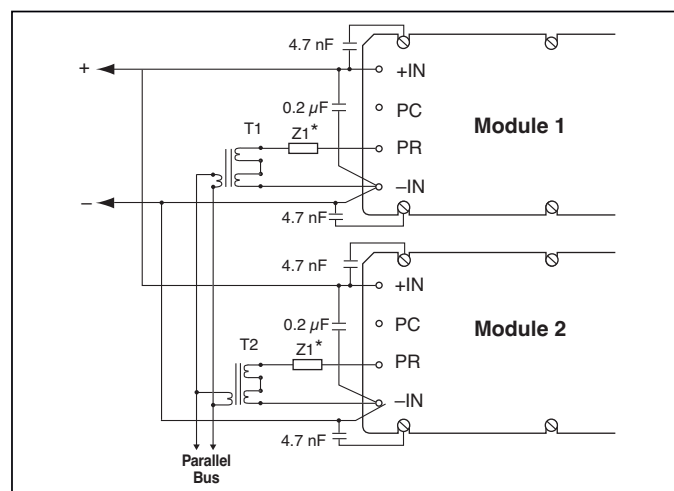

Figure 10 — Transformer-coupled interface.

PARALLEL BUS OUTPUT

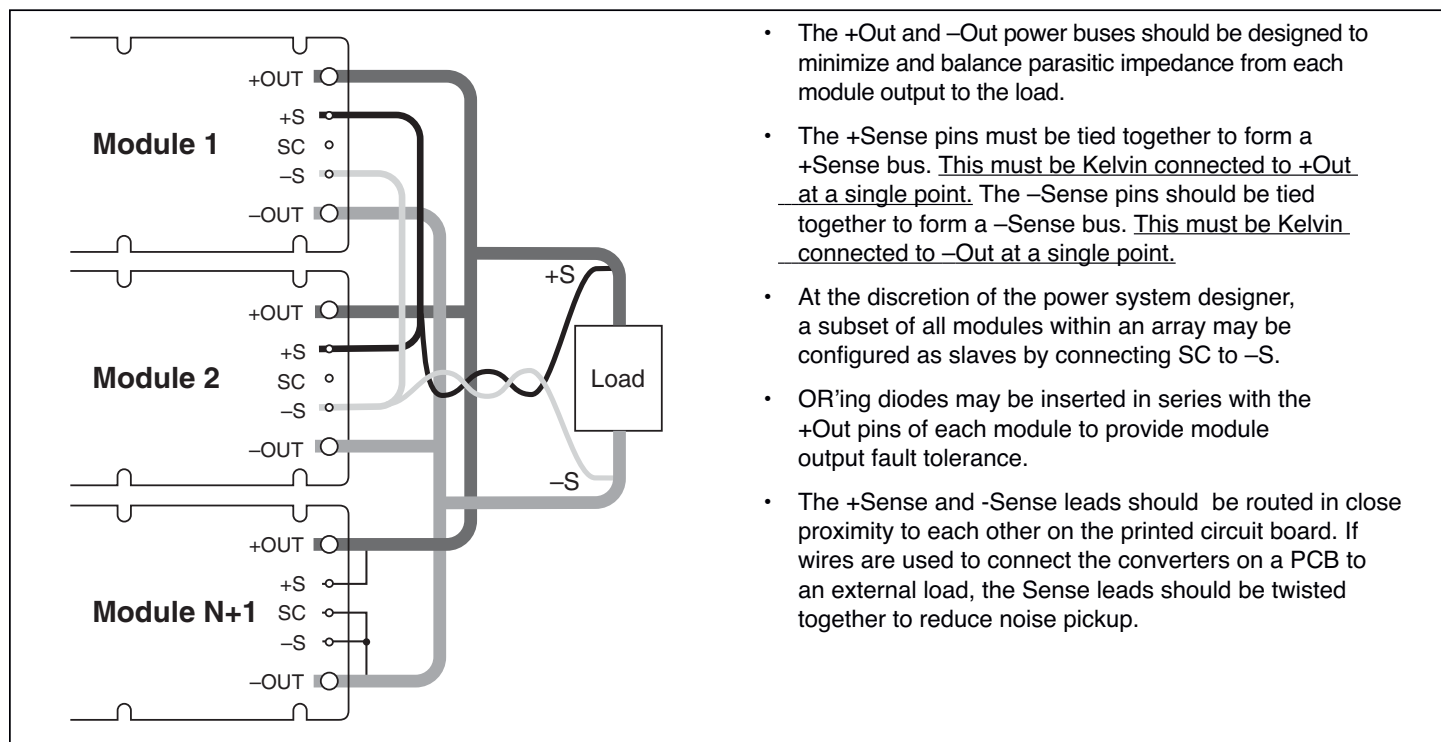

Figure 11 – N+1 module array output connections.

■ PIN STYLES*

Designator	Description	Finish	Notes
(None)	Short	Tin/Lead	Requires in-board, mounting
L	Long	Tin/Lead	On-board mounting for 0.065" boards
S	Short ModuMate	Gold	SurfMate or in-board socket mounting
N	Long ModuMate	Gold	On-board socket mounting
F	Short RoHS	Gold	Select for RoHS compliant in-board solder, socket, or SurfMate mounting
G	Long RoHS	Gold	Select for RoHS compliant on-board solder or socket mounting
K	Extra Long RoHS	Gold	Select for RoHS compliance on-board mounting for thicker PCBs (not intended for socket or Surfmate mounting)

* Pin style designator follows the "B" after the output power and precedes the baseplate designator.
Ex. V48A12T500BN2 – Long ModuMate Pins

MECHANICAL DRAWINGS

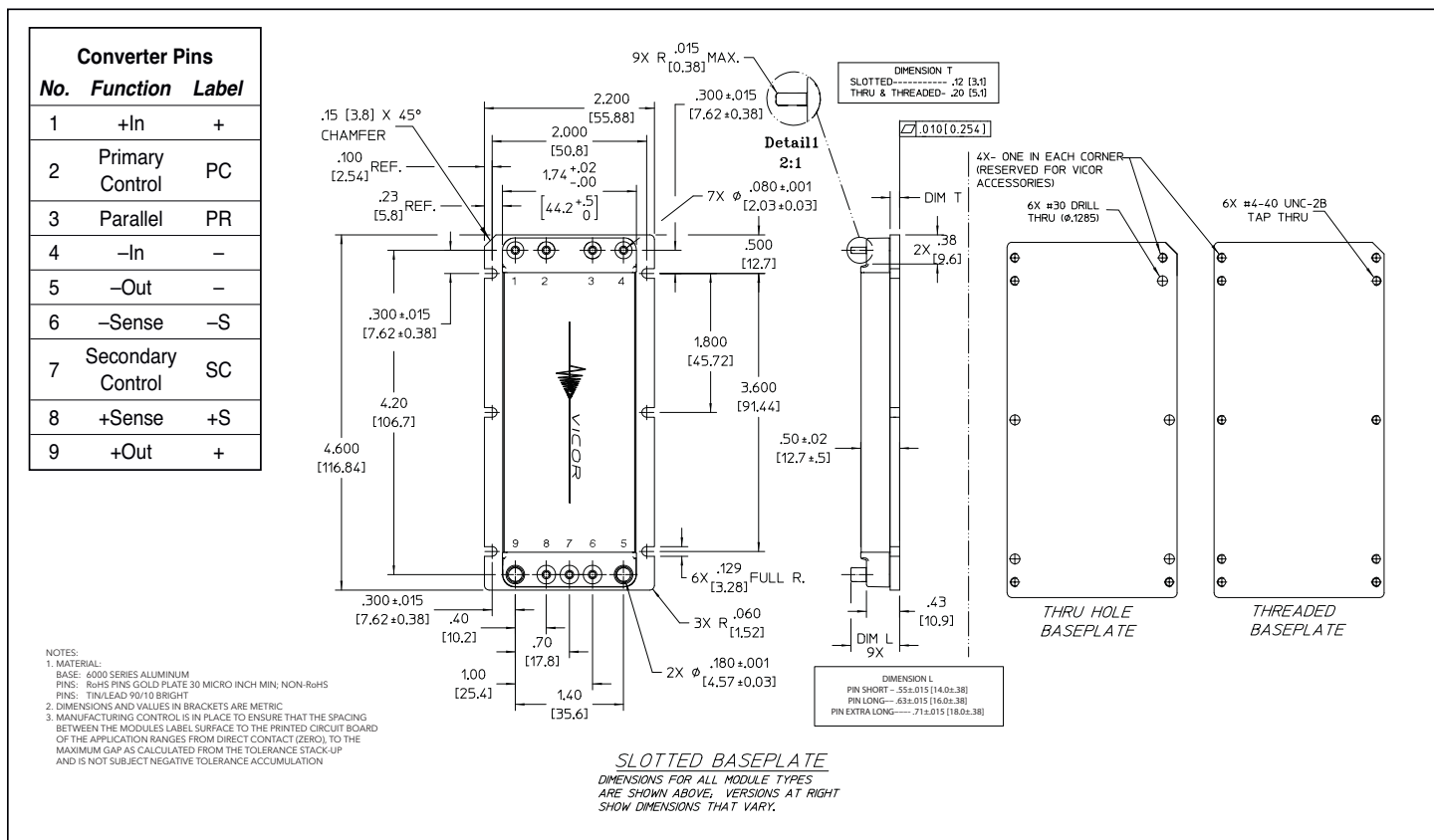

Figure 12 — Module outline

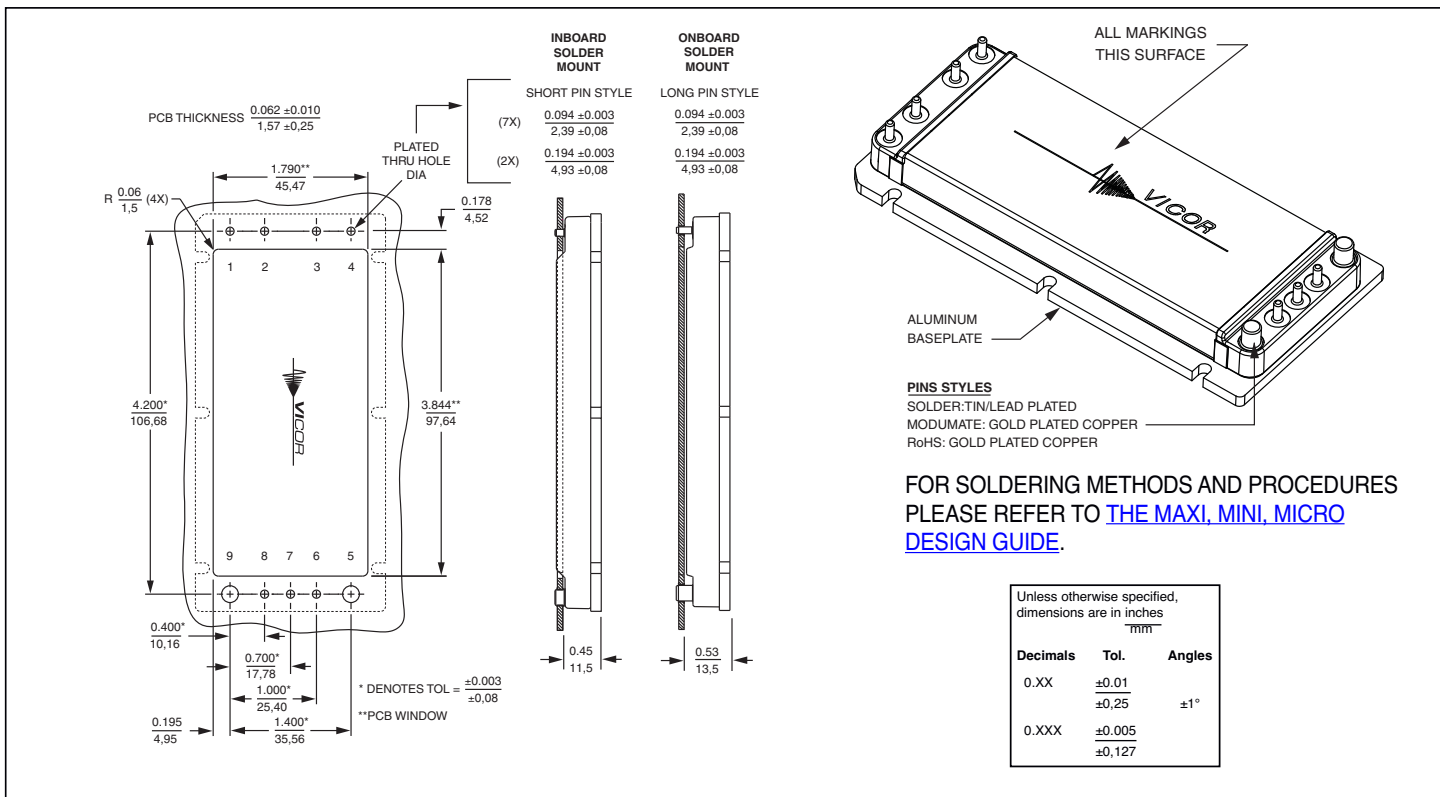

Figure 13 — PCB mounting specifications

Vicor's comprehensive line of power solutions includes high density AC-DC and DC-DC modules and accessory components, fully configurable AC-DC and DC-DC power supplies, and complete custom power systems.

Information furnished by Vicor is believed to be accurate and reliable. However, no responsibility is assumed by Vicor for its use. Vicor makes no representations or warranties with respect to the accuracy or completeness of the contents of this publication. Vicor reserves the right to make changes to any products, specifications, and product descriptions at any time without notice. Information published by Vicor has been checked and is believed to be accurate at the time it was printed; however, Vicor assumes no responsibility for inaccuracies. Testing and other quality controls are used to the extent Vicor deems necessary to support Vicor's product warranty. Except where mandated by government requirements, testing of all parameters of each product is not necessarily performed.

Specifications are subject to change without notice.

Vicor's Standard Terms and Conditions

All sales are subject to Vicor's Standard Terms and Conditions of Sale, which are available on Vicor's webpage or upon request.

Product Warranty

In Vicor's standard terms and conditions of sale, Vicor warrants that its products are free from non-conformity to its Standard Specifications (the "Express Limited Warranty"). This warranty is extended only to the original Buyer for the period expiring two (2) years after the date of shipment and is not transferable.

UNLESS OTHERWISE EXPRESSLY STATED IN A WRITTEN SALES AGREEMENT SIGNED BY A DULY AUTHORIZED VICOR SIGNATORY, VICOR DISCLAIMS ALL REPRESENTATIONS, LIABILITIES, AND WARRANTIES OF ANY KIND (WHETHER ARISING BY IMPLICATION OR BY OPERATION OF LAW) WITH RESPECT TO THE PRODUCTS, INCLUDING, WITHOUT LIMITATION, ANY WARRANTIES OR REPRESENTATIONS AS TO MERCHANTABILITY, FITNESS FOR PARTICULAR PURPOSE, INFRINGEMENT OF ANY PATENT, COPYRIGHT, OR OTHER INTELLECTUAL PROPERTY RIGHT, OR ANY OTHER MATTER.

This warranty does not extend to products subjected to misuse, accident, or improper application, maintenance, or storage. Vicor shall not be liable for collateral or consequential damage. Vicor disclaims any and all liability arising out of the application or use of any product or circuit and assumes no liability for applications assistance or buyer product design. Buyers are responsible for their products and applications using Vicor products and components. Prior to using or distributing any products that include Vicor components, buyers should provide adequate design, testing and operating safeguards.

Vicor will repair or replace defective products in accordance with its own best judgment. For service under this warranty, the buyer must contact Vicor to obtain a Return Material Authorization (RMA) number and shipping instructions. Products returned without prior authorization will be returned to the buyer. The buyer will pay all charges incurred in returning the product to the factory. Vicor will pay all reshipment charges if the product was defective within the terms of this warranty.

Life Support Policy

VICOR'S PRODUCTS ARE NOT AUTHORIZED FOR USE AS CRITICAL COMPONENTS IN LIFE SUPPORT DEVICES OR SYSTEMS WITHOUT THE EXPRESS PRIOR WRITTEN APPROVAL OF THE CHIEF EXECUTIVE OFFICER AND GENERAL COUNSEL OF VICOR CORPORATION. As used herein, life support devices or systems are devices which (a) are intended for surgical implant into the body, or (b) support or sustain life and whose failure to perform when properly used in accordance with instructions for use provided in the labeling can be reasonably expected to result in a significant injury to the user. A critical component is any component in a life support device or system whose failure to perform can be reasonably expected to cause the failure of the life support device or system or to affect its safety or effectiveness. Per Vicor Terms and Conditions of Sale, the user of Vicor products and components in life support applications assumes all risks of such use and indemnifies Vicor against all liability and damages.

Intellectual Property Notice

Vicor and its subsidiaries own Intellectual Property (including issued U.S. and Foreign Patents and pending patent applications) relating to the products described in this data sheet. No license, whether express, implied, or arising by estoppel or otherwise, to any intellectual property rights is granted by this document. Interested parties should contact Vicor's Intellectual Property Department.

Vicor Corporation
25 Frontage Road
Andover, MA, USA 01810
Tel: 800-735-6200
Fax: 978-475-6715

email

Customer Service: custserv@vicorpower.com
Technical Support: apps@vicorpower.com

Mouser Electronics

Authorized Distributor

Click to View Pricing, Inventory, Delivery & Lifecycle Information:

[Vicor:](#)

[V28A28C200BL](#) [V28A24C200BG3](#) [V28A5C175BL](#) [V28A28T200BL](#) [V28A12C200BL](#) [V28A28T200BG](#)
[V28A15C200BL](#) [V28A36C200BL](#) [V28A24C200BL](#) [V28A28H200BL](#) [V28A24C200BL2](#) [V28A28C200BG](#)