



SF21G THRU SF28G

2.0 AMPS. Glass Passivated Super Fast Rectifiers



Voltage Range
50 to 600 Volts
Current
2.0 Amperes

Features

- ✧ Low forward voltage drop
- ✧ High current capability
- ✧ High reliability
- ✧ High surge current capability

Mechanical Data

- ✧ Case: Molded plastic
- ✧ Epoxy: UL 94V-O rate flame retardant
- ✧ Lead: Axial leads, solderable per MIL-STD-202, Method 208 guaranteed
- ✧ Polarity: Color band denotes cathode end
- ✧ High temperature soldering guaranteed: 260°C/10 seconds/.375", (9.5mm) lead lengths at 5 lbs., (2.3kg) tension
- ✧ Mounting position: Any
- ✧ Weight: 0.40 gram

DO-15

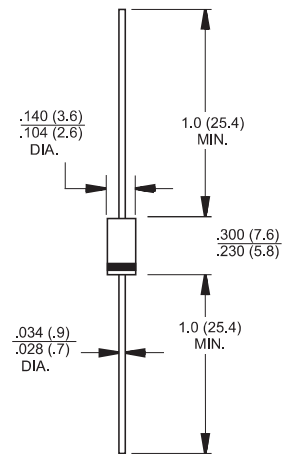

Dimensions in inches and (millimeters)

Maximum Ratings and Electrical Characteristics

Rating at 25°C ambient temperature unless otherwise specified.
Single phase, half wave, 60 Hz, resistive or inductive load.
For capacitive load, derate current by 20%

Type Number	Symbol	SF 21G	SF 22G	SF 23G	SF 24G	SF 25G	SF 26G	SF 27G	SF 28G	Units
Maximum Recurrent Peak Reverse Voltage	V_{RRM}	50	100	150	200	300	400	500	600	V
Maximum RMS Voltage	V_{RMS}	35	70	105	140	210	280	350	420	V
Maximum DC Blocking Voltage	V_{DC}	50	100	150	200	300	400	500	600	V
Maximum Average Forward Rectified Current .375(9.5mm) Lead Length @ $T_A=55^\circ\text{C}$	$I_{(AV)}$	2.0								A
Peak Forward Surge Current, 8.3 ms Single Half Sine-wave Superimposed on Rated Load (JEDEC method)	I_{FSM}	50								A
Maximum Instantaneous Forward Voltage @ 2.0A	V_F	0.95			1.3		1.7			V
Maximum DC Reverse Current @ $T_A=25^\circ\text{C}$ at Rated DC Blocking Voltage @ $T_A=125^\circ\text{C}$	I_R	5.0 100								μA μA
Maximum Reverse Recovery Time (Note 1)	T_{rr}	35								nS
Typical Junction Capacitance (Note 2)	C_j	60				30				pF
Operating Temperature Range	T_J	-65 to +150								$^\circ\text{C}$
Storage Temperature Range	T_{STG}	-65 to +150								$^\circ\text{C}$

Notes: 1. Reverse Recovery Test Conditions: $I_F=0.5\text{A}$, $I_R=1.0\text{A}$, $I_{RR}=0.25\text{A}$
2. Measured at 1 MHz and Applied Reverse Voltage of 4.0 V D.C.

RATINGS AND CHARACTERISTIC CURVES (SF21G THRU SF28G)

FIG.1- REVERSE RECOVERY TIME CHARACTERISTIC AND TEST CIRCUIT DIAGRAM

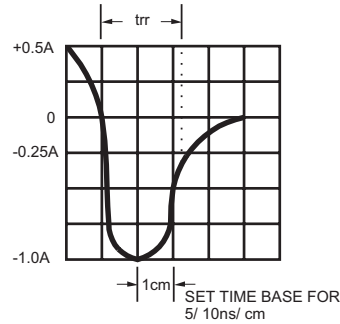
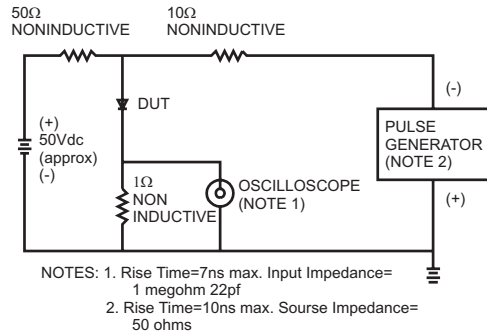

FIG.2- MAXIMUM AVERAGE FORWARD CURRENT DERATING

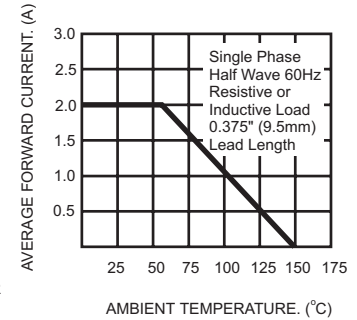

FIG.3- TYPICAL REVERSE CHARACTERISTICS

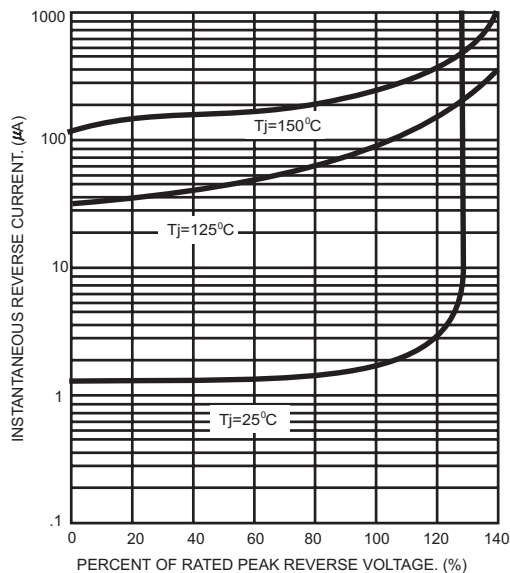

FIG.4- TYPICAL FORWARD CHARACTERISTICS

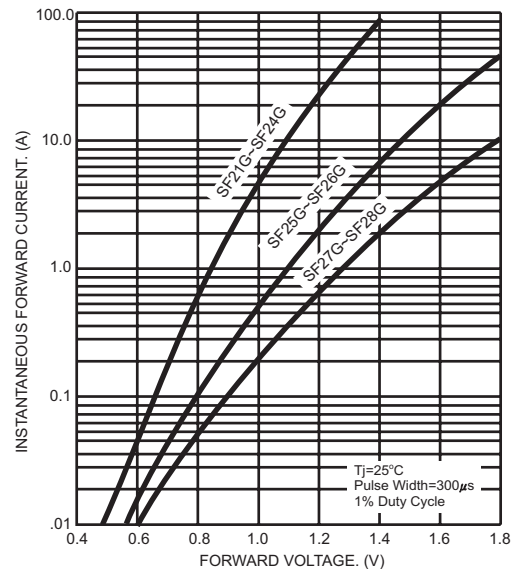

FIG.5- MAXIMUM NON-REPETITIVE FORWARD SURGE CURRENT

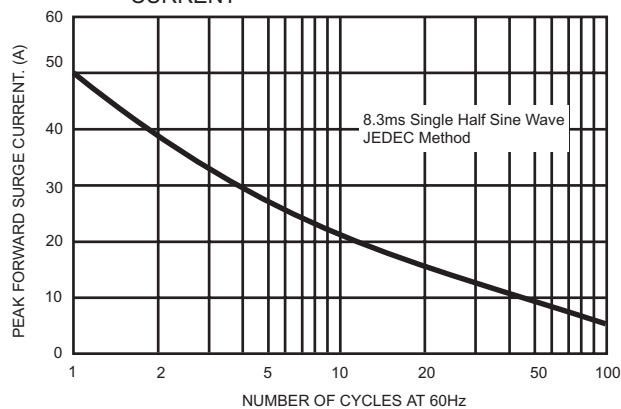

FIG.6- TYPICAL JUNCTION CAPACITANCE

