

Intellimod™ Module Dual-In-Line Intelligent Power Module 15 Amperes/1200 Volts

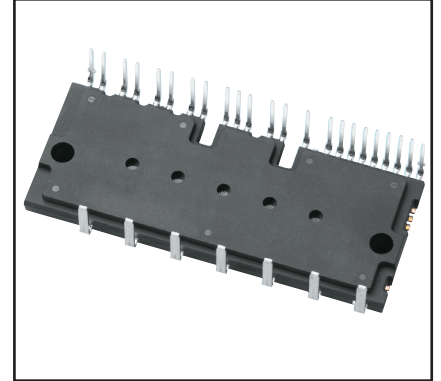
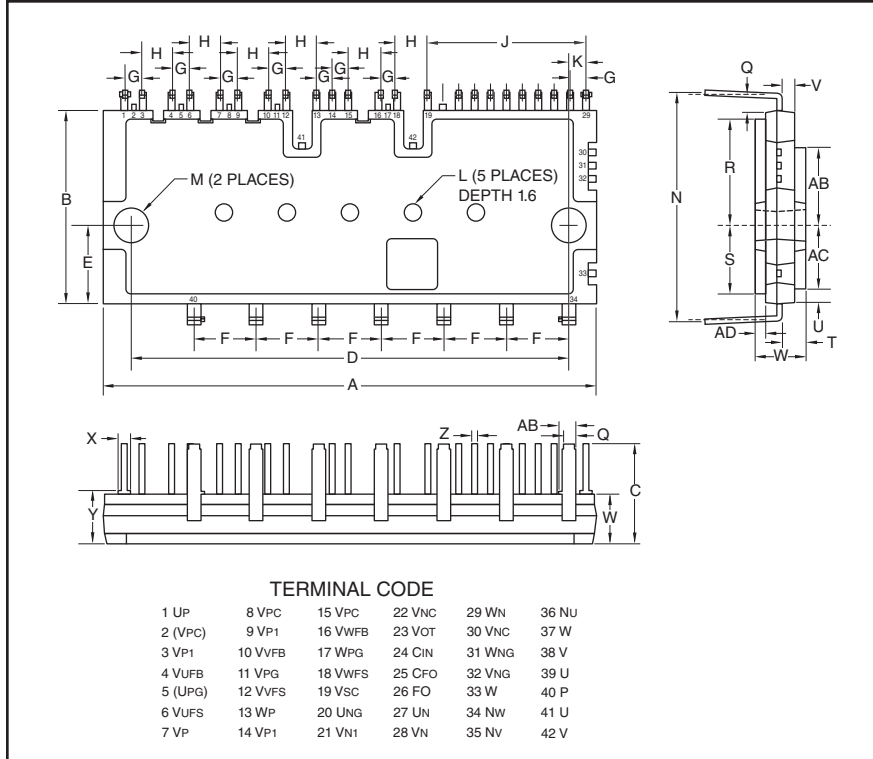

Description:

DIPIMs are intelligent power modules that integrate power devices, drivers, and protection circuitry. Design time is reduced by the use of application-specific HVICs and value-added features such as linear temperature feedback. Overall efficiency and reliability are increased by the use of full gate CSTBT technology and low thermal impedance.

Features:

- Low-loss, Full Gate CSTBT IGBTs
- Single Power Supply
- Integrated HVICs
- Direct Connection to CPU

Applications:

- Variable Speed Pumps
- Variable Speed Compressors
- Small Motor Control

Ordering Information:

PS22A74 is a 1200V, 15 Ampere DIP Intelligent Power Module.

Outline Drawing and Circuit Diagram

| Dimensions | Inches | Millimeters |
|------------|----------------|--------------|
| A | 3.11±0.02 | 79.0±0.5 |
| B | 1.22±0.02 | 31.0±0.5 |
| C | 0.63 | 16.0 |
| D | 2.76±0.01 | 70.0±0.3 |
| E | 0.5 | 12.7 |
| F | 0.39±0.01 | 10.0±0.3 |
| G | 0.1±0.01 | 2.54±0.3 |
| H | 0.2±0.01 | 5.08±0.3 |
| J | 1.0 | 25.4 |
| K | 0.11 | 2.8 |
| L | 0.12 Dia. | 2.9 Dia. |
| M | 0.18±0.01 Dia. | 4.5±0.2 Dia. |
| N | 1.42±0.02 | 36.2±0.5 |
| P | 0.03 | 0.7 |

| Dimensions | Inches | Millimeters |
|------------|-----------|-------------|
| Q | 0.08 | 2.0 |
| R | 0.66 | 16.73 |
| S | 0.44 | 11.13 |
| T | 0.15±0.04 | 3.8±1.0 |
| U | 0.082 | 2.1 |
| V | 0.086 | 2.2 |
| W | 0.31 | 8.0 |
| X | 0.07 | 1.8 |
| Y | 0.34 | 8.6 |
| Z | 0.03 | 0.8 |
| AA | 0.10 | 2.7 |
| AB | 0.48 | 12.33 |
| AC | 0.39 | 10.12 |
| AD | 0.068 | 1.75 |

PS22A74
Intellimod™ Module
Dual-In-Line Intelligent Power Module
 15 Amperes/1200 Volts

Absolute Maximum Ratings, $T_j = 25^\circ\text{C}$ unless otherwise specified

| Characteristics | Symbol | PS22A74 | Units |
|--|------------------------|------------|------------------|
| Self-protection Supply Voltage Limit (Short Circuit Protection Capability)* | $V_{CC(\text{prot.})}$ | 800 | Volts |
| Module Case Operation Temperature (See T_C Measurement Point Below) | T_C | -20 to 100 | $^\circ\text{C}$ |
| Storage Temperature | T_{stg} | -40 to 125 | $^\circ\text{C}$ |
| Mounting Torque, M4 Mounting Screws | — | 13 | in-lb |
| Module Weight (Typical) | — | 65 | Grams |
| Isolation Voltage, AC 1 minute, 60Hz Sinusoidal, Connection Pins to Heatsink Plate | V_{ISO} | 2500 | Volts |

IGBT Inverter Sector

| | | | |
|--|------------------------|------------|------------------|
| Supply Voltage (Applied between P-NU, NV, NW) | V_{CC} | 900 | Volts |
| Supply Voltage, Surge (Applied between P-NU, NV, NW) | $V_{CC(\text{surge})}$ | 1000 | Volts |
| Collector-Emitter Voltage ($T_C = 25^\circ\text{C}$) | V_{CES} | 1200 | Volts |
| Collector Current ($T_C = 25^\circ\text{C}$) | $\pm I_C$ | 15 | Amperes |
| Peak Collector Current ($T_C = 25^\circ\text{C}$, <1ms) | $\pm I_{CP}$ | 30 | Amperes |
| Collector Dissipation ($T_C = 25^\circ\text{C}$, per 1 Chip) | P_C | 86.9 | Watts |
| Power Device Junction Temperature** | T_j | -20 to 150 | $^\circ\text{C}$ |

Control Sector

| | | | |
|---|----------|------------------|-------|
| Supply Voltage (Applied between V_{P+} - V_{PC} , V_{N+} - V_{NC}) | V_D | 20 | Volts |
| Supply Voltage (Applied between V_{UFB} - V_{UFS} , V_{VFB} - V_{VFS} , V_{WFB} - V_{WFS}) | V_{DB} | 20 | Volts |
| Input Voltage (Applied between U_P , V_P , W_P - V_{PC} , U_N , V_N , W_N - V_{NC}) | V_{IN} | -0.5 ~ $V_D+0.5$ | Volts |
| Fault Output Supply Voltage (Applied between F_O - V_{NC}) | V_{FO} | -0.5 ~ $V_D+0.5$ | Volts |
| Fault Output Current (Sink Current at F_O Terminal) | I_{FO} | 1 | mA |
| Current Sensing Input Voltage (Applied between C_{IN} - V_{NC}) | V_{SC} | -0.5 ~ $V_D+0.5$ | Volts |

* $V_D = 13.5 \sim 16.5\text{V}$, Inverter Part, $T_j = 125^\circ\text{C}$, Non-repetitive, Less than $2\mu\text{s}$

**The maximum junction temperature rating of the power chips integrated within the DIPIPM is 150°C ($@T_f \leq 100^\circ\text{C}$). However, to ensure safe operation of the DIPIPM, the average junction temperature should be limited to $T_{j(\text{avg})} \leq 125^\circ\text{C}$ ($@T_f \leq 100^\circ\text{C}$).

T_C Measurement Point

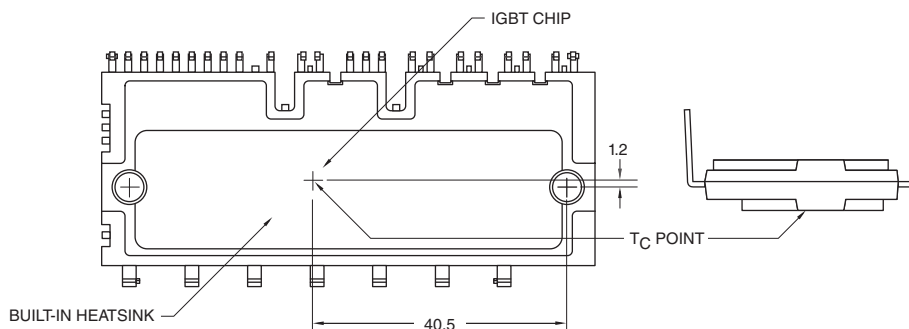

PS22A74
Intellimod™ Module
Dual-In-Line Intelligent Power Module
 15 Amperes/1200 Volts

Electrical and Mechanical Characteristics, $T_j = 25^\circ\text{C}$ unless otherwise specified

| Characteristics | Symbol | Test Conditions | Min. | Typ. | Max. | Units |
|--|---------------|---|------|------|------|---------------|
| IGBT Inverter Sector | | | | | | |
| Collector-Emitter Saturation Voltage | $V_{CE(sat)}$ | $I_C = 15\text{A}, T_j = 25^\circ\text{C}, V_D = V_{DB} = 15\text{V}, V_{IN} = 5\text{V}$ | — | 1.9 | 2.6 | Volts |
| | | $I_C = 15\text{A}, T_j = 125^\circ\text{C}, V_D = V_{DB} = 15\text{V}, V_{IN} = 5\text{V}$ | — | 2.0 | 2.7 | Volts |
| Diode Forward Voltage | V_{EC} | $T_j = 25^\circ\text{C}, -I_C = 15\text{A}, V_{IN} = 0\text{V}$ | — | 2.5 | 3.0 | Volts |
| Inductive Load Switching Times | t_{on} | | 0.8 | 1.5 | 2.2 | μs |
| | t_{rr} | $V_{CC} = 600\text{V}, V_D = V_{DB} = 15\text{V},$ | — | 0.3 | — | μs |
| | $t_{C(on)}$ | $I_C = 15\text{A}, T_j = 125^\circ\text{C}, V_{IN} = 0 \leftrightarrow 5\text{V},$ | — | 0.6 | 0.9 | μs |
| | t_{off} | Inductive Load (Upper-Lower Arm) | — | 2.8 | 3.8 | μs |
| | $t_{C(off)}$ | | — | 0.7 | 1.0 | μs |
| Collector-Emitter Cutoff Current | I_{CES} | $V_{CE} = V_{CES}, T_j = 25^\circ\text{C}$ | — | — | 1.0 | mA |
| | | $V_{CE} = V_{CES}, T_j = 125^\circ\text{C}$ | — | — | 10 | mA |
| Control Sector | | | | | | |
| Circuit Current | I_D | $V_D = V_{DB} = 15\text{V}, V_{IN} = 5\text{V},$ Total of $V_{P1}-V_{PC}, V_{N1}-V_{NC}$ | — | — | 3.70 | mA |
| | | $V_D = V_{DB} = 15\text{V}, V_{IN} = 5\text{V},$ $V_{UFB}-V_{UFS}, V_{VFB}-V_{VFS}, V_{WFB}-V_{WFS}$ | — | — | 1.30 | mA |
| | | $V_D = V_{DB} = 15\text{V}, V_{IN} = 0\text{V},$ Total of $V_{P1}-V_{PC}, V_{N1}-V_{NC}$ | — | — | 3.50 | mA |
| | | $V_D = V_{DB} = 15\text{V}, V_{IN} = 0\text{V},$ $V_{UFB}-V_{UFS}, V_{VFB}-V_{VFS}, V_{WFB}-V_{WFS}$ | — | — | 1.30 | mA |
| | | | | | | |
| Fault Output Voltage | V_{FOH} | $V_{SC} = 0\text{V}, F_O$ Terminal Pull-up to 5V by 10k Ω | 4.9 | — | — | Volts |
| | V_{FOL} | $V_{SC} = 1\text{V}, I_{FO} = 1\text{mA}$ | — | — | 1.1 | Volts |
| Input Current | I_{IN} | $V_{IN} = 5\text{V}$ | 0.7 | 1.5 | 2.0 | mA |
| Short-Circuit Trip Level* | I_{SC} | $-20^\circ\text{C} \leq T_C \leq 100^\circ\text{C}, V_D = 15\text{V}$ | 25.5 | — | — | Amps |
| Supply Circuit Undervoltage Protection | UV_{DBt} | Trip Level, $T_C \leq 100^\circ\text{C}$ | 10.0 | — | 12.0 | Volts |
| | UV_{DBr} | Reset Level, $T_C \leq 100^\circ\text{C}$ | 10.5 | — | 12.5 | Volts |
| | UV_{Dt} | Trip Level, $T_C \leq 100^\circ\text{C}$ | 10.3 | — | 12.5 | Volts |
| | UV_{Dr} | Reset Level, $T_C \leq 100^\circ\text{C}$ | 10.8 | — | 13.0 | Volts |
| Fault Output Pulse Width** | t_{FO} | $C_{FO} = 22\text{nF}$ | 1.6 | 2.4 | — | ms |
| ON Threshold Voltage | $V_{th(on)}$ | Applied between $U_P, V_P, W_P-V_{PC},$ | — | — | 3.5 | Volts |
| OFF Threshold Voltage | $V_{th(off)}$ | U_N, V_N, W_N-V_{NC} | 0.8 | — | — | Volts |
| Temperature Output | V_{OT} | At LVIC Temperature = 85°C | 3.50 | 3.63 | 3.76 | Volts |

* Short-Circuit protection is functioning only at the lower arms. Please select the value of the external shunt resistor such that the SC trip level is less than 85A.

**Fault signal is asserted when the lower arm short circuit or control supply under-voltage protective functions operate. The fault output pulse-width t_{FO} depends on the capacitance value of C_{FO} according to the following approximate equation: $C_{FO} = (12.2 \times 10^{-6} \times t_{FO} [F])$.

***When the temperature rises excessively, the controller (MCU) should stop the DIPIPM.

PS22A74
Intellimod™ Module
Dual-In-Line Intelligent Power Module
 15 Amperes/1200 Volts

Thermal Characteristics, $T_j = 25^\circ\text{C}$ unless otherwise specified

| Characteristic | Symbol | Condition | Min. | Typ. | Max. | Units |
|-------------------------------------|----------------|----------------------------|------|------|------|------------------------------|
| Thermal Resistance Junction to Case | $R_{th(j-c)Q}$ | IGBT Part (Per 1/6 Module) | — | — | 1.15 | $^\circ\text{C}/\text{Watt}$ |
| Thermal Resistance Junction to Case | $R_{th(j-c)D}$ | FWDI Part (Per 1/6 Module) | — | — | 1.36 | $^\circ\text{C}/\text{Watt}$ |

Recommended Conditions for Use

| Characteristic | Symbol | Condition | Min. | Typ. | Max. | Units |
|------------------------------------|---|---|------|------|------|------------------|
| Supply Voltage | V_{CC} | Applied between P-NU, NV, NW | 350 | 600 | 800 | Volts |
| Control Supply Voltage | V_D | Applied between V_{P1} - V_{PC} , V_{N1} - V_{NC} | 13.5 | 15.0 | 16.5 | Volts |
| | V_{DB} | Applied between V_{UFB} - V_{UFS} , V_{VFB} - V_{VFS} , V_{WFB} - V_{WFS} | 13.0 | 15.0 | 18.5 | Volts |
| Control Supply Variation | ΔV_D , ΔV_{DB} | | -1 | — | 1 | V/ μs |
| Arm Shoot-through Blocking Time | t_{DEAD} | For Each Input Signal, $T_C \leq 100^\circ\text{C}$ | 3.3 | — | — | μs |
| PWM Input Frequency | f_{PWM} | $T_C \leq 100^\circ\text{C}$, $T_j \leq 125^\circ\text{C}$ | — | — | 15 | kHz |
| Allowable rms Current* | I_O | $V_{CC} = 600\text{V}$, $V_D = 15\text{V}$, $f_C = 15\text{kHz}$, $\text{PF} = 0.8$, Sinusoidal PWM, $T_j \leq 125^\circ\text{C}$, $T_C \leq 100^\circ\text{C}$ | — | — | 5.5 | Arms |
| Minimum Input Pulse Width | $P_{WIN(on)}^{**}$ | | — | — | — | μs |
| Pulse Width | $P_{WIN(off)}^{***}$ | | — | — | — | μs |
| | $I_C \leq 5\text{A}$ $15 \leq I_C \leq 25.5\text{A}$ | $350 \leq V_{CC} \leq 800\text{V}$, $13.5 \leq V_D \leq 16.5\text{V}$, $13.5 \leq V_{DB} \leq 16.5\text{V}$, $-20^\circ\text{C} \leq T_C \leq 100^\circ\text{C}$, N-line Wiring Inductance Less Than 10nH | — | — | — | μs |
| V_{NC} Variation | V_{NC} | Between V_{NC} -NU, NV, NW (Including Surge) | -5.0 | — | 5.0 | Volts |

* The allowable rms current value depends on the actual application conditions.

**If input signal ON pulse is less than $P_{WIN(on)}$, the device may not respond.

***The IPM may fail to respond to an ON pulse if the preceding OFF pulse is less than $P_{WIN(off)}$.

Delayed Response Against Shorter Input OFF Signal Than $P_{WIN(off)}$, P-side only

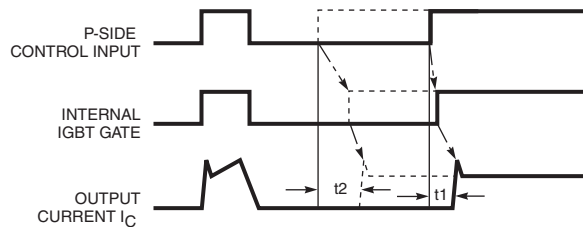

Solid Line – OFF Pulse Width $> P_{WIN(off)}$: Turn ON time t_1 .

Dotted Line – OFF Pulse Width $< P_{WIN(off)}$: Turn ON time t_2 .

PS22A74
Intellimod™ Module
Dual-In-Line Intelligent Power Module
 15 Amperes/1200 Volts

Application Circuit

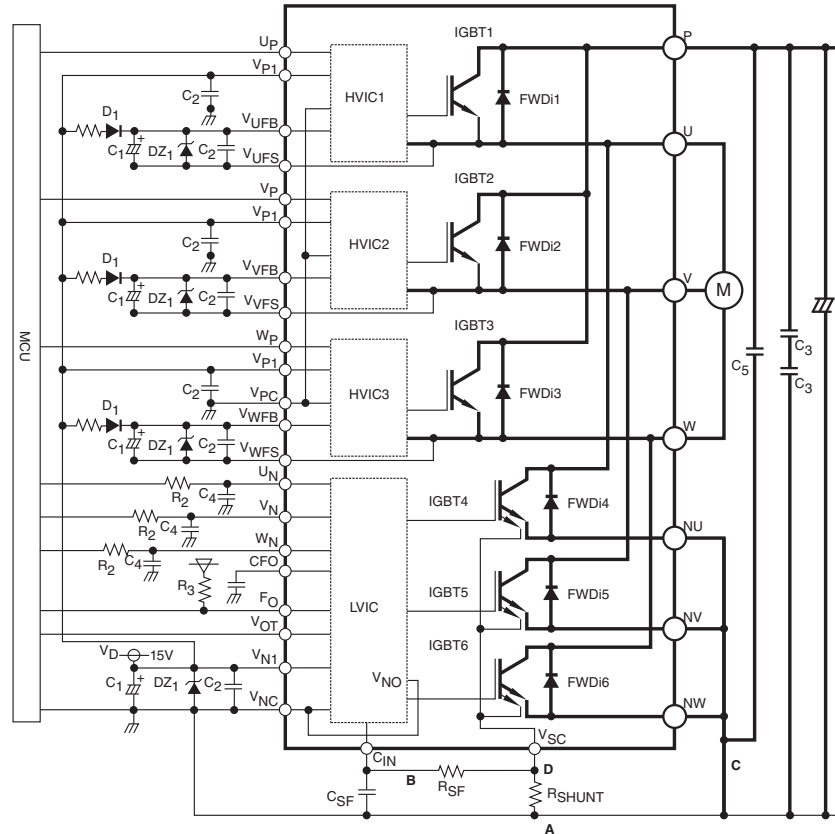

Component Selection:

| Dsgn. | Typ. Value | Description |
|--------------------|---------------------|--|
| D ₁ | 1A, 600V | Control and boot strap supply overvoltage suppression |
| DZ ₁ | 24V, 1W | Control and boot strap supply over voltage suppression |
| C ₁ | 10-100µF, 50V | Boot strap supply reservoir – electrolytic long life low impedance, 105°C |
| C ₂ | 0.22-2.0µF, 50V | Local decoupling/High frequency noise filters – multilayer ceramic (Note 4) |
| C ₃ | 200 to 2500µF, 450V | Main DC bus filter capacitor – electrolytic, long life, high ripple current, 105°C |
| C ₄ | 100pF, 50V | Optional input signal noise filter – multilayer ceramic (Note 11) |
| C ₅ | 0.1-0.22µF, 1000V | Surge voltage suppression (Note 2) |
| C _{SF} | 1000pF, 50V | Short circuit detection filter capacitor – multilayer ceramic |
| R _{SF} | 1.8kΩ | Short circuit detection filter resistor |
| R _{SHUNT} | 20ohm-500ohm | Current sensing resistor |
| R ₁ | 1-10Ω | Boot strap supply inrush limiting resistor – non-inductive, temperature stable, tight tolerance (Note 5) |
| R ₂ | 330Ω | Optional input signal noise filter (Note 11) |
| R ₃ | 10kΩ | Fault signal pull-up resistor (Note 9) |

Notes:

- If control GND is connected to power GND by broad pattern, it may cause malfunction by power GND fluctuation. It is recommended to connect control GND at only a point at which NU, NV, NW are connected to power GND line.
- To prevent surge destruction, the wiring between the smoothing capacitor and the P-N1 terminals should be as short as possible. Generally inserting a 0.1µ – 0.22µF snubber capacitor C₃ between the P-N1 terminals is recommended.
- The time constant R₁, C₄ of RC filter for preventing the protection circuit malfunction should be selected in the range of 1.5µ – 2µs. SC interrupting time might vary with the wiring pattern. Tight tolerance, temp-compensated type is recommended for R₁, C₄.
- All capacitors should be mounted as close to the terminals of the DIPIM as possible. (C₁: good temperature, frequency characteristics electrolytic type, and C₂: good temperature, frequency and DC bias characteristic ceramic type are recommended.)
- It is recommended to insert a Zener diode DZ₁ (24V/1W) between each pair of control supply terminals to prevent surge destruction.
- To prevent erroneous SC protection, the wiring from V_{SC} terminals to C_{IN} filter should be divided at the point D that is close to the terminal of sense resistor and the wiring should be patterned as short as possible.
- For sense resistor, the variation within 1% (including temperature characteristics), low inductance type is recommended. 1/8W is recommended, but an evaluation of your system is recommended.
- To prevent erroneous operation, wiring A, B, and C should be as short as possible.
- F_O output is open drain type. It should be pulled up to the positive side of 5V or 15V power supply with a resistor that limits F_O sink current (I_{F_O}) under 1mA. (Over 5.1kΩ is needed and 10kΩ is recommended for 5V supply.)
- Error signal output width (t_{F_O}) can be set by the capacitor connected to the C_{F_O} terminal. t_{F_O}(typ) = C_{F_O} / 9.1 x 10⁻⁶ (s).
- Input drive is high-active type. There is a 3.3kΩ pull-down resistor integrated in the IC input circuit. To prevent malfunction, the wiring of each input should be patterned as short as possible. When inserting the RC filter, make sure the input signal level meets the turn-on and turn-off threshold voltage. Thanks to HVIC inside the module, connection to the MCU may be direct or with an opto-coupler.

PS22A74
Intellimod™ Module
Dual-In-Line Intelligent Power Module
 15 Amperes/1200 Volts

Protection Function Timing Diagrams

Short Circuit Protection (N-side Only with External Shunt Resistor and RC Filter)

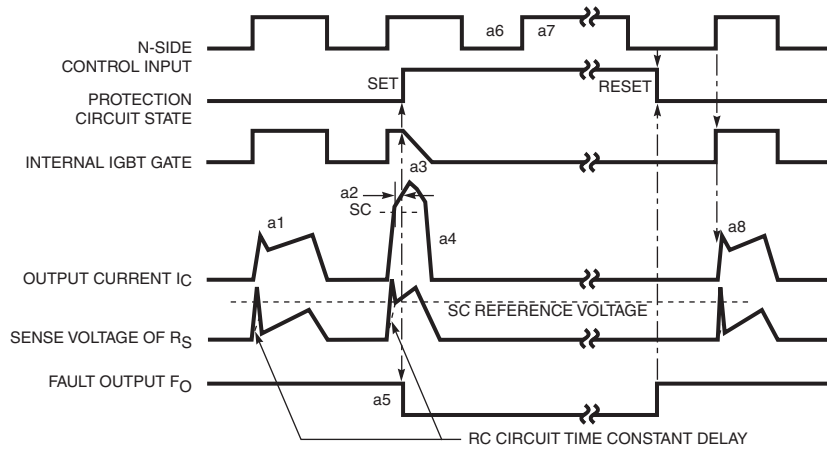

- a1: Normal operation – IGBT turns on and carries current.
- a2: Short circuit current is detected (SC trigger).
- a3: All N-side IGBT's gate are hard interrupted.
- a4: All N-side IGBT's turn off.
- a5: F_O output with a fixed pulse width (determined by the external capacitance C_{FO}).
- a6: Input "L" – IGBT off.
- a7: Input "H" – IGBT on, but during the F_O output period the IGBT will not turn on.
- a8: IGBT turns on when L→H signal is input after F_O is reset.

Under-Voltage Protection (N-side , UV_D)

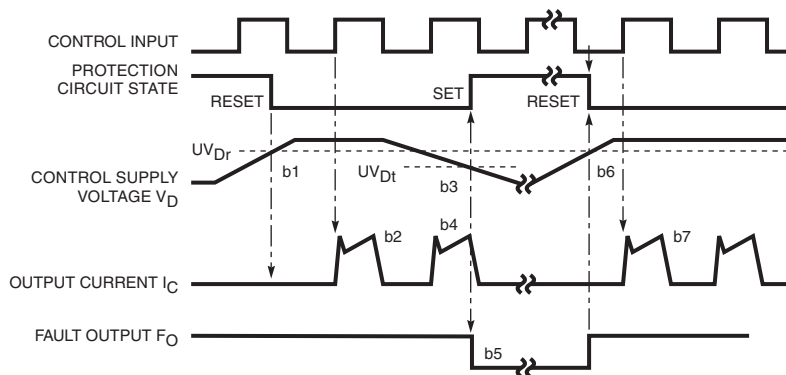

- b1: Control supply voltage V_D rises – After V_D level reaches under voltage reset level (UV_{Dr}), the circuits start to operate when next input is applied.
- b2: Normal operation – IGBT turns on and carries current.
- b3: V_D level dips to under voltage trip level (UV_{Dt}).
- b4: All N-side IGBT's turn off in spite of control input condition.
- b5: F_O is low for a minimum period determined by the capacitance C_{FO} but continuously during UV period.
- b6: V_D level reaches UV_{Dr} .
- b7: Normal operation – IGBT turns on and carries current.

PS22A74
Intellimod™ Module
Dual-In-Line Intelligent Power Module
 15 Amperes/1200 Volts

Protection Function Timing Diagrams

Under-Voltage Protection (P-side, UV_{DB})

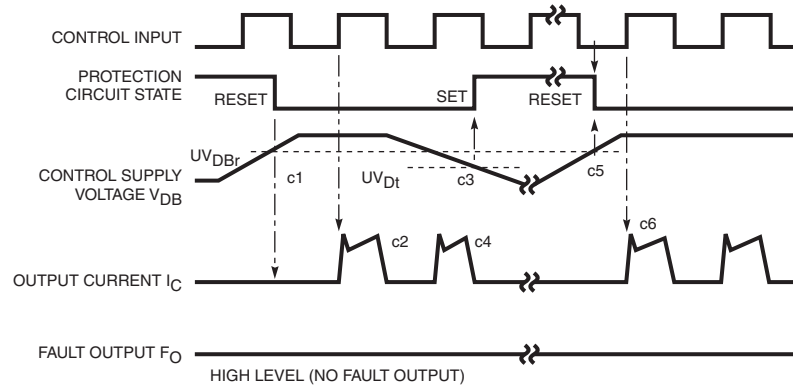

- c1: Control supply voltage V_{DB} rises – After V_{DB} level reaches under voltage reset level (UV_{DBr}), the circuits starts to operate when next input is applied.
- c2: Normal operation – IGBT turns on and carries current.
- c3: V_{DB} level dips to under voltage trip level (UV_{Dt}).
- c4: P-side IGBT turns off in spite of control input signal level, but there is no F_O signal output.
- c5: V_{DB} level reaches UV_{DBr} .
- c6: Normal operation – IGBT on and carries current.

Typical Interface Circuit

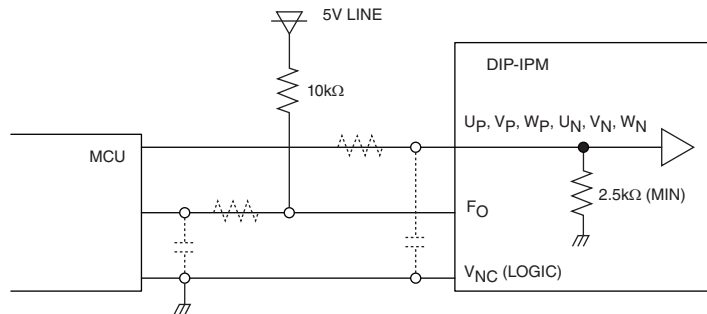

NOTE: RC coupling at each input (parts shown dotted) may change depending on the PWM control scheme used in the application and the wiring impedance of the printed circuit board. The DIP-IPM input signal section integrates a 2.5kΩ (min) pull-down resistor. Therefore, when using an external filtering resistor, care must be taken to satisfy the turn-on threshold voltage requirement.

Wiring Method Around Shunt Resistor

