

Numonyx® Axcell™ Flash Memory (P30-65nm)

256-Mbit, 512-Mbit (256M/256M)

Datasheet

Product Features

- High performance
 - 100 ns initial access for Easy BGA
 - 110 ns initial access for TSOP
 - 25 ns 16-word asynchronous-page read mode
 - 52 MHz (Easy BGA) with zero WAIT states, 17ns clock-to-data output synchronous-burst read mode
 - 4-, 8-, 16-, and continuous-word options for burst mode
 - Buffered Enhanced Factory Programming (BEFP) at 2.0 MByte/s (Typ) using 512-word buffer
 - 1.8 V buffered programming at 1.14 MByte/s (Typ) using 512-word buffer
- Architecture
 - Multi-Level Cell Technology: Highest Density at Lowest Cost
 - Asymmetrically-blocked architecture
 - Four 32-KByte parameter blocks: top or bottom configuration
 - 128-KByte main blocks
 - Blank Check to verify an erased block
- Voltage and Power
 - V_{CC} (core) voltage: 1.7 V – 2.0 V
 - V_{CCQ} (I/O) voltage: 1.7 V – 3.6 V
 - Standby current: 65 μ A (Typ) for 256-Mbit;
 - 52 MHz continuous synchronous read current: 21mA (Typ)/24mA(Max)
- Security
 - One-Time Programmable Register:
 - 64 OTP bits, programmed with unique information by Numonyx
 - 2112 OTP bits, available for customer programming
 - Absolute write protection: $V_{PP} = V_{SS}$
 - Power-transition erase/program lockout
 - Individual zero-latency block locking
 - Individual block lock-down
 - Password Access feature
- Software
 - 25 μ s (Typ) program suspend
 - 25 μ s (Typ) erase suspend
 - Numonyx™ Flash Data Integrator optimized
 - Basic Command Set and Extended Function Interface (EFI) Command Set compatible
 - Common Flash Interface capable
- Density and Packaging
 - 56-Lead TSOP package (256-Mbit only)
 - 64-Ball Easy BGA package (256, 512-Mbit)
 - Numonyx™ QUAD+ SCSP (256, 512-Mbit)
 - 16-bit wide data bus
- Quality and Reliability
 - JESD47E Compliant
 - Operating temperature: –40 °C to +85 °C
 - Minimum 100,000 erase cycles per block
 - 65nm process technology

INFORMATION IN THIS DOCUMENT IS PROVIDED IN CONNECTION WITH NUMONYX™ PRODUCTS. NO LICENSE, EXPRESS OR IMPLIED, BY ESTOPPEL OR OTHERWISE, TO ANY INTELLECTUAL PROPERTY RIGHTS IS GRANTED BY THIS DOCUMENT. EXCEPT AS PROVIDED IN NUMONYX'S TERMS AND CONDITIONS OF SALE FOR SUCH PRODUCTS, NUMONYX ASSUMES NO LIABILITY WHATSOEVER, AND NUMONYX DISCLAIMS ANY EXPRESS OR IMPLIED WARRANTY, RELATING TO SALE AND/OR USE OF NUMONYX PRODUCTS INCLUDING LIABILITY OR WARRANTIES RELATING TO FITNESS FOR A PARTICULAR PURPOSE, MERCHANTABILITY, OR INFRINGEMENT OF ANY PATENT, COPYRIGHT OR OTHER INTELLECTUAL PROPERTY RIGHT. Numonyx products are not intended for use in medical, life saving, life sustaining, critical control or safety systems, or in nuclear facility applications.

Numonyx B.V. may make changes to specifications and product descriptions at any time, without notice.

Numonyx B.V. may have patents or pending patent applications, trademarks, copyrights, or other intellectual property rights that relate to the presented subject matter. The furnishing of documents and other materials and information does not provide any license, express or implied, by estoppel or otherwise, to any such patents, trademarks, copyrights, or other intellectual property rights.

Designers must not rely on the absence or characteristics of any features or instructions marked "reserved" or "undefined." Numonyx reserves these for future definition and shall have no responsibility whatsoever for conflicts or incompatibilities arising from future changes to them.

Contact your local Numonyx sales office or your distributor to obtain the latest specifications and before placing your product order.

Copies of documents which have an order number and are referenced in this document, or other Numonyx literature may be obtained by visiting Numonyx's website at <http://www.numonyx.com>.

Numonyx, the Numonyx logo, and Axcell are trademarks or registered trademarks of Numonyx B.V. or its subsidiaries in other countries.

*Other names and brands may be claimed as the property of others.

Copyright © 2010, Numonyx, B.V., All Rights Reserved.

Contents

1.0	Functional Description	5
1.1	Introduction	5
1.2	Overview	5
1.3	Virtual Chip Enable Description.....	6
1.4	Memory Maps	7
2.0	Package Information	8
2.1	56-Lead TSOP.....	8
2.2	64-Ball Easy BGA Package.....	10
2.3	QUAD+ SCSP Packages.....	11
3.0	Ballouts	13
4.0	Signals	16
4.1	Dual-Die Configurations	18
5.0	Bus Operations	19
5.1	Reads	19
5.2	Writes.....	19
5.3	Output Disable.....	19
5.4	Standby	20
5.5	Reset.....	20
6.0	Command Set	21
6.1	Device Command Codes.....	21
6.2	Device Command Bus Cycles	22
7.0	Read Operation	25
7.1	Asynchronous Page-Mode Read	25
7.2	Synchronous Burst-Mode Read.....	25
7.3	Read Device Identifier.....	26
7.4	Read CFI.....	26
8.0	Program Operation	27
8.1	Word Programming	27
8.2	Buffered Programming	27
8.3	Buffered Enhanced Factory Programming.....	28
8.4	Program Suspend.....	31
8.5	Program Resume.....	31
8.6	Program Protection.....	31
9.0	Erase Operations	33
9.1	Block Erase	33
9.2	Blank Check	33
9.3	Erase Suspend	34
9.4	Erase Resume.....	34
9.5	Erase Protection	34
10.0	Security Modes	35
10.1	Block Locking.....	35
10.2	Selectable One-Time Programmable Blocks.....	37
10.3	Password Access	37
11.0	Registers	38
11.1	Read Status Register	38
11.2	Read Configuration Register.....	39

11.3	One-Time-Programmable (OTP) Registers	45
12.0	Power and Reset Specifications	48
12.1	Power-Up and Power-Down	48
12.2	Reset Specifications	48
12.3	Power Supply Decoupling	49
13.0	Maximum Ratings and Operating Conditions	50
13.1	Absolute Maximum Ratings	50
13.2	Operating Conditions	50
14.0	Electrical Specifications	51
14.1	DC Current Characteristics	51
14.2	DC Voltage Characteristics	52
15.0	AC Characteristics	53
15.1	AC Test Conditions	53
15.2	Capacitance	54
15.3	AC Read Specifications	54
15.4	AC Write Specifications	59
16.0	Program and Erase Characteristics	63
17.0	Ordering Information	64
17.1	Discrete Products	64
17.2	SCSP Products	65
A	Supplemental Reference Information	66
A.1	Common Flash Interface Tables	66
A.2	Flowcharts	78
A.3	Write State Machine	87
B	Conventions - Additional Information	91
B.1	Conventions	91
B.2	Acronyms	91
B.3	Nomenclature	92
C	Revision History	93

1.0 Functional Description

1.1 Introduction

This document provides information about the Numonyx® Axcell™ Flash Memory (P30-65nm) product and describes its features, operations, and specifications.

The Numonyx® Axcell™ Flash Memory (P30-65nm) is the latest generation of flash memory devices. P30-65nm device will be offered in 64-Mbit up through 2-Gbit densities. This document covers specifically 256-Mbit and 512-Mbit (256M/256M) product information. Benefits include more density in less space, high-speed interface device, and support for code and data storage. Features include high-performance synchronous-burst read mode, fast asynchronous access times, low power, flexible security options, and three industry-standard package choices. The P30-65nm product family is manufactured using Numonyx 65nm process technology.

1.2 Overview

This section provides an overview of the features and capabilities of the P30-65nm.

The P30-65nm family devices provides high performance at low voltage on a 16-bit data bus. Individually erasable memory blocks are sized for optimum code and data storage.

Upon initial power up or return from reset, the device defaults to asynchronous page-mode read. Configuring the Read Configuration Register enables synchronous burst-mode reads. In synchronous burst mode, output data is synchronized with a user-supplied clock signal. A WAIT signal provides easy CPU-to-flash memory synchronization.

In addition to the enhanced architecture and interface, the device incorporates technology that enables fast factory program and erase operations. Designed for low-voltage systems, the P30-65nm supports read operations with V_{CC} at 1.8 V, and erase and program operations with V_{PP} at 1.8 V or 9.0 V. Buffered Enhanced Factory Programming (BEFP) provides the fastest flash array programming performance with V_{PP} at 9.0 V, which increases factory throughput. With V_{PP} at 1.8 V, V_{CC} and V_{PP} can be tied together for a simple, ultra low power design. In addition to voltage flexibility, a dedicated VPP connection provides complete data protection when $V_{PP} \leq V_{PPLK}$.

A Command User Interface (CUI) is the interface between the system processor and all internal operations of the device. An internal Write State Machine (WSM) automatically executes the algorithms and timings necessary for block erase and program. A Status Register indicates erase or program completion and any errors that may have occurred.

An industry-standard command sequence invokes program and erase automation. Each erase operation erases one block. The Erase Suspend feature allows system software to pause an erase cycle to read or program data in another block. Program Suspend allows system software to pause programming to read other locations. Data is programmed in word increments (16 bits).

The P30-65nm protection register allows unique flash device identification that can be used to increase system security. The individual Block Lock34

feature provides zero-latency block locking and unlocking. The P30-65nm device includes enhanced protection via Password Access; this new feature allows write and/or read access protection of user-defined blocks. In addition, the P30-65nm device also provides the One-Time Programmable (OTP) security feature backward compatible to the P30-130nm device.

1.3 Virtual Chip Enable Description

The P30-65nm 512-Mbit devices employ a Virtual Chip Enable which combines two 256-Mbit die with a common chip enable, F1-CE# for QUAD+ packages or CE# for Easy BGA packages. Refer to [Figure 9 on page 18](#) and [Figure 10 on page 18](#) for detail. The maximum address bit is then used to select between the die pair with F1-CE#/CE# asserted depending upon the package option used. When chip enable is asserted and The maximum address bit is low (V_{IL}), The lower parameter die is selected; when chip enable is asserted and the maximum address bit is high (V_{IH}), the upper parameter die is selected. Refer to [Table 1](#) and [Table 2](#) for additional details.

Table 1: Virtual Chip Enable Truth Table for 512 Mb (QUAD+ Package)

Die Selected	F1-CE#	A24
Lower Param Die	L	L
Upper Param Die	L	H

Table 2: Virtual Chip Enable Truth Table for 512 Mb (Easy BGA Packages)

Die Selected	CE#	A25
Lower Param Die	L	L
Upper Param Die	L	H

1.4 Memory Maps

Figure 1: P30-65nm Memory Map

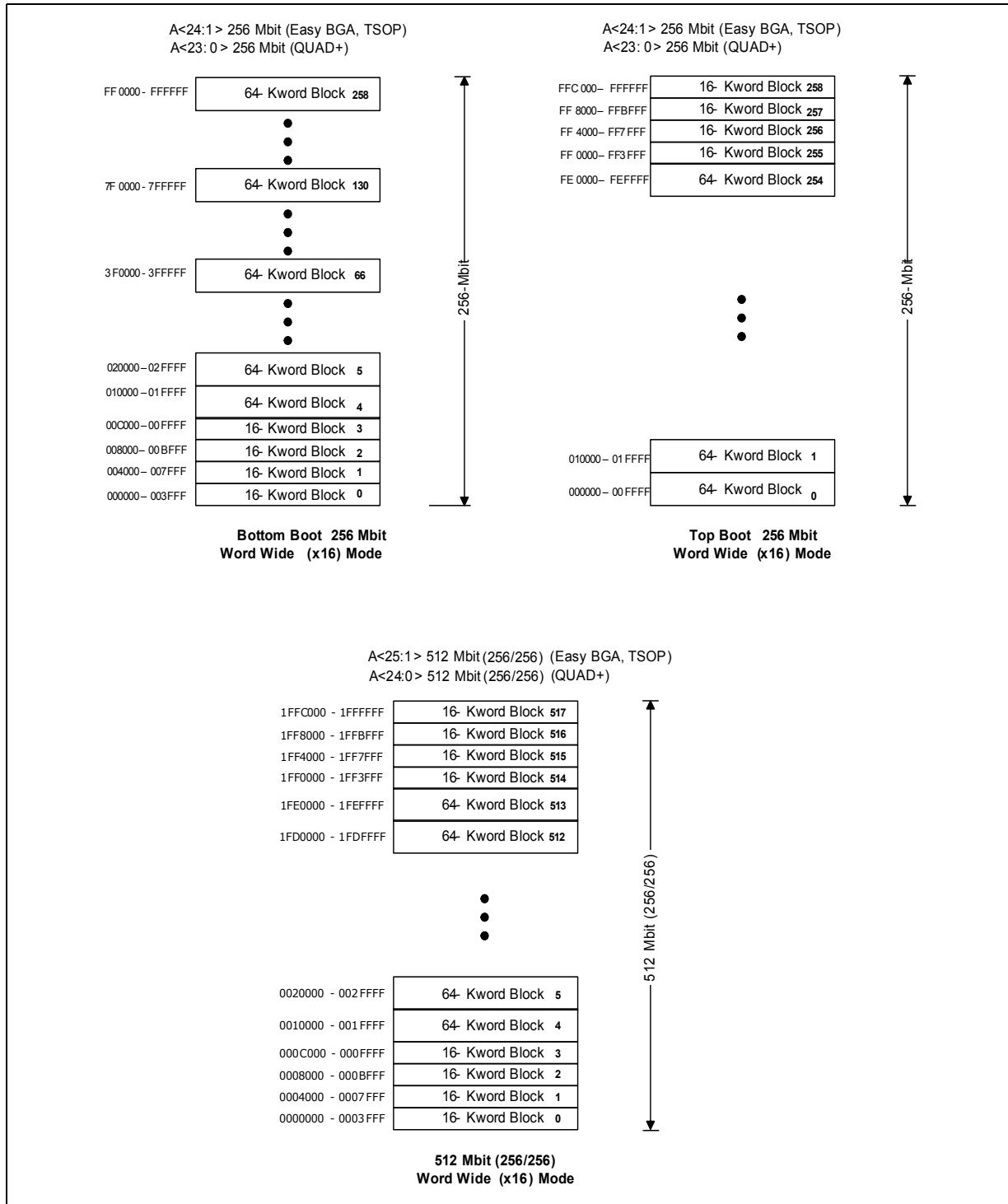

2.0 Package Information

2.1 56-Lead TSOP

Figure 2: TSOP Mechanical Specifications (256-Mbit)

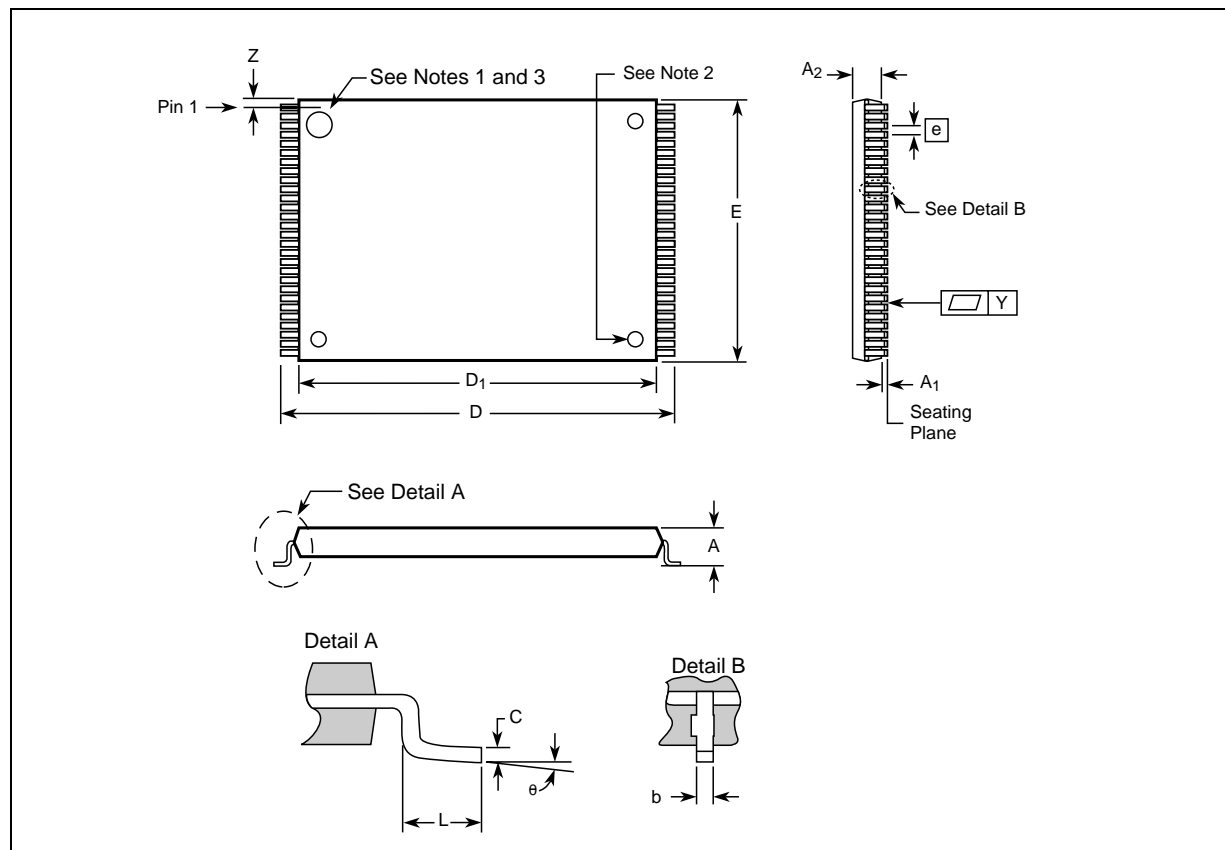

Table 3: TSOP Package Dimensions (Sheet 1 of 2)

Product Information	Symbol	Millimeters			Inches		
		Min	Nom	Max	Min	Nom	Max
Package Height	A	-	-	1.200	-	-	0.047
Standoff	A ₁	0.050	-	-	0.002	-	-
Package Body Thickness	A ₂	0.965	0.995	1.025	0.038	0.039	0.040
Lead Width	b	0.100	0.150	0.200	0.004	0.006	0.008
Lead Thickness	C	0.100	0.150	0.200	0.004	0.006	0.008
Package Body Length	D ₁	18.200	18.400	18.600	0.717	0.724	0.732
Package Body Width	E	13.800	14.000	14.200	0.543	0.551	0.559
Lead Pitch	e	-	0.500	-	-	0.0197	-
Terminal Dimension	D	19.800	20.00	20.200	0.780	0.787	0.795

Table 3: TSOP Package Dimensions (Sheet 2 of 2)

Product Information	Symbol	Millimeters			Inches		
		Min	Nom	Max	Min	Nom	Max
Lead Tip Length	L	0.500	0.600	0.700	0.020	0.024	0.028
Lead Count	N	-	56	-	-	56	-
Lead Tip Angle	θ	0°	3°	5°	0°	3°	5°
Seating Plane Coplanarity	Y	-	-	0.100	-	-	0.004
Lead to Package Offset	Z	0.150	0.250	0.350	0.006	0.010	0.014

Notes:

1. One dimple on package denotes Pin 1.
2. If two dimples, then the larger dimple denotes Pin 1.
3. Pin 1 will always be in the upper left corner of the package, in reference to the product mark..

2.2 64-Ball Easy BGA Package

Figure 3: Easy BGA Mechanical Specifications (256-Mbit, 512-Mbit)

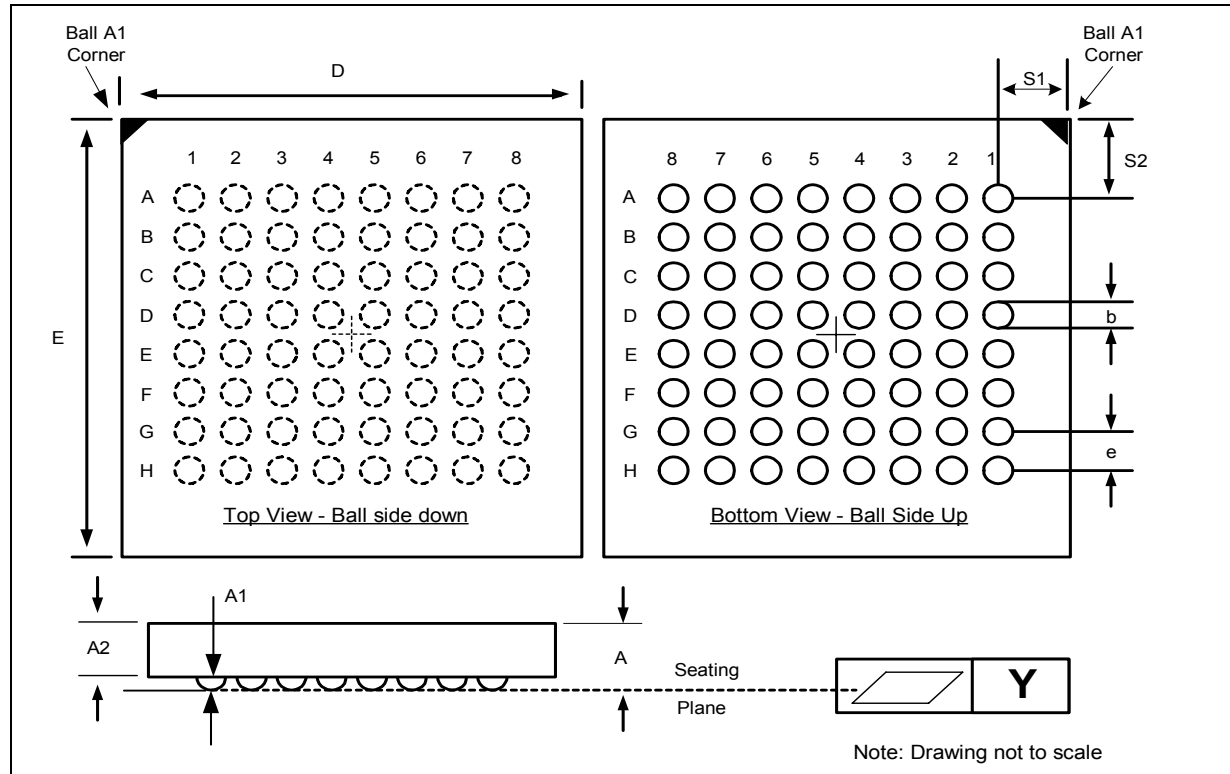

Table 4: Easy BGA Package Dimensions

Product Information	Symbol	Millimeters			Inches		
		Min	Nom	Max	Min	Nom	Max
Package Height	A	-	-	1.200	-	-	0.0472
Ball Height	A1	0.250	-	-	0.0098	-	-
Package Body Thickness	A2	-	0.780	-	-	0.0307	-
Ball (Lead) Width	b	0.330	0.430	0.530	0.0130	0.0169	0.0209
Package Body Width	D	9.900	10.000	10.100	0.3898	0.3937	0.3976
Package Body Length	E	12.900	13.000	13.100	0.5079	0.5118	0.5157
Pitch	e	-	1.000	-	-	0.0394	-
Ball (Lead) Count	N	-	64	-	-	64	-
Seating Plane Coplanarity	Y	-	-	0.100	-	-	0.0039
Corner to Ball A1 Distance Along D	S1	1.400	1.500	1.600	0.0551	0.0591	0.0630
Corner to Ball A1 Distance Along E	S2	2.900	3.000	3.100	0.1142	0.1181	0.1220

Note: One dimple on package denotes Pin 1, which will always be in the upper left corner of the package, in reference to the product mark.

2.3 QUAD+ SCSP Packages

Figure 4: 88-ball (80 active) QUAD+ SCSP Specifications (256-Mbit, 8x11x1.0 mm)

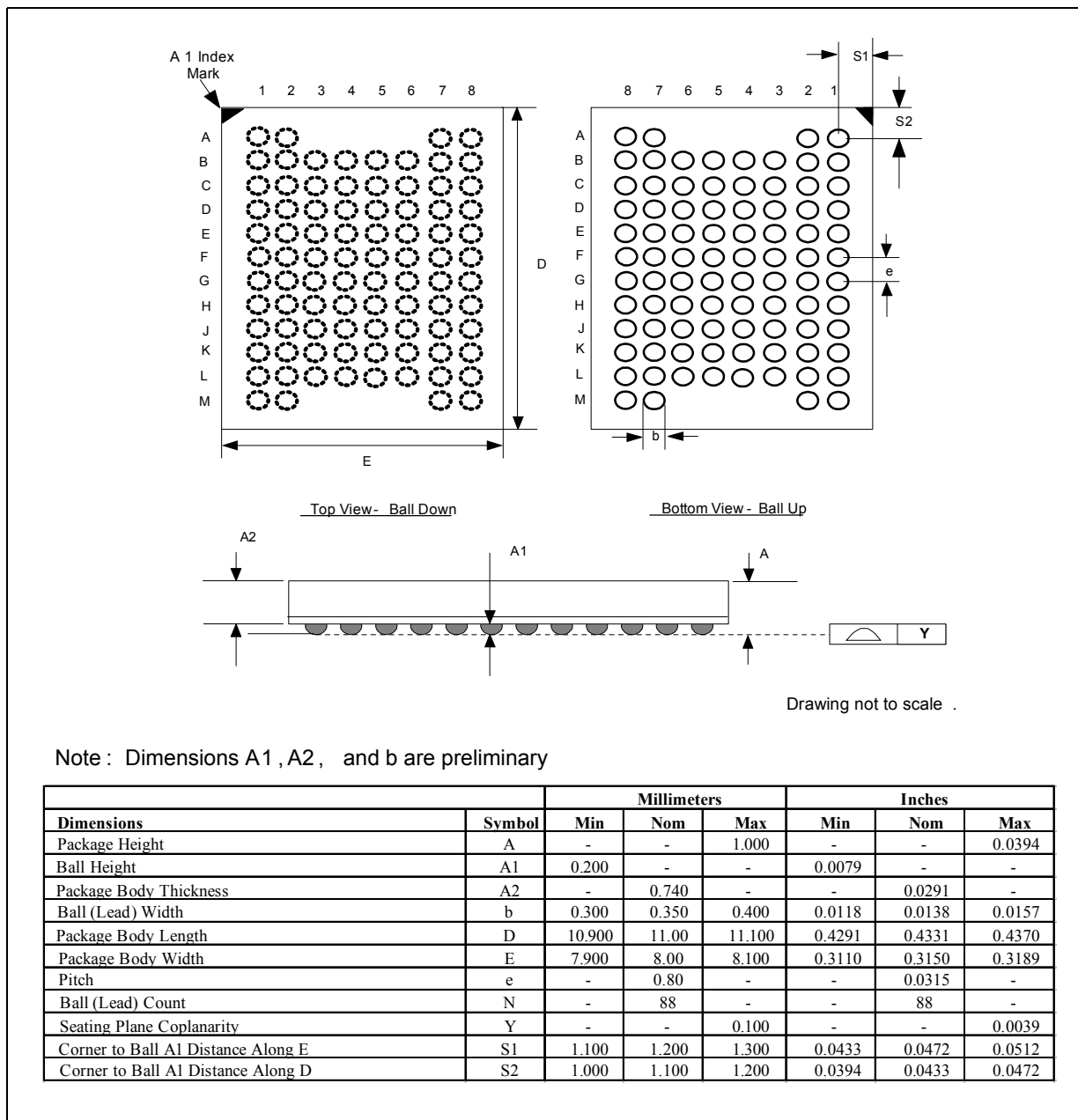
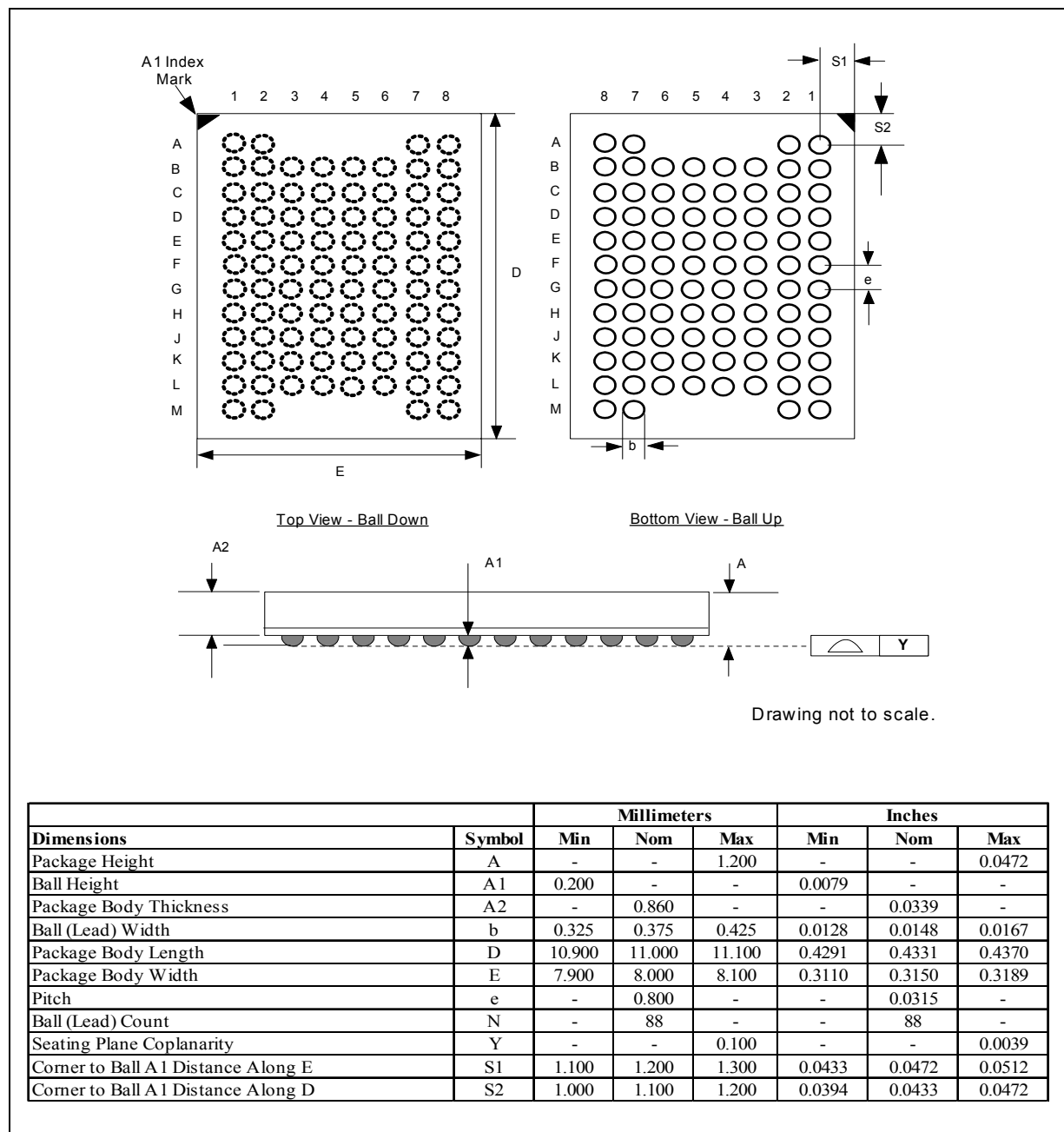
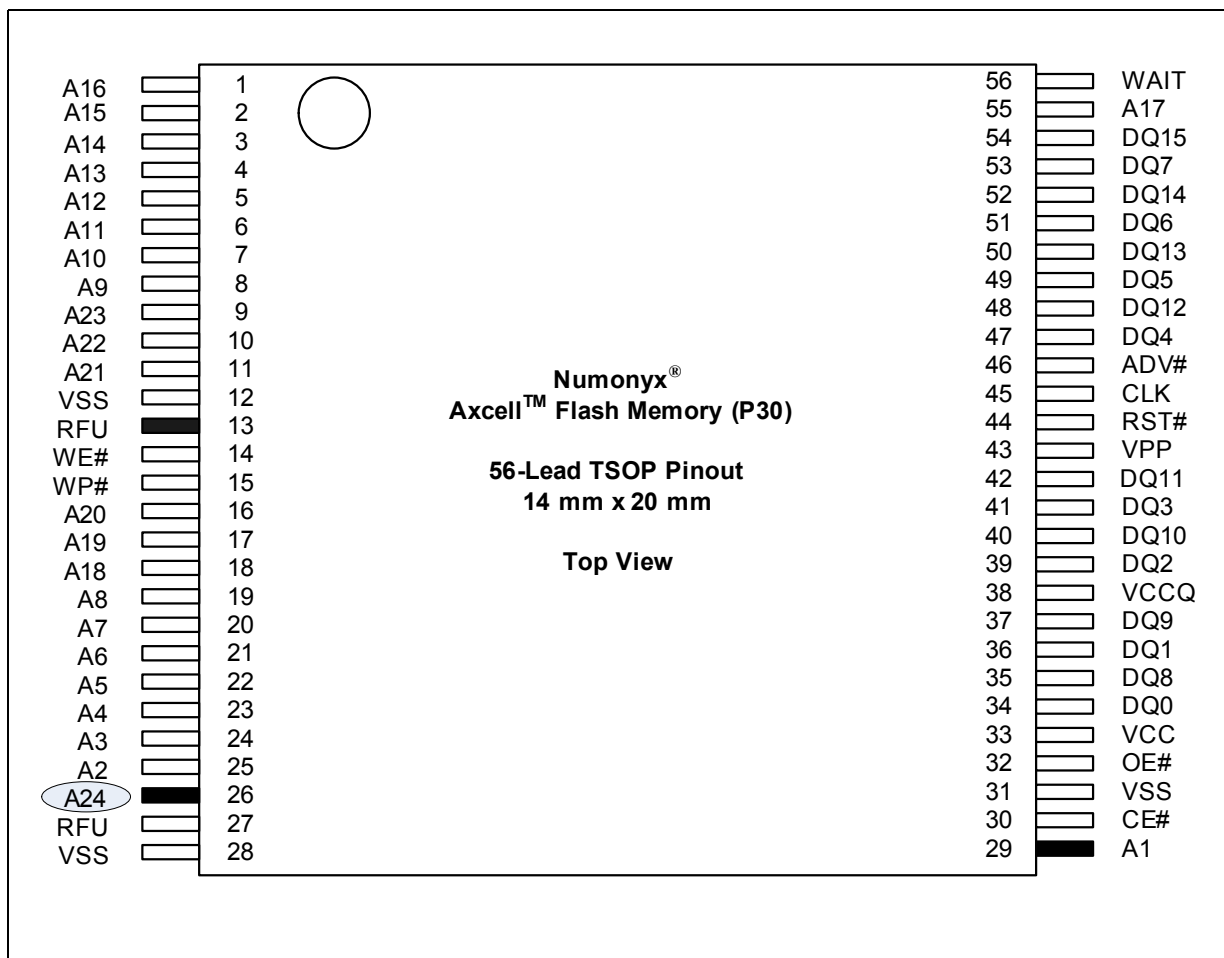

Figure 5: 88-ball (80 active) QUAD+ SCSP Specifications (512-Mbit, 8x11x1.2 mm)



3.0 Ballouts

Figure 6: 56-Lead TSOP Pinout (256-Mbit)



Notes:

1. A1 is the least significant address bit.
2. A24 is valid for 256-Mbit densities; otherwise, it is a no connect (NC).
3. No Internal Connection on Pin 13; it may be driven or floated. For legacy designs, it is VCC pin and can be tied to Vcc.
4. One dimple on package denotes Pin 1 which will always be in the upper left corner of the package, in reference to the product mark.

Figure 7: 64-Ball Easy BGA Ballout (256-Mbit, 512-Mbit)

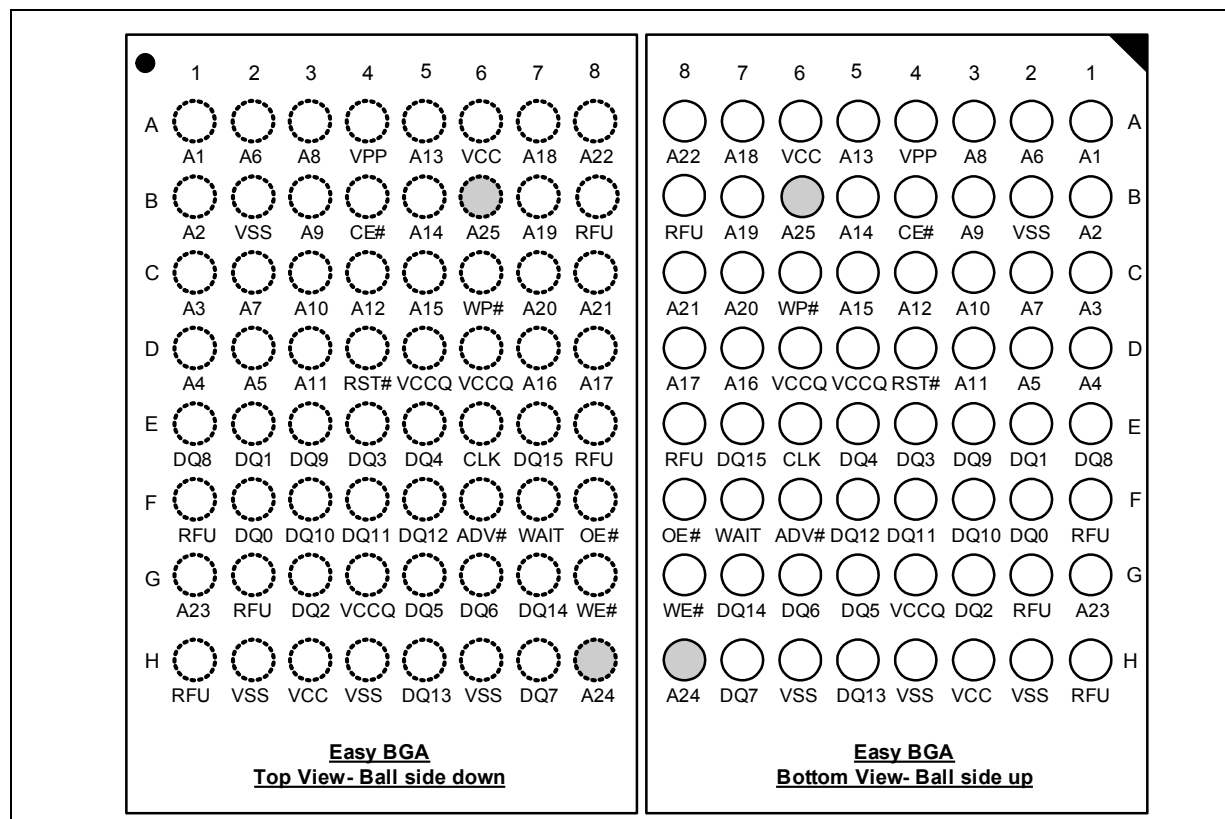

Notes:

1. A1 is the least significant address bit.
2. A24 is valid for 256-Mbit densities and above; otherwise, it is a no connect (NC).
3. A25 is valid for 512-Mbit densities; otherwise, it is a no connect (NC).
4. One dimple on package denotes A1 Pin which will always be in the upper left corner of the package, in reference to the product mark.

Figure 8: QUAD+ SCSP Ballout and Signals

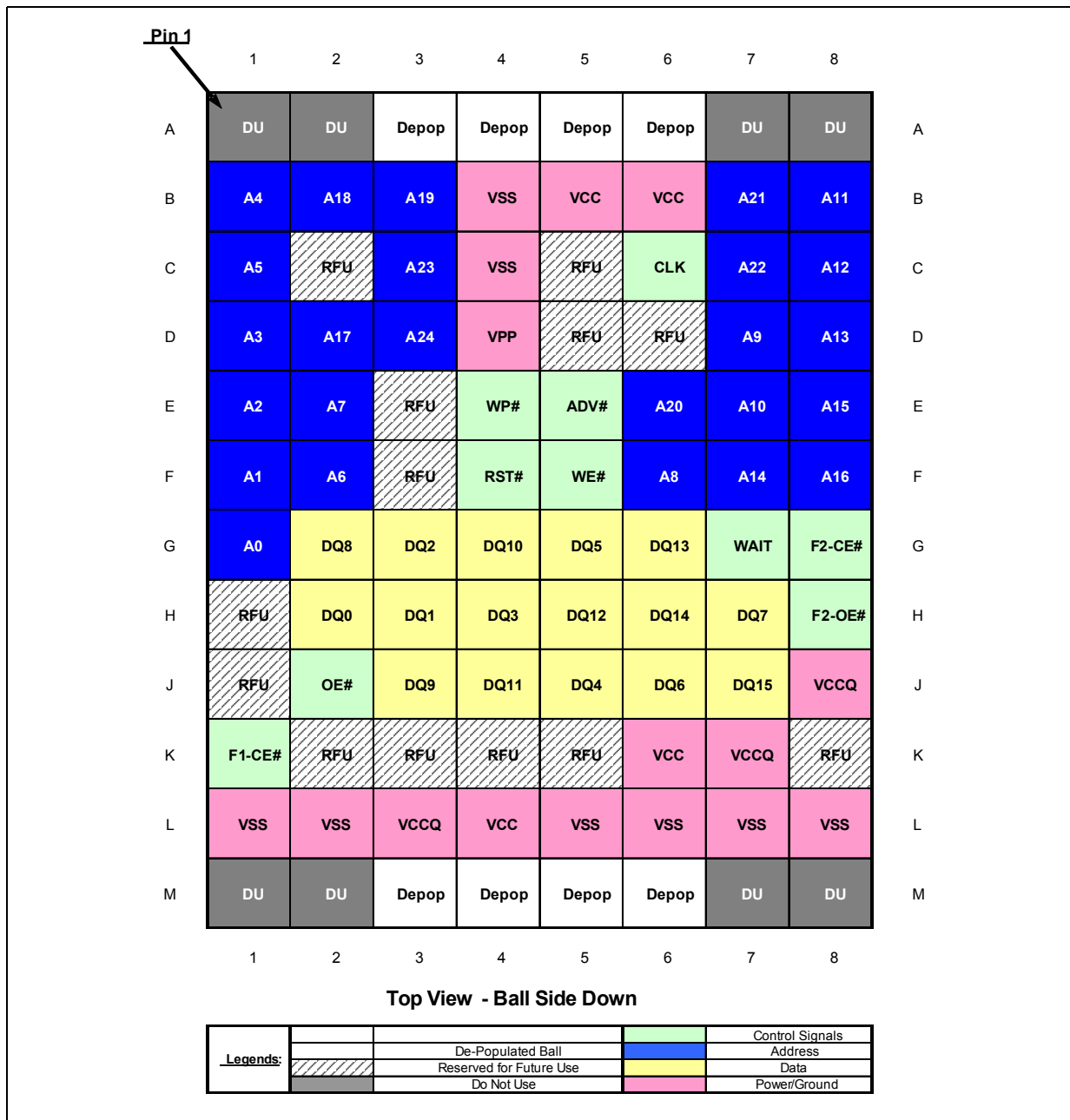

Notes:

1. A23 is valid for 256-Mbit densities and above; otherwise, it is a no connect (NC).
2. A24 is valid for 512-Mbit densities; otherwise, it is a no connect (NC).
3. F2-CE# and F2-OE# are no connect (NC) for all densities.
4. A0 is LSB for Address.

4.0 Signals

This section has signal descriptions for the various P30-65nm packages.

Table 5: TSOP and Easy BGA Signal Descriptions (Sheet 1 of 2)

Symbol	Type	Name and Function
A[MAX:1]	Input	ADDRESS INPUTS: Device address inputs. 256-Mbit: A[24:1]; 512-Mbit: A[25:1]. <i>Note:</i> The virtual selection of the 256-Mbit "Top parameter" die in the dual-die 512-Mbit configuration is accomplished by setting A25 high (V_{IH}).
DQ[15:0]	Input/Output	DATA INPUT/OUTPUTS: Inputs data and commands during write cycles; outputs data during memory, Status Register, Protection Register, and Read Configuration Register reads. Data balls float when the CE# or OE# are deasserted. Data is internally latched during writes.
ADV#	Input	ADDRESS VALID: Active low input. During synchronous read operations, addresses are latched on the rising edge of ADV#, or on the next valid CLK edge with ADV# low, whichever occurs first. In asynchronous mode, the address is latched when ADV# going high or continuously flows through if ADV# is held low. WARNING: Designs not using ADV# must tie it to VSS to allow addresses to flow through.
CE#	Input	CHIP ENABLE: Active low input. CE# low selects the associated flash memory die. When asserted, flash internal control logic, input buffers, decoders, and sense amplifiers are active. When deasserted, the associated flash die is deselected, power is reduced to standby levels, data and WAIT outputs are placed in high-Z state. WARNING: Chip enable must be driven high when device is not in use.
CLK	Input	CLOCK: Synchronizes the device with the system's bus frequency in synchronous-read mode. During synchronous read operations, addresses are latched on the rising edge of ADV#, or on the next valid CLK edge with ADV# low, whichever occurs first. WARNING: Designs not using CLK for synchronous read mode must tie it to VCCQ or VSS.
OE#	Input	OUTPUT ENABLE: Active low input. OE# low enables the device's output data buffers during read cycles. OE# high places the data outputs and WAIT in High-Z.
RST#	Input	RESET: Active low input. RST# resets internal automation and inhibits write operations. This provides data protection during power transitions. RST# high enables normal operation. Exit from reset places the device in asynchronous read array mode.
WAIT	Output	WAIT: Indicates data valid in synchronous array or non-array burst reads. Read Configuration Register bit 10 (RCR.10, WT) determines its polarity when asserted. WAIT's active output is V_{OL} or V_{OH} when CE# and OE# are V_{IL} . WAIT is high-Z if CE# or OE# is V_{IH} . <ul style="list-style-type: none"> In synchronous array or non-array read modes, WAIT indicates invalid data when asserted and valid data when deasserted. In asynchronous page mode, and all write modes, WAIT is deasserted.
WE#	Input	WRITE ENABLE: Active low input. WE# controls writes to the device. Address and data are latched on the rising edge of WE#.
WP#	Input	WRITE PROTECT: Active low input. WP# low enables the lock-down mechanism. Blocks in lock-down cannot be unlocked with the Unlock command. WP# high overrides the lock-down function enabling blocks to be erased or programmed using software commands.
VPP	Power/ Input	ERASE AND PROGRAM POWER: A valid voltage on this pin allows erasing or programming. Memory contents cannot be altered when $V_{pp} \leq V_{ppLK}$. Block erase and program at invalid V_{pp} voltages should not be attempted. Set $V_{pp} = V_{ppl}$ for in-system program and erase operations. To accommodate resistor or diode drops from the system supply, the V_{IH} level of V_{pp} can be as low as V_{ppl} min. V_{pp} must remain above V_{ppl} min to perform in-system flash modification. VPP may be 0 V during read operations. V_{ppH} can be applied to main blocks for 1000 cycles maximum and to parameter blocks for 2500 cycles. VPP can be connected to 9 V for a cumulative total not to exceed 80 hours. Extended use of this pin at 9 V may reduce block cycling capability.
VCC	Power	DEVICE CORE POWER SUPPLY: Core (logic) source voltage. Writes to the flash array are inhibited when $V_{CC} \leq V_{LKO}$. Operations at invalid V_{CC} voltages should not be attempted.
VCCQ	Power	OUTPUT POWER SUPPLY: Output-driver source voltage.
VSS	Power	GROUND: Connect to system ground. Do not float any VSS connection.

Table 5: TSOP and Easy BGA Signal Descriptions (Sheet 2 of 2)

Symbol	Type	Name and Function
RFU	—	RESERVED FOR FUTURE USE: Reserved by Numonyx for future device functionality and enhancement. These should be treated in the same way as a Do Not Use (DU) signal.
DU	—	DO NOT USE: Do not connect to any other signal, or power supply; must be left floating.
NC	—	NO CONNECT: No internal connection; can be driven or floated.

Table 6: QUAD+ SCSP Signal Descriptions (Sheet 1 of 2)

Symbol	Type	Name and Function
A[MAX:0]	Input	ADDRESS INPUTS: Device address inputs. 256-Mbit: A[23:0]; 512-Mbit: A[24:0]. <i>Note:</i> The virtual selection of the 256-Mbit "Top parameter" die in the dual-die 512-Mbit configuration is accomplished by setting A24 high (V_{IH}).
DQ[15:0]	Input/Output	DATA INPUT/OUTPUTS: Inputs data and commands during write cycles; outputs data during memory, Status Register, Protection Register, and Read Configuration Register reads. Data balls float when the CE# or OE# are deasserted. Data is internally latched during writes.
ADV#	Input	ADDRESS VALID: Active low input. During synchronous read operations, addresses are latched on the rising edge of ADV#, or on the next valid CLK edge with ADV# low, whichever occurs first. In asynchronous mode, the address is latched when ADV# going high or continuously flows through if ADV# is held low. WARNING: Designs not using ADV# must tie it to VSS to allow addresses to flow through.
F1-CE#	Input	Flash CHIP ENABLE: Active low input. CE# low selects the associated flash memory die. When asserted, flash internal control logic, input buffers, decoders, and sense amplifiers are active. When deasserted, the associated flash die is deselected, power is reduced to standby levels, data and WAIT outputs are placed in high-Z state. WARNING: Chip enable must be driven high when device is not in use.
CLK	Input	CLOCK: Synchronizes the device with the system's bus frequency in synchronous-read mode. During synchronous read operations, addresses are latched on the rising edge of ADV#, or on the next valid CLK edge with ADV# low, whichever occurs first. WARNING: Designs not using CLK for synchronous read mode must tie it to VCCQ or VSS.
F1-OE#	Input	OUTPUT ENABLE: Active low input. OE# low enables the device's output data buffers during read cycles. OE# high places the data outputs and WAIT in High-Z.
RST#	Input	RESET: Active low input. RST# resets internal automation and inhibits write operations. This provides data protection during power transitions. RST# high enables normal operation. Exit from reset places the device in asynchronous read array mode.
WAIT	Output	WAIT: Indicates data valid in synchronous array or non-array burst reads. Read Configuration Register bit 10 (RCR.10, WT) determines its polarity when asserted. WAIT's active output is V_{OL} or V_{OH} when CE# and OE# are V_{IL} . WAIT is high-Z if CE# or OE# is V_{IH} . <ul style="list-style-type: none"> In synchronous array or non-array read modes, WAIT indicates invalid data when asserted and valid data when deasserted. In asynchronous page mode, and all write modes, WAIT is deasserted.
WE#	Input	WRITE ENABLE: Active low input. WE# controls writes to the device. Address and data are latched on the rising edge of WE#.
WP#	Input	WRITE PROTECT: Active low input. WP# low enables the lock-down mechanism. Blocks in lock-down cannot be unlocked with the Unlock command. WP# high overrides the lock-down function enabling blocks to be erased or programmed using software commands.
VPP	Power/ Input	ERASE AND PROGRAM POWER: A valid voltage on this pin allows erasing or programming. Memory contents cannot be altered when $V_{PP} \leq V_{PPLK}$. Block erase and program at invalid V_{PP} voltages should not be attempted. Set $V_{PP} = V_{PPL}$ for in-system program and erase operations. To accommodate resistor or diode drops from the system supply, the V_{IH} level of V_{PP} can be as low as V_{PPL} min. V_{PP} must remain above V_{PPL} min to perform in-system flash modification. V_{PP} may be 0 V during read operations. V_{PPH} can be applied to main blocks for 1000 cycles maximum and to parameter blocks for 2500 cycles. V_{PP} can be connected to 9 V for a cumulative total not to exceed 80 hours. Extended use of this pin at 9 V may reduce block cycling capability.

Table 6: QUAD+ SCSP Signal Descriptions (Sheet 2 of 2)

Symbol	Type	Name and Function
VCC	Power	DEVICE CORE POWER SUPPLY: Core (logic) source voltage. Writes to the flash array are inhibited when $V_{CC} \leq V_{LKO}$. Operations at invalid V_{CC} voltages should not be attempted.
VCCQ	Power	OUTPUT POWER SUPPLY: Output-driver source voltage.
VSS	Power	GROUND: Connect to system ground. Do not float any VSS connection.
RFU	—	RESERVED FOR FUTURE USE: Reserved by Numonyx for future device functionality and enhancement. These should be treated in the same way as a Do Not Use (DU) signal.
DU	—	DO NOT USE: Do not connect to any other signal, or power supply; must be left floating.
NC	—	NO CONNECT: No internal connection; can be driven or floated.

4.1 Dual-Die Configurations

Figure 9: 512-Mbit Easy BGA Block Diagram

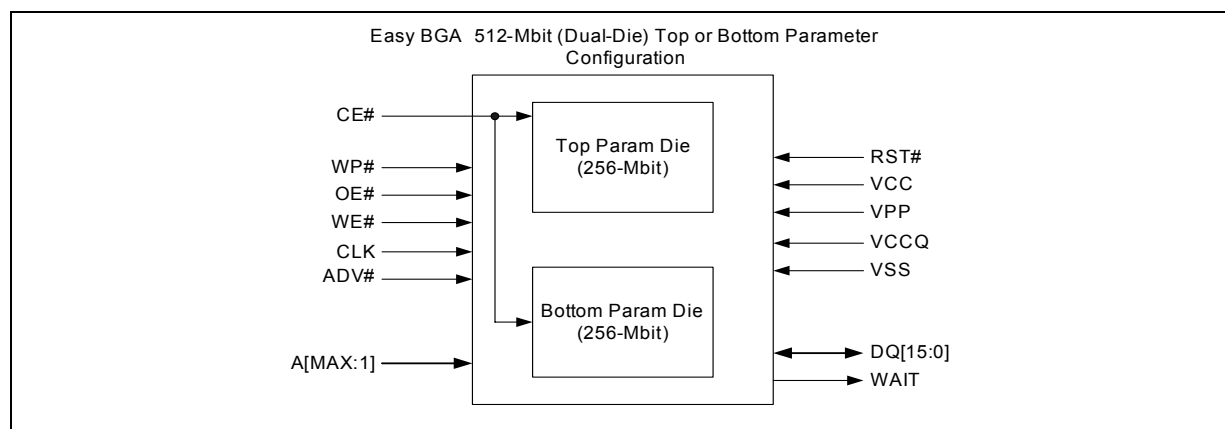
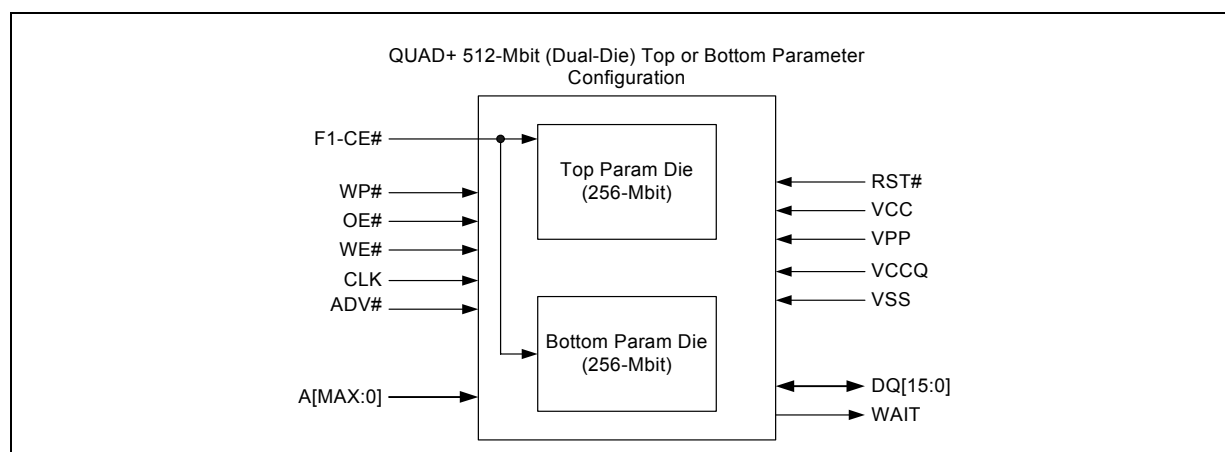

Figure 10: 512-Mbit QUAD+ SCSP Block Diagram



Note: $A_{max} = V_{IH}$ selects the Top parameter Die; $A_{max} = V_{IL}$ selects the Bottom Parameter Die.

5.0 Bus Operations

CE# low and RST# high enable device read operations. The device internally decodes upper address inputs to determine the accessed block. ADV# low opens the internal address latches. OE# low activates the outputs and gates selected data onto the I/O bus.

In asynchronous mode, the address is latched when ADV# goes high or continuously flows through if ADV# is held low. In synchronous mode, the address is latched by the first of either the rising ADV# edge or the next valid CLK edge with ADV# low (WE# and RST# must be V_{IH} ; CE# must be V_{IL}).

Bus cycles to/from the P30-65nm device conform to standard microprocessor bus operations. [Table 7](#) summarizes the bus operations and the logic levels that must be applied to the device control signal inputs.

Table 7: Bus Operations Summary

Bus Operation		RST#	CLK	ADV#	CE#	OE#	WE#	WAIT	DQ[15:0]	Notes
Read	Asynchronous	V_{IH}	X	L	L	L	H	Deasserted	Output	
	Synchronous	V_{IH}	Running	L	L	L	H	Driven	Output	
Write		V_{IH}	X	L	L	H	L	High-Z	Input	1
Output Disable		V_{IH}	X	X	L	H	H	High-Z	High-Z	2
Standby		V_{IH}	X	X	H	X	X	High-Z	High-Z	2
Reset		V_{IL}	X	X	X	X	X	High-Z	High-Z	2,3

Notes:

1. Refer to the [Table 9, "Command Bus Cycles" on page 23](#) for valid DQ[15:0] during a write operation.
2. X = Don't Care (H or L).
3. RST# must be at $V_{SS} \pm 0.2 V$ to meet the maximum specified power-down current.

5.1 Reads

To perform a read operation, RST# and WE# must be deasserted while CE# and OE# are asserted. CE# is the device-select control. When asserted, it enables the flash memory device. OE# is the data-output control. When asserted, the addressed flash memory data is driven onto the I/O bus.

5.2 Writes

To perform a write operation, both CE# and WE# are asserted while RST# and OE# are deasserted. During a write operation, address and data are latched on the rising edge of WE# or CE#, whichever occurs first. [Table 9, "Command Bus Cycles" on page 23](#) shows the bus cycle sequence for each of the supported device commands, while [Table 8, "Command Codes and Definitions" on page 21](#) describes each command. See [Section 15.0, "AC Characteristics" on page 53](#) for signal-timing details.

Note: Write operations with invalid V_{CC} and/or V_{PP} voltages can produce spurious results and should not be attempted.

5.3 Output Disable

When OE# is deasserted, device outputs DQ[15:0] are disabled and placed in a high-impedance (High-Z) state, WAIT is also placed in High-Z.

5.4 Standby

When CE# is deasserted the device is deselected and placed in standby, substantially reducing power consumption. In standby, the data outputs are placed in High-Z, independent of the level placed on OE#. Standby current, I_{CCS} , is the average current measured over any 5 ms time interval, 5 μ s after CE# is deasserted. During standby, average current is measured over the same time interval 5 μ s after CE# is deasserted.

When the device is deselected (while CE# is deasserted) during a program or erase operation, it continues to consume active power until the program or erase operation is completed.

5.5 Reset

As with any automated device, it is important to assert RST# when the system is reset. When the system comes out of reset, the system processor attempts to read from the flash memory if it is the system boot device. If a CPU reset occurs with no flash memory reset, improper CPU initialization may occur because the flash memory may be providing status information rather than array data. Flash memory devices from Numonyx allow proper CPU initialization following a system reset through the use of the RST# input. RST# should be controlled by the same low-true reset signal that resets the system CPU.

After initial power-up or reset, the device defaults to asynchronous Read Array mode, and the Status Register is set to 0x80. Asserting RST# de-energizes all internal circuits, and places the output drivers in High-Z. When RST# is asserted, the device shuts down the operation in progress, a process which takes a minimum amount of time to complete. When RST# has been deasserted, the device is reset to asynchronous Read Array state.

Note: If RST# is asserted during a program or erase operation, the operation is terminated and the memory contents at the aborted location (for a program) or block (for an erase) are no longer valid, because the data may have been only partially written or erased.

When returning from a reset (RST# deasserted), a minimum wait is required before the initial read access outputs valid data. Also, a minimum delay is required after a reset before a write cycle can be initiated. After this wake-up interval passes, normal operation is restored. See [Section 15.0, "AC Characteristics" on page 53](#) for details about signal-timing.

6.0 Command Set

6.1 Device Command Codes

The system CPU provides control of all in-system read, write, and erase operations of the device via the system bus. The on-chip Write State Machine (WSM) manages all block-erase and word-program algorithms.

Device commands are written to the Command User Interface (CUI) to control all flash memory device operations. The CUI does not occupy an addressable memory location; it is the mechanism through which the flash device is controlled.

Table 8: Command Codes and Definitions (Sheet 1 of 2)

Mode	Code	Device Mode	Description
Read	0xFF	Read Array	Places the device in Read Array mode. Array data is output on DQ[15:0].
	0x70	Read Status Register	Places the device in Read Status Register mode. The device enters this mode after a program or erase command is issued. Status Register data is output on DQ[7:0].
	0x90	Read Device ID or Read Configuration Register (RCR)	Places device in Read Device Identifier mode. Subsequent reads output manufacturer/device codes, Configuration Register data, Block Lock status, or Protection Register data on DQ[15:0].
	0x98	Read CFI	Places the device in Read CFI mode. Subsequent reads output Common Flash Interface information on DQ[7:0].
	0x50	Clear Status Register	The WSM can only set Status Register error bits. The Clear Status Register command is used to clear the SR error bits.
Write	0x40	Word Program Setup	First cycle of a 2-cycle programming command; prepares the CUI for a write operation. On the next write cycle, the address and data are latched and the WSM executes the programming algorithm at the addressed location. During program operations, the device responds only to Read Status Register and Program Suspend commands. CE# or OE# must be toggled to update the Status Register in asynchronous read. CE# or ADV# must be toggled to update the Status Register Data for synchronous Non-array reads. The Read Array command must be issued to read array data after programming has finished.
	0xE8	Buffered Program	This command loads a variable number of words up to the buffer size of 512 words onto the program buffer.
	0xD0	Buffered Program Confirm	The confirm command is issued after the data streaming for writing into the buffer is done. This instructs the WSM to perform the Buffered Program algorithm, writing the data from the buffer to the flash memory array.
	0x80	BEFP Setup	First cycle of a 2-cycle command; initiates Buffered Enhanced Factory Program mode (BEFP). The CUI then waits for the BEFP Confirm command, 0xD0, that initiates the BEFP algorithm. All other commands are ignored when BEFP mode begins.
	0xD0	BEFP Confirm	If the previous command was BEFP Setup (0x80), the CUI latches the address and data, and prepares the device for BEFP mode.
Erase	0x20	Block Erase Setup	First cycle of a 2-cycle command; prepares the CUI for a block-erase operation. The WSM performs the erase algorithm on the block addressed by the Erase Confirm command. If the next command <i>is not</i> the Erase Confirm (0xD0) command, the CUI sets Status Register bits SR.4 and SR.5, and places the device in read status register mode.
	0xD0	Block Erase Confirm	If the first command was Block Erase Setup (0x20), the CUI latches the address and data, and the WSM erases the addressed block. During block-erase operations, the device responds only to Read Status Register and Erase Suspend commands. CE# or OE# must be toggled to update the Status Register in asynchronous read. CE# or ADV# must be toggled to update the Status Register Data for synchronous Non-array reads.

Table 8: Command Codes and Definitions (Sheet 2 of 2)

Mode	Code	Device Mode	Description
Suspend	0xB0	Program or Erase Suspend	This command issued to any device address initiates a suspend of the currently-executing program or block erase operation. The Status Register indicates successful suspend operation by setting either SR.2 (program suspended) or SR.6 (erase suspended), along with SR.7 (ready). The Write State Machine remains in the suspend mode regardless of control signal states (except for RST# asserted).
	0xD0	Suspend Resume	This command issued to any device address resumes the suspended program or block-erase operation.
Block Locking/ Unlocking	0x60	Block lock Setup	First cycle of a 2-cycle command; prepares the CUI for block lock configuration changes. If the next command is not Block Lock (0x01), Block Unlock (0xD0), or Block Lock-Down (0x2F), the CUI sets Status Register bits SR.5 and SR.4, indicating a command sequence error.
	0x01	Block lock	If the previous command was Block Lock Setup (0x60), the addressed block is locked.
	0xD0	Block Unlock	If the previous command was Block Lock Setup (0x60), the addressed block is unlocked. If the addressed block is in a lock-down state, the operation has no effect.
	0x2F	Block Lock-Down	If the previous command was Block Lock Setup (0x60), the addressed block is locked down.
Protection	0x60	Block lock Setup	First cycle of a 2-cycle command; prepares the CUI for block lock configuration changes. If the next command is not Block Lock (0x01), Block Unlock (0xD0), or Block Lock-Down (0x2F), the CUI sets Status Register bits SR.5 and SR.4, indicating a command sequence error.
	0x01	Block lock	If the previous command was Block Lock Setup (0x60), the addressed block is locked.
	0xD0	Block Unlock	If the previous command was Block Lock Setup (0x60), the addressed block is unlocked. If the addressed block is in a lock-down state, the operation has no effect.
	0x2F	Block Lock-Down	If the previous command was Block Lock Setup (0x60), the addressed block is locked down.
	0xC0	OTP Register or Lock Register program setup	First cycle of a 2-cycle command; prepares the device for a OTP register or Lock Register program operation. The second cycle latches the register address and data, and starts the programming algorithm to program data the the OTP array.
Configuration	0x60	Read Configuration Register Setup	First cycle of a 2-cycle command; prepares the CUI for device read configuration. If the Set Read Configuration Register command (0x03) is not the next command, the CUI sets Status Register bits SR.4 and SR.5, indicating a command sequence error.
	0x03	Read Configuration Register	If the previous command was Read Configuration Register Setup (0x60), the CUI latches the address and writes A[16:1] to the Read Configuration Register for Easy BGA and TSOP, A[15:0] for QUAD+. Following a Configure Read Configuration Register command, subsequent read operations access array data.
Blank Check	0xBC	Block Blank Check	First cycle of a 2-cycle command; initiates the Blank Check operation on a main block.
	0xD0	Block Blank Check Confirm	Second cycle of blank check command sequence; it latches the block address and executes blank check on the main array block.
EFI ⁽¹⁾	0xEB	Extended Function Interface command	First cycle of a multiple-cycle command; initiate operation using extended function interface. The second cycle is a Sub-Op-Code, the data written on third cycle is one less than the word count; the allowable value on this cycle are 0 through 511. The subsequent cycles load data words into the program buffer at a specified address until word count is achieved.

6.2 Device Command Bus Cycles

Device operations are initiated by writing specific device commands to the Command User Interface (CUI). Several commands are used to modify array data including Word Program and Block Erase commands. Writing either command to the CUI initiates a sequence of internally-timed functions that culminate in the completion of the requested task. However, the operation can be aborted by either asserting RST# or by issuing an appropriate suspend command.

Table 9: Command Bus Cycles (Sheet 1 of 2)

Mode	Command	Bus Cycles	First Bus Cycle			Second Bus Cycle		
			Oper	Addr ⁽¹⁾	Data ⁽²⁾	Oper	Addr ⁽¹⁾	Data ⁽²⁾
Read	Read Array	1	Write	DnA	0xFF	-	-	-
	Read Device Identifier	≥ 2	Write	DnA	0x90	Read	DBA + IA	ID
	Read CFI	≥ 2	Write	DnA	0x98	Read	DBA + CFI-A	CFI-D
	Read Status Register	2	Write	DnA	0x70	Read	DnA	SRD
	Clear Status Register	1	Write	DnA	0x50	-	-	-
Program	Word Program	2	Write	WA	0x40	Write	WA	WD
	Buffered Program ⁽³⁾	> 2	Write	WA	0xE8	Write	WA	N - 1
	Buffered Enhanced Factory Program (BEFP) ⁽⁴⁾	> 2	Write	WA	0x80	Write	WA	0xD0
Erase	Block Erase	2	Write	BA	0x20	Write	BA	0xD0
Suspend	Program/Erase Suspend	1	Write	DnA	0xB0	-	-	-
	Program/Erase Resume	1	Write	DnA	0xD0	-	-	-
Block Locking/Unlocking	Block Lock	2	Write	BA	0x60	Write	BA	0x01
	Block Unlock	2	Write	BA	0x60	Write	BA	0xD0
	Block Lock-down	2	Write	BA	0x60	Write	BA	0x2F
Protection	Block Lock	2	Write	BA	0x60	Write	BA	0x01
	Block Unlock	2	Write	BA	0x60	Write	BA	0xD0
	Block Lock-down	2	Write	BA	0x60	Write	BA	0x2F
	Program OTP register	2	Write	PRA	0xC0	Write	OTP-RA	OTP-D
	Program Lock Register	2	Write	LRA	0xC0	Write	LRA	LRD
Configuration	Configure Read Configuration Register	2	Write	RCD	0x60	Write	RCD	0x03

Table 9: Command Bus Cycles (Sheet 2 of 2)

Mode	Command	Bus Cycles	First Bus Cycle			Second Bus Cycle		
			Oper	Addr ⁽¹⁾	Data ⁽²⁾	Oper	Addr ⁽¹⁾	Data ⁽²⁾
Blank Check	Block Blank Check	2	Write	BA	0xBC	Write	BA	D0
EFI	Extended Function Interface command ⁽⁵⁾	>2	Write	WA	0xEB	Write	WA	Sub-Op code

Notes:

- First command cycle address should be the same as the operation's target address.
 DBA = Device Base Address (NOTE: needed for dual-die 512 Mb device)
 DnA = Address within the device.
 IA = Identification code address offset.
 CFI-A = Read CFI address offset.
 WA = Word address of memory location to be written.
 BA = Address within the block.
 OTP-RA = Protection Register address.
 LRA = Lock Register address.
 RCD = Read Configuration Register data on A[16:1] for Easy BGA and TSOP, A[15:0] for QUAD+ package.
- ID = Identifier data.
 CFI-D = CFI data on DQ[15:0].
 SRD = Status Register data.
 WD = Word data.
 N = Word count of data to be loaded into the write buffer.
 OTP-D = Protection Register data.
 LRD = Lock Register data.
- The second cycle of the Buffered Program Command is the word count of the data to be loaded into the write buffer. This is followed by up to 512 words of data. Then the confirm command (0xD0) is issued, triggering the array programming operation.
- The confirm command (0xD0) is followed by the buffer data.
- The second cycle is a Sub-Op-Code, the data written on third cycle is N-1; $1 \leq N \leq 512$. The subsequent cycles load data words into the program buffer at a specified address until word count is achieved, after the data words are loaded, the final cycle is the confirm cycle 0xD0).

7.0 Read Operation

The device supports two read modes: asynchronous page mode and synchronous burst mode. Asynchronous page mode is the default read mode after device power-up or a reset. The Read Configuration Register must be configured to enable synchronous burst reads of the flash memory array (see [Section 11.2, "Read Configuration Register" on page 39](#)).

The device can be in any of four read states: Read Array, Read Identifier, Read Status or Read CFI. Upon power-up, or after a reset, the device defaults to Read Array. To change the read state, the appropriate read command must be written to the device (see [Section 6.0, "Command Set" on page 21](#)).

7.1 Asynchronous Page-Mode Read

Following a device power-up or reset, asynchronous page mode is the default read mode and the device is set to Read Array. However, to perform array reads after any other device operation (e.g. write operation), the Read Array command must be issued in order to read from the flash memory array.

Asynchronous page-mode reads can only be performed when Read Configuration Register bit RCR.15 is set (see [Section 11.2, "Read Configuration Register" on page 39](#)).

To perform an asynchronous page-mode read, an address is driven onto the Address bus, and CE# and ADV# are asserted. WE# and RST# must already have been deasserted. WAIT is deasserted during asynchronous page mode. ADV# can be driven high to latch the address, or it must be held low throughout the read cycle. CLK is not used for asynchronous page-mode reads, and is ignored. If only asynchronous reads are to be performed, CLK should be tied to a valid V_{IH} level, WAIT signal can be floated and ADV# must be tied to ground. Array data is driven onto DQ[15:0] after an initial access time t_{AVQV} delay. (see [Section 15.0, "AC Characteristics" on page 53](#)).

In asynchronous page mode, sixteen data words are "sensed" simultaneously from the flash memory array and loaded into an internal page buffer. The buffer word corresponding to the initial address on the Address bus is driven onto DQ[15:0] after the initial access delay. The lowest four address bits determine which word of the 16-word page is output from the data buffer at any given time.

7.2 Synchronous Burst-Mode Read

To perform a synchronous burst-read, an initial address is driven onto the Address bus, and CE# and ADV# are asserted. WE# and RST# must already have been deasserted. ADV# is asserted, and then deasserted to latch the address. Alternately, ADV# can remain asserted throughout the burst access, in which case the address is latched on the next valid CLK edge while ADV# is asserted.

During synchronous array and non-array read modes, the first word is output from the data buffer on the next valid CLK edge after the initial access latency delay (see [Section 11.2.2, "Latency Count" on page 40](#)). Subsequent data is output on valid CLK edges following a minimum delay. However, for a synchronous non-array read, the same word of data will be output on successive clock edges until the burst length requirements are satisfied. Refer to the following waveforms for more detailed information:

- [Figure 24, "Synchronous Single-Word Array or Non-array Read Timing" on page 57](#)
- [Figure 25, "Continuous Burst Read, Showing An Output Delay Timing" on page 58](#)
- [Figure 26, "Synchronous Burst-Mode Four-Word Read Timing" on page 58](#)

7.3 Read Device Identifier

The Read Device Identifier command instructs the device to output manufacturer code, device identifier code, block-lock status, protection register data, or configuration register data.

Table 10: Device Identifier Information

Item	Address ⁽¹⁾	Data
Manufacturer Code	0x00	0x89h
Device ID Code	0x01	ID (see Table 11, "Device ID codes")
Block Lock Configuration: <ul style="list-style-type: none"> • Block Is Unlocked • Block Is Locked • Block Is not Locked-Down • Block Is Locked-Down 	BBA ⁽¹⁾ + 0x02	Lock Bit: DQ ₀ = 0b0 DQ ₀ = 0b1 DQ ₁ = 0b0 DQ ₁ = 0b1
Read Configuration Register	0x05	RCR Contents
General Purpose Register ⁽³⁾	DBA ⁽²⁾ + 0x07	GPR Data
Lock Register 0	0x80	PR-LK0 data
64-bit Factory-Programmed OTP Register	0x81–0x84	Factory OTP Register Data
64-bit User-Programmable OTP Register	0x85–0x88	User OTP Register Data
Lock Register 1	0x89	PR-LK1 OTP register lock data
128-bit User-Programmable Protection Registers	0x8A–0x109	OTP Register Data

Notes:

1. BBA = Block Base Address.
2. DBA = Device base Address, Numonyx reserves other configuration address locations.
3. The GPR is used as read out register for Extended Function interface command.

Table 11: Device ID codes

ID Code Type	Device Density	Device Identifier Codes	
		-T (Top Parameter)	-B (Bottom Parameter)
Device Code	256-Mbit	8919	891C

Note: The 512-Mbit devices do not have a unique Device ID associated with them. Each die within the stack can be identified by either of the 256-Mbit Device ID codes depending on its parameter option.

7.4 Read CFI

The Read CFI command instructs the device to output Common Flash Interface (CFI) data when read. See [Section 6.0, "Command Set" on page 21](#) for details on issuing the Read CFI command. [Appendix A, "Common Flash Interface Tables" on page 66](#) shows CFI information and address offsets within the CFI database.

8.0 Program Operation

The device supports three programming methods: Word Programming (40h or 10h), Buffered Programming (E8h, D0h), and Buffered Enhanced Factory Programming (80h, D0h). See [Section 5.0, "Bus Operations" on page 19](#) for details on the various programming commands issued to the device. The following sections describe device programming in detail.

Successful programming requires the addressed block to be unlocked. If the block is locked down, WP# must be deasserted and the block must be unlocked before attempting to program the block. Attempting to program a locked block causes a program error (SR.4 and SR.1 set) and termination of the operation. See [Section 10.0, "Security Modes" on page 35](#) for details on locking and unlocking blocks.

8.1 Word Programming

Word programming operations are initiated by writing the Word Program Setup command to the device (see [Section 5.0, "Bus Operations" on page 19](#)). This is followed by a second write to the device with the address and data to be programmed. The device outputs Status Register data when read. See [Figure 35, "Word Program Flowchart" on page 78](#). V_{pp} must be above V_{PPLK} , and within the specified V_{PPL} min/max values.

During programming, the Write State Machine (WSM) executes a sequence of internally-timed events that program the desired data bits at the addressed location, and verifies that the bits are sufficiently programmed. Programming the flash memory array changes "ones" to "zeros". Memory array bits that are zeros can be changed to ones only by erasing the block (see [Section 9.0, "Erase Operations" on page 33](#)).

The Status Register can be examined for programming progress and errors by reading at any address. The device remains in the Read Status Register state until another command is written to the device.

Status Register bit SR.7 indicates the programming status while the sequence executes. Commands that can be issued to the device during programming are Program Suspend, Read Status Register, Read Device Identifier, Read CFI, and Read Array (this returns unknown data).

When programming has finished, Status Register bit SR.4 (when set) indicates a programming failure. If SR.3 is set, the WSM could not perform the word programming operation because V_{pp} was outside of its acceptable limits. If SR.1 is set, the word programming operation attempted to program a locked block, causing the operation to abort.

Before issuing a new command, the Status Register contents should be examined and then cleared using the Clear Status Register command. Any valid command can follow, when word programming has completed.

8.2 Buffered Programming

The device features a 512-word buffer to enable optimum programming performance. For Buffered Programming, data is first written to an on-chip write buffer. Then the buffer data is programmed into the flash memory array in buffer-size increments. This can improve system programming performance significantly over non-buffered programming.

When the Buffered Programming Setup command is issued (see [Section 6.0, "Command Set" on page 21](#)), Status Register information is updated and reflects the availability of the buffer. SR.7 indicates buffer availability: if set, the buffer is available; if cleared, the buffer is not available.

Note: The device default state is to output SR data after the Buffer Programming Setup Command. CE# and OE# low drive device to update Status Register. It is not allowed to issue 70h to read SR data after E8h command otherwise 70h would be counted as Word Count.

On the next write, a word count is written to the device at the buffer address. This tells the device how many data words will be written to the buffer, up to the maximum size of the buffer.

On the next write, a device start address is given along with the first data to be written to the flash memory array. Subsequent writes provide additional device addresses and data. All data addresses must lie within the start address plus the word count. Optimum programming performance and lower power usage are obtained by aligning the starting address at the beginning of a 512-word boundary (A[9:1] = 0x00 for Easy BGA and TSOP, A[8:0] for QUAD+ package). The maximum buffer size would be 256-word if the misaligned address range is crossing a 512-word boundary during programming.

After the last data is written to the buffer, the Buffered Programming Confirm command must be issued to the original block address. The WSM begins to program buffer contents to the flash memory array. If a command other than the Buffered Programming Confirm command is written to the device, a command sequence error occurs and Status Register bits SR[7,5,4] are set. If an error occurs while writing to the array, the device stops programming, and Status Register bits SR[7,4] are set, indicating a programming failure.

When Buffered Programming has completed, additional buffer writes can be initiated by issuing another Buffered Programming Setup command and repeating the buffered program sequence. Buffered programming may be performed with $V_{pp} = V_{ppl}$ or V_{pph} (see [Section 13.2, "Operating Conditions" on page 50](#) for limitations when operating the device with $V_{pp} = V_{pph}$).

If an attempt is made to program past an erase-block boundary using the Buffered Program command, the device aborts the operation. This generates a command sequence error, and Status Register bits SR[5,4] are set.

If Buffered programming is attempted while V_{pp} is at or below V_{pplk} , Status Register bits SR[4,3] are set. If any errors are detected that have set Status Register bits, the Status Register should be cleared using the Clear Status Register command.

8.3 Buffered Enhanced Factory Programming

Buffered Enhanced Factory Programming (BEFP) speeds up Multi-Level Cell (MLC) flash programming. The enhanced programming algorithm used in BEFP eliminates traditional programming elements that drive up overhead in device programmer systems.

BEFP consists of three phases: Setup, Program/Verify, and Exit (see [Figure 38, "BEFP Flowchart" on page 81](#)). It uses a write buffer to spread MLC program performance across 512 data words. Verification occurs in the same phase as programming to accurately program the flash memory cell to the correct bit state.

A single two-cycle command sequence programs the entire block of data. This enhancement eliminates three write cycles per buffer: two commands and the word count for each set of 512 data words. Host programmer bus cycles fill the device's write buffer followed by a status check. SR.0 indicates when data from the buffer has been programmed into sequential flash memory array locations.

Following the buffer-to-flash array programming sequence, the Write State Machine (WSM) increments internal addressing to automatically select the next 512-word array boundary. This aspect of BEFP saves host programming equipment the address-bus setup overhead.

With adequate continuity testing, programming equipment can rely on the WSM's internal verification to ensure that the device has programmed properly. This eliminates the external post-program verification and its associated overhead.

8.3.1 BEFP Requirements and Considerations

Table 12: BEFP Requirements

Parameter/Issue	Requirement	Notes
Case Temperature	$T_C = 30^{\circ}\text{C} \pm 10^{\circ}\text{C}$	
V _{CC}	Nominal V _{CC}	
V _{PP}	Driven to V _{PPH}	
Setup and Confirm	Target block must be unlocked before issuing the BEFP Setup and Confirm commands	
Programming	The first-word address (WA0) of the block to be programmed must be held constant from the setup phase through all data streaming into the target block, until transition to the exit phase is desired	
Buffer Alignment	WA0 must align with the start of an array buffer boundary	1

Note: Word buffer boundaries in the array are determined by A[9:1] for Easy BGA and TSOP, A[8:0] for QUAD+ package (0x000 through 0x1FF). The alignment start point is A[9:1] = 0x000 for Easy BGA and TSOP, A[8:0] = 0x000 for QUAD+ package.

Table 13: BEFP Considerations

Parameter/Issue	Requirement	Notes
Cycling	For optimum performance, cycling must be limited below 50 erase cycles per block.	1
Programming blocks	BEFP programs one block at a time; all buffer data must fall within a single block	2
Suspend	BEFP cannot be suspended	
Programming the flash memory array	Programming to the flash memory array can occur only when the buffer is full.	3

Note:

- Some degradation in performance may occur if this limit is exceeded, but the internal algorithm continues to work properly.
- If the internal address counter increments beyond the block's maximum address, addressing wraps around to the beginning of the block.
- If the number of words is less than 512, remaining locations must be filled with 0xFFFF.

8.3.2 BEFP Setup Phase

After receiving the BEFP Setup and Confirm command sequence, Status Register bit SR.7 (Ready) is cleared, indicating that the WSM is busy with BEFP algorithm startup. A delay before checking SR.7 is required to allow the WSM enough time to perform all of

its setups and checks (Block-Lock status, V_{pp} level, etc.). If an error is detected, SR.4 is set and BEFP operation terminates. If the block was found to be locked, SR.1 is also set. SR.3 is set if the error occurred due to an incorrect V_{pp} level.

Note: Reading from the device after the BEFP Setup and Confirm command sequence outputs Status Register data. Do not issue the Read Status Register command; it will be interpreted as data to be loaded into the buffer.

8.3.3 BEFP Program/Verify Phase

After the BEFP Setup Phase has completed, the host programming system must check SR[7,0] to determine the availability of the write buffer for data streaming. SR.7 cleared indicates the device is busy and the BEFP program/verify phase is activated. SR.0 indicates the write buffer is available.

Two basic sequences repeat in this phase: loading of the write buffer, followed by buffer data programming to the array. For BEFP, the count value for buffer loading is always the maximum buffer size of 512 words. During the buffer-loading sequence, data is stored to sequential buffer locations starting at address 0x00. Programming of the buffer contents to the flash memory array starts as soon as the buffer is full. If the number of words is less than 512, the remaining buffer locations must be filled with 0xFFFF.

Caution: **The buffer must be completely filled for programming to occur. Supplying an address outside of the current block's range during a buffer-fill sequence causes the algorithm to exit immediately. Any data previously loaded into the buffer during the fill cycle is not programmed into the array.**

The starting address for data entry must be buffer size aligned, if not the BEFP algorithm will be aborted and the program fails and (SR.4) flag will be set.

Data words from the write buffer are directed to sequential memory locations in the flash memory array; programming continues from where the previous buffer sequence ended. The host programming system must poll SR.0 to determine when the buffer program sequence completes. SR.0 cleared indicates that all buffer data has been transferred to the flash array; SR.0 set indicates that the buffer is not available yet for the next fill cycle. The host system may check full status for errors at any time, but it is only necessary on a block basis after BEFP exit. After the buffer fill cycle, no write cycles should be issued to the device until SR.0 = 0 and the device is ready for the next buffer fill.

Note: Any spurious writes are ignored after a buffer fill operation and when internal program is proceeding.

The host programming system continues the BEFP algorithm by providing the next group of data words to be written to the buffer. Alternatively, it can terminate this phase by changing the block address to one outside of the current block's range.

The Program/Verify phase concludes when the programmer writes to a different block address; data supplied must be 0xFFFF. Upon Program/Verify phase completion, the device enters the BEFP Exit phase.

8.3.4 BEFP Exit Phase

When SR.7 is set, the device has returned to normal operating conditions. A full status check should be performed at this time to ensure the entire block programmed successfully. When exiting the BEFP algorithm with a block address change, the read mode will not change. After BEFP exit, any valid command can be issued to the device.

8.4 Program Suspend

Issuing the Program Suspend command while programming suspends the programming operation. This allows data to be accessed from the device other than the one being programmed. The Program Suspend command can be issued to any device address. A program operation can be suspended to perform reads only. Additionally, a program operation that is running during an erase suspend can be suspended to perform a read operation (see [Figure 36, "Program Suspend/Resume Flowchart" on page 79](#)).

When a programming operation is executing, issuing the Program Suspend command requests the WSM to suspend the programming algorithm at predetermined points. The device continues to output Status Register data after the Program Suspend command is issued. Programming is suspended when Status Register bits SR[7,2] are set. Suspend latency is specified in [Section 16.0, "Program and Erase Characteristics" on page 63](#).

To read data from the device, the Read Array command must be issued. Read Array, Read Status Register, Read Device Identifier, Read CFI, and Program Resume are valid commands during a program suspend.

During a program suspend, deasserting CE# places the device in standby, reducing active current. V_{pp} must remain at its programming level, and WP# must remain unchanged while in program suspend. If RST# is asserted, the device is reset.

8.5 Program Resume

The Resume command instructs the device to continue programming, and automatically clears Status Register bits SR[7,2]. This command can be written to any address. If error bits are set, the Status Register should be cleared before issuing the next instruction. RST# must remain deasserted (see [Figure 36, "Program Suspend/Resume Flowchart" on page 79](#)).

8.6 Program Protection

When $V_{pp} = V_{IL}$, absolute hardware write protection is provided for all device blocks. If V_{pp} is at or below V_{pPLK} , programming operations halt and SR.3 is set indicating a V_{pp} -level error. Block lock registers are not affected by the voltage level on V_{pp} ; they may still be programmed and read, even if V_{pp} is less than V_{pPLK} .

Figure 11: Example VPP Supply Connections

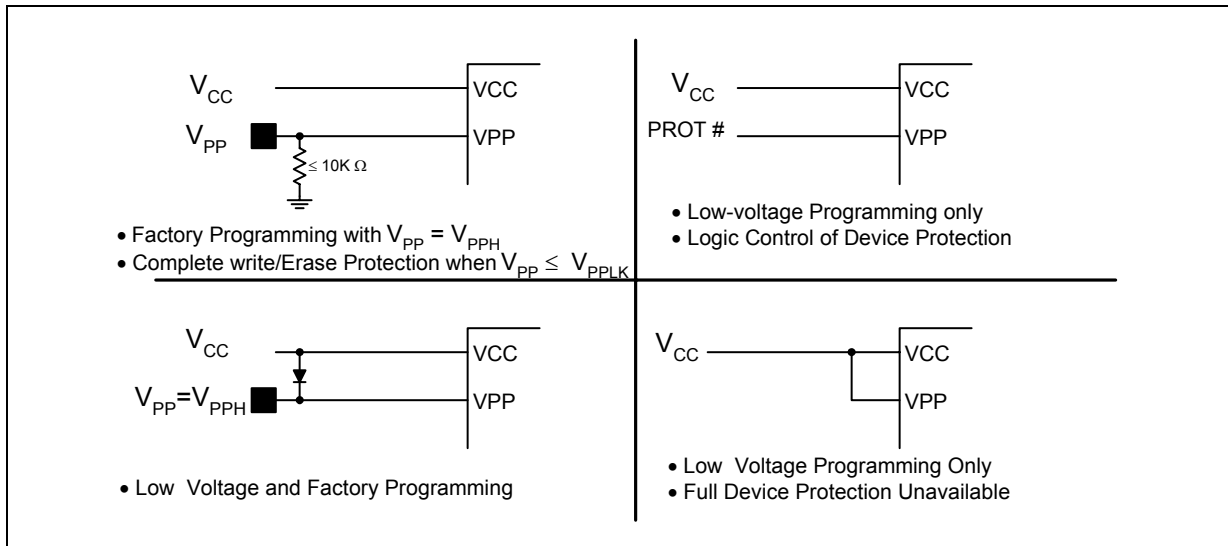

9.0 Erase Operations

Flash erasing is performed on a block basis. An entire block is erased each time an erase command sequence is issued, and only one block is erased at a time. When a block is erased, all bits within that block read as logical ones. The following sections describe block erase operations in detail.

9.1 Block Erase

Block erase operations are initiated by writing the Block Erase Setup command to the address of the block to be erased (see [Section 6.0, "Command Set" on page 21](#)). Next, the Block Erase Confirm command is written to the address of the block to be erased. If the device is placed in standby (CE# deasserted) during an erase operation, the device completes the erase operation before entering standby. V_{PP} must be above V_{PPLK} and the block must be unlocked (see [Figure 39, "Block Erase Flowchart" on page 82](#)).

During a block erase, the Write State Machine (WSM) executes a sequence of internally-timed events that conditions, erases, and verifies all bits within the block. Erasing the flash memory array changes "zeros" to "ones". Memory block array that are ones can be changed to zeros only by programming the block (see [Section 8.0, "Program Operation" on page 27](#)).

The Status Register can be examined for block erase progress and errors by reading any address. The device remains in the Read Status Register state until another command is written. SR.0 indicates whether the addressed block is erasing. Status Register bit SR.7 is set upon erase completion.

Status Register bit SR.7 indicates block erase status while the sequence executes. When the erase operation has finished, Status Register bit SR.5 indicates an erase failure if set. SR.3 set would indicate that the WSM could not perform the erase operation because V_{PP} was outside of its acceptable limits. SR.1 set indicates that the erase operation attempted to erase a locked block, causing the operation to abort.

Before issuing a new command, the Status Register contents should be examined and then cleared using the Clear Status Register command. Any valid command can follow once the block erase operation has completed.

9.2 Blank Check

The Blank Check operation determines whether a specified main block is blank (i.e. completely erased). Without Blank Check, Block Erase would be the only other way to ensure a block is completely erased. Blank Check is especially useful in the case of erase operation interrupted by a power loss event.

Blank check can apply to only one block at a time, and no operations other than Status Register Reads are allowed during Blank Check (e.g. reading array data, program, erase etc). Suspend and resume operations are not supported during Blank Check, nor is Blank Check supported during any suspended operations.

Blank Check operations are initiated by writing the Blank Check Setup command to the block address. Next, the Check Confirm command is issued along with the same block address. When a successful command sequence is entered, the device automatically enters the Read Status State. The WSM then reads the entire specified block, and determines whether any bit in the block is programmed or over-erased.

The status register can be examined for Blank Check progress and errors by reading any address within the block being accessed. During a blank check operation, the Status Register indicates a busy status (SR.7 = 0). Upon completion, the Status Register indicates a ready status (SR.7 = 1). The Status Register should be checked for any errors, and then cleared. If the Blank Check operation fails, which means the block is not completely erased, the Status Register bit SR.5 will be set ("1"). CE# or OE# toggle (during polling) updates the Status Register.

After examining the Status Register, it should be cleared by the Clear Status Register command before issuing a new command. The device remains in Status Register Mode until another command is written to the device. Any command can follow once the Blank Check command is complete.

9.3 Erase Suspend

Issuing the Erase Suspend command while erasing suspends the block erase operation. This allows data to be accessed from memory locations other than the one being erased. The Erase Suspend command can be issued to any device address. A block erase operation can be suspended to perform a word or buffer program operation, or a read operation within any block except the block that is erase suspended (see [Figure 40, "Erase Suspend/Resume Flowchart" on page 83](#)).

When a block erase operation is executing, issuing the Erase Suspend command requests the WSM to suspend the erase algorithm at predetermined points. The device continues to output Status Register data after the Erase Suspend command is issued. Block erase is suspended when Status Register bits SR[7,6] are set. Suspend latency is specified in [Section 16.0, "Program and Erase Characteristics" on page 63](#).

To read data from the device (other than an erase-suspended block), the Read Array command must be issued. During Erase Suspend, a Program command can be issued to any block other than the erase-suspended block. Block erase cannot resume until program operations initiated during erase suspend complete. Read Array, Read Status Register, Read Device Identifier, Read CFI, and Erase Resume are valid commands during Erase Suspend. Additionally, Clear Status Register, Program, Program Suspend, Block Lock, Block Unlock, and Block Lock-Down are valid commands during Erase Suspend.

During an erase suspend, deasserting CE# places the device in standby, reducing active current. V_{pp} must remain at a valid level, and WP# must remain unchanged while in erase suspend. If RST# is asserted, the device is reset.

9.4 Erase Resume

The Erase Resume command instructs the device to continue erasing, and automatically clears status register bits SR[7,6]. This command can be written to any address. If status register error bits are set, the Status Register should be cleared before issuing the next instruction. RST# must remain deasserted (see [Figure 40, "Erase Suspend/Resume Flowchart" on page 83](#)).

9.5 Erase Protection

When $V_{pp} = V_{IL}$, absolute hardware erase protection is provided for all device blocks. If V_{pp} is at or below V_{PPLK} , erase operations halt and SR.3 is set indicating a V_{pp} -level error.

10.0 Security Modes

The device features security modes used to protect the information stored in the flash memory array. The following sections describe each security mode in detail.

10.1 Block Locking

Individual instant block locking is used to protect user code and/or data within the flash memory array. All blocks power-up in a locked state to protect array data from being altered during power transitions. Any block can be locked or unlocked with no latency. Locked blocks cannot be programmed or erased; they can only be read.

Software-controlled security is implemented using the Block Lock and Block Unlock commands. Hardware-controlled security can be implemented using the Block Lock-Down command along with asserting WP#. Also, V_{PP} data security can be used to inhibit program and erase operations (see [Section 8.6, "Program Protection" on page 31](#) and [Section 9.5, "Erase Protection" on page 34](#)).

10.1.1 Lock Block

To lock a block, issue the Block Lock Setup command, followed by the Block Lock command issued to the desired block's address. If the Set Read Configuration Register command is issued after the Block Lock Setup command, the device configures the RCR instead.

Block lock and unlock operations are not affected by the voltage level on V_{PP}. The block lock bits may be modified and/or read even if V_{PP} is at or below V_{PPLK}.

10.1.2 Unlock Block

The Block Unlock command is used to unlock blocks (see [Section 6.0, "Command Set" on page 21](#)). Unlocked blocks can be read, programmed, and erased. Unlocked blocks return to a locked state when the device is reset or powered down. If a block is in a lock-down state, WP# must be deasserted before it can be unlocked (see [Figure 12, "Block Locking State Diagram" on page 36](#)).

10.1.3 Lock-Down Block

A locked or unlocked block can be locked-down by writing the Block Lock-Down command sequence (see [Section 6.0, "Command Set" on page 21](#)). Blocks in a lock-down state cannot be programmed or erased; they can only be read. However, unlike locked blocks, their locked state cannot be changed by software commands alone. A locked-down block can only be unlocked by issuing the Block Unlock command with WP# deasserted. To return an unlocked block to locked-down state, a Block Lock-Down command must be issued prior to changing WP# to V_{IL}. Locked-down blocks revert to the locked state upon reset or power up the device (see [Figure 12, "Block Locking State Diagram" on page 36](#)).

10.1.4 Block Lock Status

The Read Device Identifier command is used to determine a block's lock status (see [Section 12.0, "Power and Reset Specifications" on page 48](#)). Data bits DQ[1:0] display the addressed block's lock status; DQ0 is the addressed block's lock bit, while DQ1 is the addressed block's lock-down bit.

Figure 12: Block Locking State Diagram

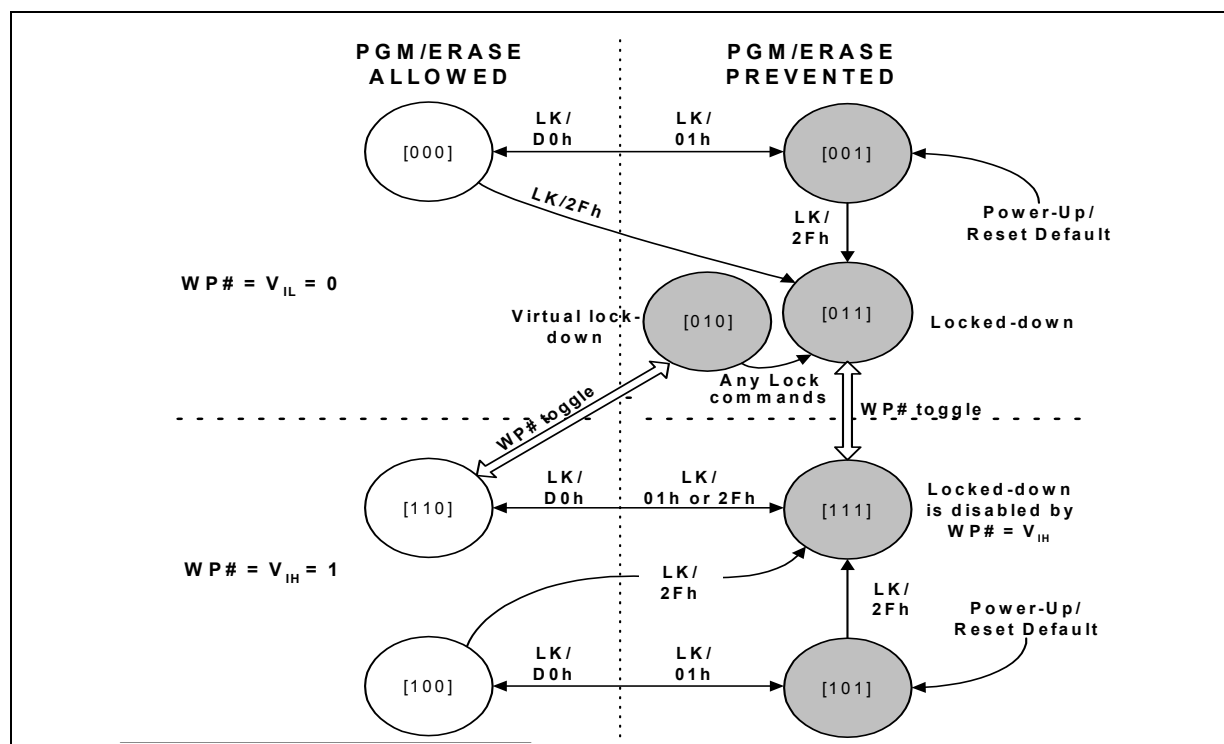

Note: LK: Lock Setup Command, 60h; LK/D0h: Unlock Command; LK/01h: Lock Command; LK/2Fh: Lock-Down Command.

10.1.5 Block Locking During Suspend

Block lock and unlock changes can be performed during an erase suspend. To change block locking during an erase operation, first issue the Erase Suspend command. Monitor the Status Register until SR.7 and SR.6 are set, indicating the device is suspended and ready to accept another command.

Next, write the desired lock command sequence to a block, which changes the lock state of that block. After completing block lock or unlock operations, resume the erase operation using the Erase Resume command.

Note: A Lock Block Setup command followed by any command other than Lock Block, Unlock Block, or Lock-Down Block produces a command sequence error and set Status Register bits SR.4 and SR.5. If a command sequence error occurs during an erase suspend, SR.4 and SR.5 remains set, even after the erase operation is resumed. Unless the Status Register is cleared using the Clear Status Register command before resuming the erase operation, possible erase errors may be masked by the command sequence error.

If a block is locked or locked-down during an erase suspend of the *same* block, the lock status bits change immediately. However, the erase operation completes when it is resumed. Block lock operations cannot occur during a program suspend. See [Appendix A, "Write State Machine" on page 87](#), which shows valid commands during an erase suspend.

10.2 Selectable One-Time Programmable Blocks

The OTP security feature on P30-65nm device is backward compatible to the P30-130nm device. Please see your local Numonyx representative for details about its implementation.

10.3 Password Access

The Password Access is a security enhancement offered on the P30-65nm device. This feature protects information stored in array blocks by preventing content alteration or reads until a valid 64-bit password is received. The Password Access may be combined with Non-Volatile Protection and/or Volatile Protection to create a multi-tiered solution.

Please contact your Numonyx Sales for further details concerning Password Access.

11.0 Registers

When non-array reads are performed in asynchronous page mode only the first data is valid and all subsequent data are undefined. When a non-array read operation occurs as synchronous burst mode, the same word of data requested will be output on successive clock edges until the burst length requirements are satisfied.

11.1 Read Status Register

To read the Status Register, issue the Read Status Register command at any address. Status Register information is available to which the Read Status Register, Word Program, or Block Erase command was issued. Status Register data is automatically made available following a Word Program, Block Erase, or Block Lock command sequence. Reads from the device after any of these command sequences outputs the device's status until another valid command is written (e.g. Read Array command).

The Status Register is read using single asynchronous-mode or synchronous burst mode reads. Status Register data is output on DQ[7:0], while 0x00 is output on DQ[15:8]. In asynchronous mode the falling edge of OE#, or CE# (whichever occurs first) updates and latches the Status Register contents. However, reading the Status Register in synchronous burst mode, CE# or ADV# must be toggled to update status data.

The Device Write Status bit (SR.7) provides overall status of the device. Status register bits SR[6:1] present status and error information about the program, erase, suspend, V_{pp}, and block-locked operations.

Table 14: Status Register Description (Sheet 1 of 2)

Status Register (SR)							Default Value = 0x80	
Device Write Status	Erase Suspend Status	Erase Status	Program Status	V _{pp} Status	Program Suspend Status	Block-Locked Status	BEFP Status	
DWS	ESS	ES	PS	VPPS	PSS	BLS	BWS	
7	6	5	4	3	2	1	0	
Bit	Name		Description					
7	Device Ready Status (DWS)		0 = Device is busy; program or erase cycle in progress; SR.0 valid. 1 = Device is ready; SR[6:1] are valid.					
6	Erase Suspend Status (ESS)		0 = Erase suspend not in effect. 1 = Erase suspend in effect.					
5	Erase Status (ES)	Command Sequence Error	SR.5	SR.4	Description			
4	Program Status (PS)		0	0	Program or Erase operation successful.			
			0	1	Program error - operation aborted.			
			1	0	Erase error - operation aborted.			
1	1	Command sequence error - command aborted.						
3	V _{pp} Status (VPPS)		0 = VPP within acceptable limits during program or erase operation. 1 = VPP ≤ VPPLK during program or erase operation.					

Table 14: Status Register Description (Sheet 2 of 2)

Status Register (SR)		Default Value = 0x80
2	Program Suspend Status (PSS)	0 = Program suspend not in effect. 1 = Program suspend in effect.
1	Block-Locked Status (BLS)	0 = Block not locked during program or erase. 1 = Block locked during program or erase; operation aborted.
0	BEFP Status (BWS)	After Buffered Enhanced Factory Programming (BEFP) data is loaded into the buffer: 0 = BEFP complete. 1 = BEFP in-progress.

Note: Always clear the Status Register prior to resuming erase operations. It avoids Status Register ambiguity when issuing commands during Erase Suspend. If a command sequence error occurs during an erase-suspend state, the Status Register contains the command sequence error status (SR[7,5,4] set). When the erase operation resumes and finishes, possible errors during the erase operation cannot be detected via the Status Register because it contains the previous error status.

11.1.1 Clear Status Register

The Clear Status Register command clears the status register. It functions independent of V_{pp} . The Write State Machine (WSM) sets and clears SR[7,6,2], but it sets bits SR[5:3,1] without clearing them. The Status Register should be cleared before starting a command sequence to avoid any ambiguity. A device reset also clears the Status Register.

11.2 Read Configuration Register

The RCR is a 16-bit read/write register used to select bus-read mode (synchronous or asynchronous), and to configure synchronous burst read characteristics of the device. To modify RCR settings, use the Configure Read Configuration Register command (see [Section 6.0, "Command Set" on page 21](#)).

RCR contents can be examined using the Read Device Identifier command, and then reading from offset 0x05 (see [Section 12.0, "Power and Reset Specifications" on page 48](#)).

Upon power-up or exit from reset, the RCR defaults to asynchronous mode.

The following sections describe each RCR bit.

Table 15: Read Configuration Register Description (Sheet 1 of 2)

Read Configuration Register (RCR)															
Read Mode	Latency Count				WAIT Polarity	RES	WAIT Delay	Burst Seq	CLK Edge	RES	RES	Burst Wrap	Burst Length		
RM	LC[3:0]				WP	R	WD	BS	CE	R	R	BW	BL[2:0]		
15	14	13	12	11	10	9	8	7	6	5	4	3	2	1	0
Bit	Name				Description										
15	Read Mode (RM)				0 = Synchronous burst-mode read 1 = Asynchronous page-mode read (default)										

Table 15: Read Configuration Register Description (Sheet 2 of 2)

14:11	Latency Count (LC[3:0])	0010 =Code 2 0011 =Code 3 0100 =Code 4 0101 =Code 5 0110 =Code 6 0111 =Code 7 1000 =Code 8 1001 =Code 9 1010 =Code 10 1011 =Code 11 1100 =Code 12 1101 =Code 13 1110 =Code 14 1111 =Code 15 (default) (Other bit settings are reserved)
10	WAIT Polarity (WP)	0 =WAIT signal is active low (default) 1 =WAIT signal is active high
9	Reserved (R)	Default "0", Non-changeable
8	WAIT Delay (WD)	0 =WAIT deasserted with valid data 1 =WAIT deasserted one data cycle before valid data (default)
7	Burst Sequence (BS)	Default "0", Non-changeable
6	Clock Edge (CE)	0 = Falling edge 1 = Rising edge (default)
5:4	Reserved (R)	Default "0", Non-changeable
3	Burst Wrap (BW)	0 =Wrap; Burst accesses wrap within burst length set by BL[2:0] 1 =No Wrap; Burst accesses do not wrap within burst length (default)
2:0	Burst Length (BL[2:0])	001 =4-word burst 010 =8-word burst 011 =16-word burst 111 =Continuous-word burst (default) (Other bit settings are reserved)

11.2.1 Read Mode

The Read Mode (RM) bit selects synchronous burst-mode or asynchronous page-mode operation for the device. When the RM bit is set, asynchronous page mode is selected (default). When RM is cleared, synchronous burst mode is selected.

11.2.2 Latency Count

The Latency Count (LC) bits tell the device how many clock cycles must elapse from the rising edge of ADV# (or from the first valid clock edge after ADV# is asserted) until the first valid data word is to be driven onto DQ[15:0]. The input clock frequency is used to determine this value and [Figure 13](#) shows the data output latency for the different settings of LC. The minimum Latency Count for P30-65nm would be Code 4 based on the Max Clock frequency specification of 52 MHz, and there will be zero WAIT States when bursting within the word line. Please also refer to [Section 11.2.3, "End of Word Line \(EOWL\) Considerations" on page 42](#) for more information on EOWL.

Refer to [Table 16, "LC and Frequency Support" on page 42](#) for Latency Code Settings.

Figure 13: First-Access Latency Count

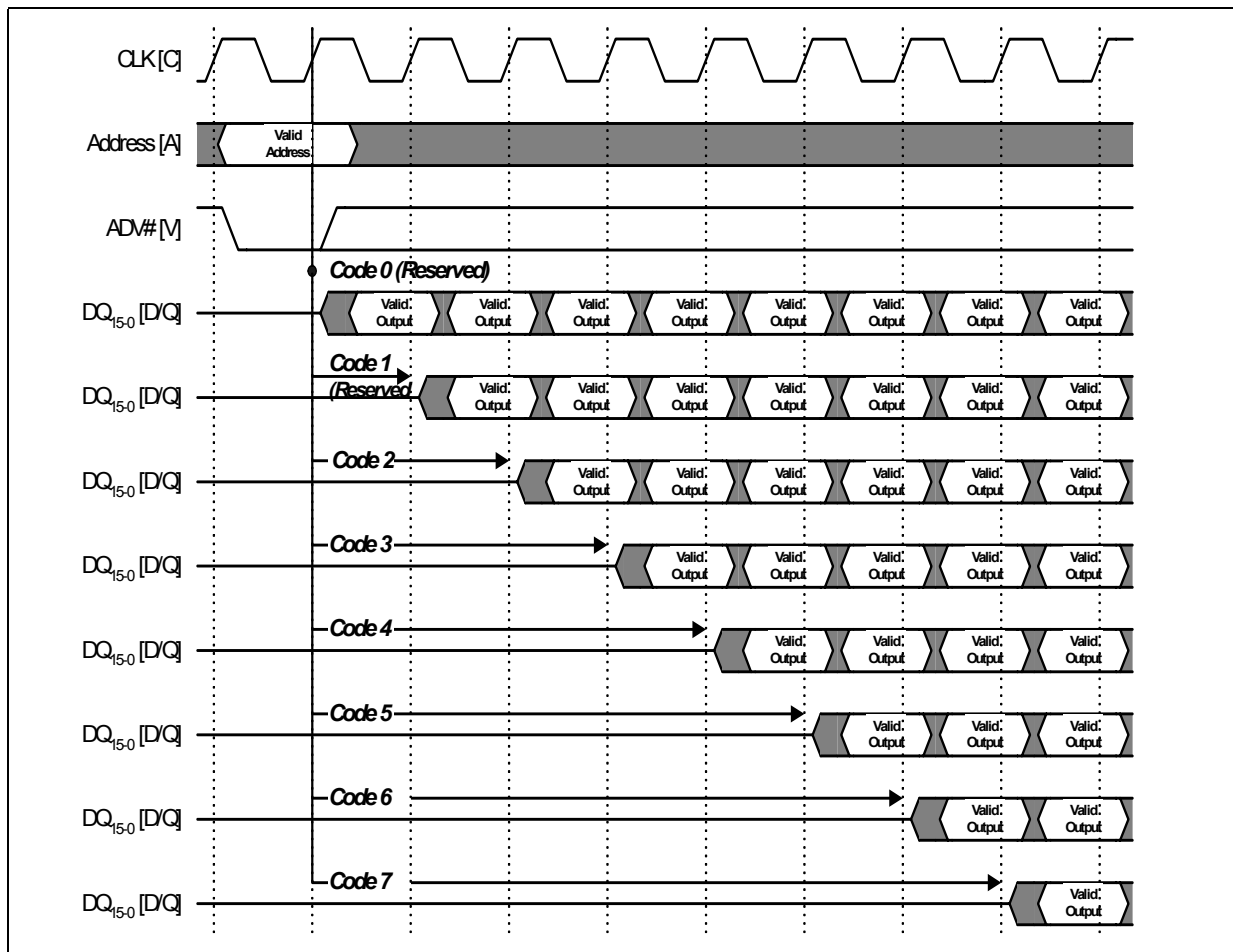
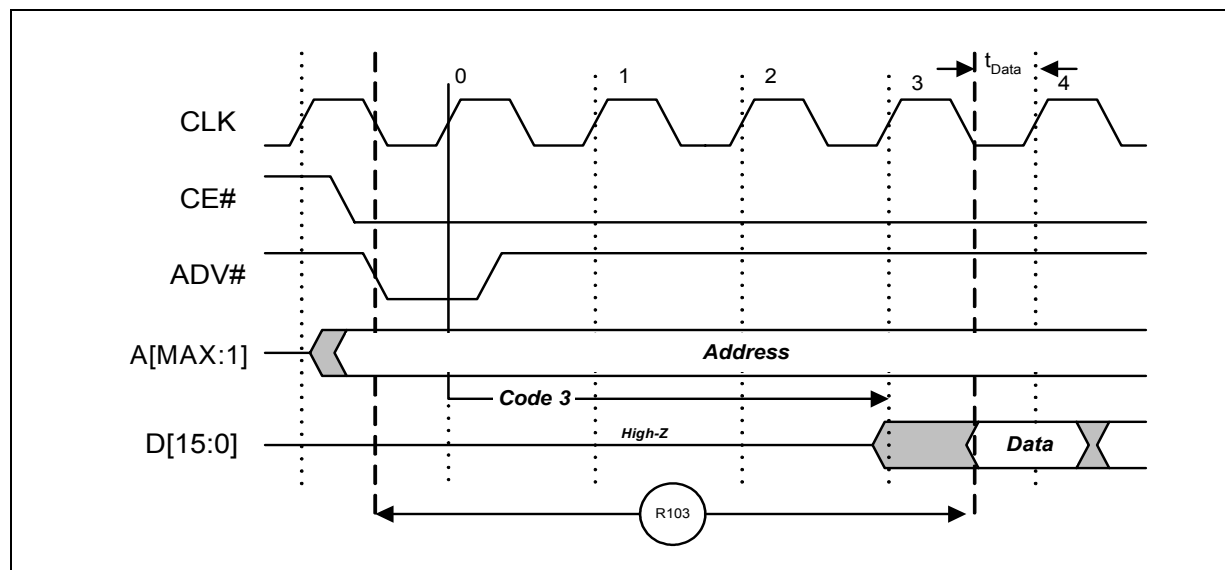

Table 16: LC and Frequency Support

Latency Count Settings	Frequency Support (MHz)
5 (TSOP); 4 (Easy BGA)	≤ 40
5 (Easy BGA)	≤ 52

Figure 14: Example Latency Count Setting using Code 3



11.2.3 End of Word Line (EOWL) Considerations

End of Wordline (EOWL) WAIT states can result when the starting address of the burst operation is not aligned to a 16-word boundary; that is, A[3:0] of start address does not equal 0x0. [Figure 15, "End of Wordline Timing Diagram" on page 42](#) illustrates the end of wordline WAIT state(s), which occur after the first 16-word boundary is reached. The number of data words and the number of WAIT states is summarized in [Table 17, "End of Wordline Data and WAIT state Comparison" on page 43](#) for both P30-130nm and P30-65nm devices.

Figure 15: End of Wordline Timing Diagram

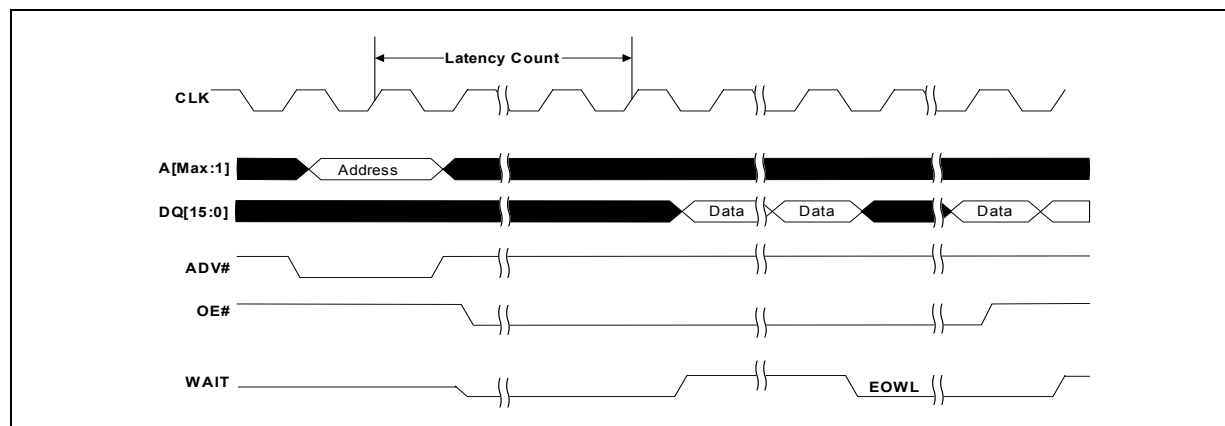

Table 17: End of Wordline Data and WAIT state Comparison

Latency Count	P30-130nm		P30-65nm	
	Data States	WAIT States	Data States	WAIT States
1	Not Supported	Not Supported	Not Supported	Not Supported
2	4	0 to 1	Not Supported	Not Supported
3	4	0 to 2	16	0 to 2
4	4	0 to 3	16	0 to 3
5	4	0 to 4	16	0 to 4
6	4	0 to 5	16	0 to 5
7	4	0 to 6	16	0 to 6
8	Not Supported	Not Supported	16	0 to 7
9			16	0 to 8
10			16	0 to 9
11			16	0 to 10
12			16	0 to 11
13			16	0 to 12
14			16	0 to 13
15			16	0 to 14

11.2.4 WAIT Polarity

The WAIT Polarity bit (WP), RCR.10 determines the asserted level (V_{OH} or V_{OL}) of WAIT. When WP is set, WAIT is asserted high (default). When WP is cleared, WAIT is asserted low. WAIT changes state on valid clock edges during active bus cycles (CE# asserted, OE# asserted, RST# deasserted).

11.2.4.1 WAIT Signal Function

The WAIT signal indicates data valid when the device is operating in synchronous mode (RCR.15 = 0). The WAIT signal is only "deasserted" when data is valid on the bus.

When the device is operating in synchronous non-array read mode, such as read status, read ID, or read CFI. The WAIT signal is also "deasserted" when data is valid on the bus.

WAIT behavior during synchronous non-array reads at the end of word line works correctly only on the first data access.

When the device is operating in asynchronous page mode, asynchronous single word read mode, and all write operations, WAIT is set to a deasserted state as determined by RCR.10. See [Figure 22, "Asynchronous Single-Word Read \(ADV# Latch\)" on page 56](#), and [Figure 23, "Asynchronous Page-Mode Read Timing" on page 57](#).

Table 18: WAIT Functionality Table

Condition	WAIT	Notes
CE# = '1', OE# = 'X' or CE# = '0', OE# = '1'	High-Z	1
CE# = '0', OE# = '0'	Active	1
Synchronous Array Reads	Active	1
Synchronous Non-Array Reads	Active	1
All Asynchronous Reads	Deasserted	1
All Writes	High-Z	1,2

Notes:

1. **Active:** WAIT is asserted until data becomes valid, then deasserts
2. When OE# = V_{IH} during writes, WAIT = High-Z

11.2.5 WAIT Delay

The WAIT Delay (WD) bit controls the WAIT assertion-delay behavior during synchronous burst reads. WAIT can be asserted either during or one data cycle before valid data is output on DQ[15:0]. When WD is set, WAIT is deasserted one data cycle *before* valid data (default). When WD is cleared, WAIT is deasserted *during* valid data.

11.2.6 Burst Sequence

The Burst Sequence (BS) bit selects linear-burst sequence (default). Only linear-burst sequence is supported. [Table 19](#) shows the synchronous burst sequence for all burst lengths, as well as the effect of the Burst Wrap (BW) setting.

Table 19: Burst Sequence Word Ordering (Sheet 1 of 2)

Start Addr. (DEC)	Burst Wrap (RCR.3)	Burst Addressing Sequence (DEC)			
		4-Word Burst (BL[2:0] = 0b001)	8-Word Burst (BL[2:0] = 0b010)	16-Word Burst (BL[2:0] = 0b011)	Continuous Burst (BL[2:0] = 0b111)
0	0	0-1-2-3	0-1-2-3-4-5-6-7	0-1-2-3-4...14-15	0-1-2-3-4-5-6-...
1	0	1-2-3-0	1-2-3-4-5-6-7-0	1-2-3-4-5...15-0	1-2-3-4-5-6-7-...
2	0	2-3-0-1	2-3-4-5-6-7-0-1	2-3-4-5-6...15-0-1	2-3-4-5-6-7-8-...
3	0	3-0-1-2	3-4-5-6-7-0-1-2	3-4-5-6-7...15-0-1-2	3-4-5-6-7-8-9-...
4	0		4-5-6-7-0-1-2-3	4-5-6-7-8...15-0-1-2-3	4-5-6-7-8-9-10-...
5	0		5-6-7-0-1-2-3-4	5-6-7-8-9...15-0-1-2-3-4	5-6-7-8-9-10-11-...
6	0		6-7-0-1-2-3-4-5	6-7-8-9-10...15-0-1-2-3-4-5	6-7-8-9-10-11-12-...
7	0		7-0-1-2-3-4-5-6	7-8-9-10...15-0-1-2-3-4-5-6	7-8-9-10-11-12-13-...
⋮	⋮	⋮	⋮	⋮	⋮
14	0			14-15-0-1-2...12-13	14-15-16-17-18-19-20-...
15	0			15-0-1-2-3...13-14	15-16-17-18-19-20-21-...
⋮	⋮	⋮	⋮	⋮	⋮
0	1	0-1-2-3	0-1-2-3-4-5-6-7	0-1-2-3-4...14-15	0-1-2-3-4-5-6-...

Table 19: Burst Sequence Word Ordering (Sheet 2 of 2)

1	1	1-2-3-4	1-2-3-4-5-6-7-8	1-2-3-4-5...15-16	1-2-3-4-5-6-7-...
2	1	2-3-4-5	2-3-4-5-6-7-8-9	2-3-4-5-6...16-17	2-3-4-5-6-7-8-...
3	1	3-4-5-6	3-4-5-6-7-8-9-10	3-4-5-6-7...17-18	3-4-5-6-7-8-9-...
4	1		4-5-6-7-8-9-10-11	4-5-6-7-8...18-19	4-5-6-7-8-9-10...
5	1		5-6-7-8-9-10-11-12	5-6-7-8-9...19-20	5-6-7-8-9-10-11...
6	1		6-7-8-9-10-11-12-13	6-7-8-9-10...20-21	6-7-8-9-10-11-12-...
7	1		7-8-9-10-11-12-13-14	7-8-9-10-11...21-22	7-8-9-10-11-12-13...
⋮	⋮	⋮	⋮	⋮	⋮
14	1			14-15-16-17-18...28-29	14-15-16-17-18-19-20- ...
15	1			15-16-17-18-19...29-30	15-16-17-18-19-20-21- ...

11.2.7 Clock Edge

The Clock Edge (CE) bit selects either a rising (default) or falling clock edge for CLK. This clock edge is used at the start of a burst cycle, to output synchronous data, and to assert/deassert WAIT.

11.2.8 Burst Wrap

The Burst Wrap (BW) bit determines whether 4-word, 8-word, or 16-word burst length accesses wrap within the selected word-length boundaries or cross word-length boundaries. When BW is set, burst wrapping does not occur (default). When BW is cleared, burst wrapping occurs.

When performing synchronous burst reads with BW set (no wrap), an output delay may occur when the burst sequence crosses its first device-row (16-word) boundary. If the burst sequence's start address is 4-word aligned, then no delay occurs. If the start address is at the end of a 4-word boundary, the worst case output delay is one clock cycle less than the first access Latency Count. This delay can take place only once, and doesn't occur if the burst sequence does not cross a device-row boundary. WAIT informs the system of this delay when it occurs.

11.2.9 Burst Length

The Burst Length bits (BL[2:0]) select the linear burst length for all synchronous burst reads of the flash memory array. The burst lengths are 4-word, 8-word, 16-word or continuous.

Continuous-burst accesses are linear only, and do not wrap within any word length boundaries (see [Table 19, "Burst Sequence Word Ordering" on page 44](#)). When a burst cycle begins, the device outputs synchronous burst data until it reaches the end of the "burstable" address space.

11.3 One-Time-Programmable (OTP) Registers

The device contains 17 one-time programmable (OTP) registers that can be used to implement system security measures and/or device identification. Each OTP register can be individually locked.

The first 128-bit OTP Register is comprised of two 64-bit (8-word) segments. The lower 64-bit segment is pre-programmed at the Numonyx factory with a unique 64-bit number. The upper 64-bit segment, as well as the other sixteen 128-bit OTP Registers,

are blank. Users can program these registers as needed. Once programmed, users can then lock the OTP Register(s) to prevent additional bit programming (see Figure 16, "OTP Register Map" on page 46).

The OTP Registers contain one-time programmable (OTP) bits; when programmed, PR bits cannot be erased. Each OTP Register can be accessed multiple times to program individual bits, as long as the register remains unlocked.

Each OTP Register has an associated Lock Register bit. When a Lock Register bit is programmed, the associated OTP Register can only be read; it can no longer be programmed. Additionally, because the Lock Register bits themselves are OTP, when programmed, Lock Register bits cannot be erased. Therefore, when a OTP Register is locked, it cannot be unlocked.

Figure 16: OTP Register Map

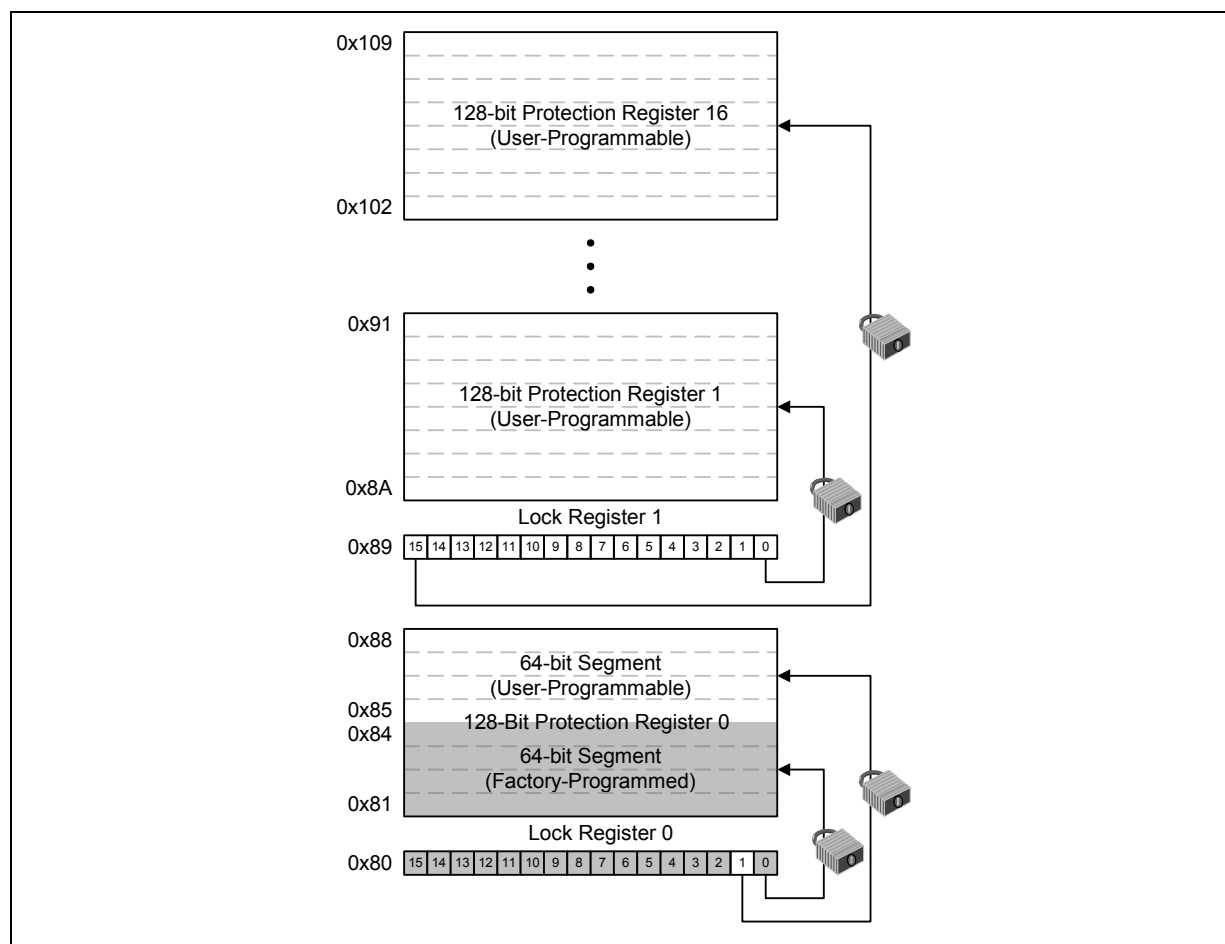

11.3.1 Reading the OTP Registers

The OTP Registers can be read from OTP-RA address. To read the OTP Register, first issue the Read Device Identifier command at OTP-RA address to place the device in the Read Device Identifier state (see Section 6.0, "Command Set" on page 21). Next,

perform a read operation using the address offset corresponding to the register to be read. [Table 10, "Device Identifier Information" on page 26](#) shows the address offsets of the OTP Registers and Lock Registers. PR data is read 16 bits at a time.

11.3.2 Programming the OTP Registers

To program an OTP Register, first issue the Program OTP Register command at the parameter's base address plus the offset of the desired OTP Register location (see [Section 6.0, "Command Set" on page 21](#)). Next, write the desired OTP Register data to the same OTP Register address (see [Figure 16, "OTP Register Map" on page 46](#)).

The device programs the 64-bit and 128-bit user-programmable OTP Register data 16 bits at a time (see [Figure 42, "Protection Register Programming Flowchart" on page 85](#)). Issuing the Program OTP Register command outside of the OTP Register's address space causes a program error (SR.4 set). Attempting to program a locked OTP Register causes a program error (SR.4 set) and a lock error (SR.1 set).

Note: When programming the OTP bits in the OTP registers for a **Top Parameter Device**, the following upper address bits must also be driven properly: A[Max:17] driven high (V_{IH}) for TSOP and Easy BGA packages, and A[Max:16] driven high (V_{IH}) for QUAD+ SCSP.

11.3.3 Locking the OTP Registers

Each OTP Register can be locked by programming its respective lock bit in the Lock Register. To lock a OTP Register, program the corresponding bit in the Lock Register by issuing the Program Lock Register command, followed by the desired Lock Register data (see [Section 6.0, "Command Set" on page 21](#)). The physical addresses of the Lock Registers are 0x80 for register 0 and 0x89 for register 1. These addresses are used when programming the lock registers (see [Table 10, "Device Identifier Information" on page 26](#)).

Bit 0 of Lock Register 0 is already programmed during the manufacturing process by Numonyx factory, locking the lower half segment of the first 128-bit OTP Register. Bit 1 of Lock Register 0 can be programmed by user to the upper half segment of the first 128-bit OTP Register. When programming Bit 1 of Lock Register 0, all other bits need to be left as '1' such that the data programmed is 0xFFFFD.

Lock Register 1 controls the locking of the upper sixteen 128-bit OTP Registers. Each bit of Lock Register 1 corresponds to a specific 128-bit OTP Register. Programming a bit in Lock Register 1 locks the corresponding 128-bit OTP Register; e.g., programming LR1.0 locks the corresponding OTP Register 1.

Caution: After being locked, the OTP Registers cannot be unlocked.

12.0 Power and Reset Specifications

12.1 Power-Up and Power-Down

Power supply sequencing is not required if VPP is connected to VCC or VCCQ. Otherwise VCC and VCCQ should attain their minimum operating voltage before applying VPP.

Power supply transitions should only occur when RST# is low. This protects the device from accidental programming or erasure during power transitions.

12.2 Reset Specifications

Asserting RST# during a system reset is important with automated program/erase devices because systems typically expect to read from flash memory when coming out of reset. If a CPU reset occurs without a flash memory reset, proper CPU initialization may not occur. This is because the flash memory may be providing status information, instead of array data as expected. Connect RST# to the same active low reset signal used for CPU initialization.

Also, because the device is disabled when RST# is asserted, it ignores its control inputs during power-up/down. Invalid bus conditions are masked, providing a level of memory protection.

Table 20: Power and Reset

Num	Symbol	Parameter	Min	Max	Unit	Notes
P1	t _{PLPH}	RST# pulse width low	100	-	ns	1,2,3,4
P2	t _{PLRH}	RST# low to device reset during erase	-	25	us	1,3,4,7
		RST# low to device reset during program	-	25		1,3,4,7
P3	t _{VCCPH}	VCC Power valid to RST# de-assertion (high)	300	-		

Notes:

1. These specifications are valid for all device versions (packages and speeds).
2. The device may reset if t_{PLPH} is < t_{PLPH MIN}, but this is not guaranteed.
3. Not applicable if RST# is tied to VCC.
4. Sampled, but not 100% tested.
5. When RST# is tied to the VCC supply, device will not be ready until t_{VCCPH} after VCC ≥ VCCMIN.
6. When RST# is tied to the VCCQ supply, device will not be ready until t_{VCCPH} after VCC ≥ VCCMIN.
7. Reset completes within t_{PLPH} if RST# is asserted while no erase or program operation is executing.

Figure 17: Reset Operation Waveforms

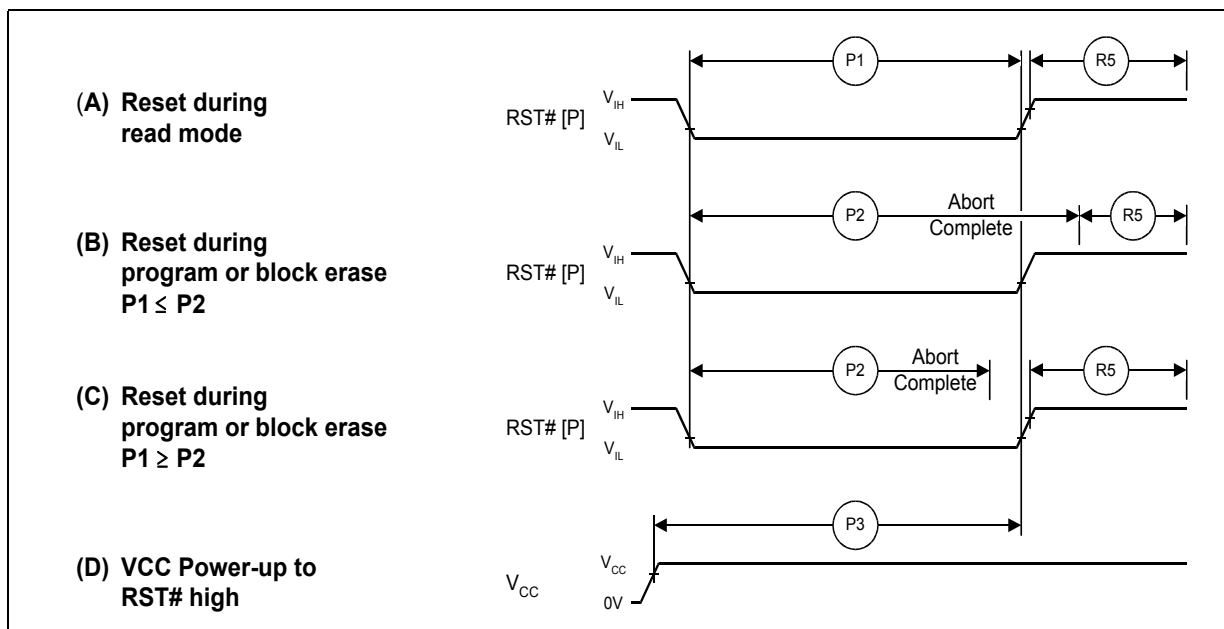

12.3 Power Supply Decoupling

Flash memory devices require careful power supply de-coupling. Three basic power supply current considerations are 1) standby current levels, 2) active current levels, and 3) transient peaks produced when CE# and OE# are asserted and deasserted.

When the device is accessed, many internal conditions change. Circuits within the device enable charge-pumps, and internal logic states change at high speed. All of these internal activities produce transient signals. Transient current magnitudes depend on the device outputs' capacitive and inductive loading. Two-line control and correct de-coupling capacitor selection suppress transient voltage peaks.

Because flash memory devices draw their power from V_{CC}, V_{PP}, and V_{CCQ}, each power connection should have a 0.1 μF ceramic capacitor to ground. High-frequency, inherently low-inductance capacitors should be placed as close as possible to package leads.

Additionally, for every eight devices used in the system, a 4.7 μF electrolytic capacitor should be placed between power and ground close to the devices. The bulk capacitor is meant to overcome voltage droop caused by PCB trace inductance.

13.0 Maximum Ratings and Operating Conditions

13.1 Absolute Maximum Ratings

Warning: Stressing the device beyond the "Absolute Maximum Ratings" may cause permanent damage. These are stress ratings only.

Table 21:

Parameter	Maximum Rating	Notes
Temperature under bias	-40 °C to +85 °C	
Storage temperature	-65 °C to +125 °C	
Voltage on any signal (except V_{CC} , V_{PP} and V_{CCQ})	-0.5 V to +4.1 V	1
V_{PP} voltage	-0.2 V to +10 V	1,2,3
V_{CC} voltage	-0.2 V to +2.5 V	1
V_{CCQ} voltage	-0.2 V to +4.1 V	1
Output short circuit current	100 mA	4

Notes:

1. Voltages shown are specified with respect to V_{SS} . Minimum DC voltage is -0.5 V on input/output signals and -0.2 V on V_{CC} , V_{CCQ} , and V_{PP} . During transitions, this level may undershoot to -2.0 V for periods less than 20 ns. Maximum DC voltage on V_{CC} is $V_{CC} + 0.5$ V, which, during transitions, may overshoot to $V_{CC} + 2.0$ V for periods less than 20 ns. Maximum DC voltage on input/output signals and V_{CCQ} is $V_{CCQ} + 0.5$ V, which, during transitions, may overshoot to $V_{CCQ} + 2.0$ V for periods less than 20 ns.
2. Maximum DC voltage on V_{PP} may overshoot to +11.5 V for periods less than 20 ns.
3. Program/erase voltage is typically 1.7 V - 2.0 V. 9.0 V can be applied for 80 hours maximum total, to any blocks for 1000 cycles maximum. 9.0 V program/erase voltage may reduce block cycling capability.
4. Output shorted for no more than one second. No more than one output shorted at a time.

13.2 Operating Conditions

Note: Operation beyond the "Operating Conditions" is not recommended and extended exposure beyond the "Operating Conditions" may affect device reliability.

Table 22: Operating Conditions

Symbol	Parameter		Min	Max	Unit	Notes	
T_C	Operating Temperature		-40	+85	°C	1	
V_{CC}	V_{CC} Supply Voltage		1.7	2.0	V	3	
V_{CCQ}	I/O Supply Voltage	CMOS inputs	1.7	3.6			
		TTL inputs	2.4	3.6			
V_{PPL}	V_{PP} Voltage Supply (Logic Level)		0.9	3.6			
V_{PPH}	Buffered Enhanced Factory Programming V_{PP}		8.5	9.5	Hours	2	
t_{PPH}	Maximum V_{PP} Hours	$V_{PP} = V_{PPH}$	-	80			
Block Erase Cycles	Main and Parameter Blocks	$V_{PP} = V_{PPL}$	100,000	-			Cycles
	Main Blocks	$V_{PP} = V_{PPH}$	100,000	-			
	Parameter Blocks	$V_{PP} = V_{PPH}$	100,000	-			

Notes:

1. T_C = Case Temperature.
2. In typical operation V_{PP} program voltage is V_{PPL} .

14.0 Electrical Specifications

14.1 DC Current Characteristics

Table 23: DC Current Characteristics (Sheet 1 of 2)

Sym	Parameter		CMOS Inputs (V _{CCQ} = 1.7V - 3.6 V)		TTL Inputs (V _{CCQ} = 2.4 V - 3.6 V)		Unit	Test Conditions	Notes	
			Typ	Max	Typ	Max				
I _{LI}	Input Load Current		-	±1	-	±2	µA	V _{CC} = V _{CCMax} V _{CCQ} = V _{CCQMax} V _{IN} = V _{CCQ} or V _{SS}	1,6	
I _{LO}	Output Leakage Current	DQ[15:0], WAIT	-	±1	-	±10	µA	V _{CC} = V _{CCMax} V _{CCQ} = V _{CCQMax} V _{IN} = V _{CCQ} or V _{SS}		
I _{CCS} , I _{CCD}	V _{CC} Standby, Power-Down		256-Mbit	65	210	65	210	µA	V _{CC} = V _{CCMax} V _{CCQ} = V _{CCQMax} CE# = V _{CCQ} RST# = V _{CCQ} (for I _{CCS}) RST# = V _{SS} (for I _{CCD}) WP# = V _{IH}	1.2
		512-Mbit	130	420	130	420				
I _{CCR}	Average V _{CC} Read Current	Asynchronous Single-Word f = 5 MHz (1 CLK)	26	31	26	31	mA	16-Word Read	V _{CC} = V _{CCMax} CE# = V _{IL} OE# = V _{IH} Inputs: V _{IL} or V _{IH}	1
		Page-Mode Read f = 13 MHz (17 CLK)	12	16	12	16	mA	16-Word Read		
		Synchronous Burst f = 52 MHz, LC=4	19	22	19	22	mA	8-Word Read		
			16	18	16	18	mA	16-Word Read		
			21	24	21	24	mA	Continuous Read		
I _{CCW} , I _{CCCE}	V _{CC} Program Current, V _{CC} Erase Current		35	50	35	50	mA	V _{PP} = V _{PP,L} , Pgm/Ers in progress	1,3,5	
			35	50	35	50		V _{PP} = V _{PP,H} , Pgm/Ers in progress		
I _{CCWS} , I _{CCES}	V _{CC} Program Suspend Current, V _{CC} Erase Suspend Current		256-Mbit	65	210	65	210	µA	CE# = V _{CCQ} ; suspend in progress	1,3,4
			512-Mbit	70	225	70	225			
I _{PPS} , I _{PPWS} , I _{PPES}	V _{PP} Standby Current, V _{PP} Program Suspend Current, V _{PP} Erase Suspend Current		0.2	5	0.2	5	µA	V _{PP} = V _{PP,L} , suspend in progress	1,3,7	
I _{PPR}	V _{PP} Read		2	15	2	15	µA	V _{PP} = V _{PP,L}	1,3	
I _{PPW}	V _{PP} Program Current		0.05	0.10	0.05	0.10	mA	V _{PP} = V _{PP,L} , program in progress	-3	
			0.05	0.10	0.05	0.10		V _{PP} = V _{PP,H} , program in progress		
I _{PPE}	V _{PP} Erase Current		0.05	0.10	0.05	0.10	mA	V _{PP} = V _{PP,L} , erase in progress	3	
			0.05	0.10	0.05	0.10		V _{PP} = V _{PP,H} , erase in progress		

Table 23: DC Current Characteristics (Sheet 2 of 2)

Sym	Parameter	CMOS Inputs ($V_{CCQ} = 1.7V - 3.6V$)		TTL Inputs ($V_{CCQ} = 2.4V - 3.6V$)		Unit	Test Conditions	Notes
		Typ	Max	Typ	Max			
I _{PPBC}	V _{PP} Blank Check	0.05	0.10	0.05	0.10	mA	V _{PP} = V _{PPPL} , erase in progress	3
		0.05	0.10	0.05	0.10		V _{PP} = V _{PPPH} , erase in progress	

Notes:

- All currents are RMS unless noted. Typical values at typical V_{CC} , $T_C = +25^\circ C$.
- I_{CCS} is the average current measured over any 5 ms time interval 5 μs after CE# is deasserted.
- Sampled, not 100% tested.
- I_{CCES} is specified with the device deselected. If device is read while in erase suspend, current is I_{CCES} plus I_{CCR} .
- I_{CCW} , I_{CCF} measured over typical or max times specified in [Section 16.0, "Program and Erase Characteristics" on page 63](#).
- if $V_{IN} > V_{CC}$ the input load current increases to 10uA max.
- the I_{PPS} , I_{PPWS} , I_{PPES} Will increase to 200uA when Vpp/WP# is at V_{PPH}.

14.2 DC Voltage Characteristics

Table 24: DC Voltage Characteristics

Sym	Parameter	CMOS Inputs ($V_{CCQ} = 1.7V - 3.6V$)		TTL Inputs (1) ($V_{CCQ} = 2.4V - 3.6V$)		Unit	Test Conditions	Notes
		Min	Max	Min	Max			
V _{IL}	Input Low Voltage	-0.5	0.4	-0.5	0.6	V		2
V _{IH}	Input High Voltage	$V_{CCQ} - 0.4$	$V_{CCQ} + 0.5$	2.0	$V_{CCQ} + 0.5$	V		
V _{OL}	Output Low Voltage	-	0.2	-	0.2	V	$V_{CC} = V_{CC}^{Min}$ $V_{CCQ} = V_{CCQ}^{Min}$ $I_{OL} = 100 \mu A$	-
V _{OH}	Output High Voltage	$V_{CCQ} - 0.2$	-	$V_{CCQ} - 0.2$	-	V	$V_{CC} = V_{CC}^{Min}$ $V_{CCQ} = V_{CCQ}^{Min}$ $I_{OH} = -100 \mu A$	-
V _{PPLK}	V _{PP} Lock-Out Voltage	-	0.4	-	0.4	V		3
V _{LKO}	V _{CC} Lock Voltage	1.0	-	1.0	-	V		-
V _{LKOQ}	V _{CCQ} Lock Voltage	0.9	-	0.9	-	V		-
V _{PPPL}	V _{PP} Voltage Supply (Logic Level)	1.5	3.6	1.5	3.6	V		
V _{PPPH}	Buffered Enhanced Factory Programming V _{PP}	8.5	9.5	8.5	9.5	V		

Notes:

- Synchronous read mode is not supported with TTL inputs.
- V_{IL} can undershoot to -1.0 V for duration of 2ns or less and V_{IH} can overshoot to $V_{CCQ} + 1.0V$ for durations of 2ns or less.
- $V_{PP} \leq V_{PPLK}$ inhibits erase and program operations. Do not use V_{PPPL} and V_{PPPH} outside their valid ranges.

15.0 AC Characteristics

15.1 AC Test Conditions

Figure 18: AC Input/Output Reference Waveform

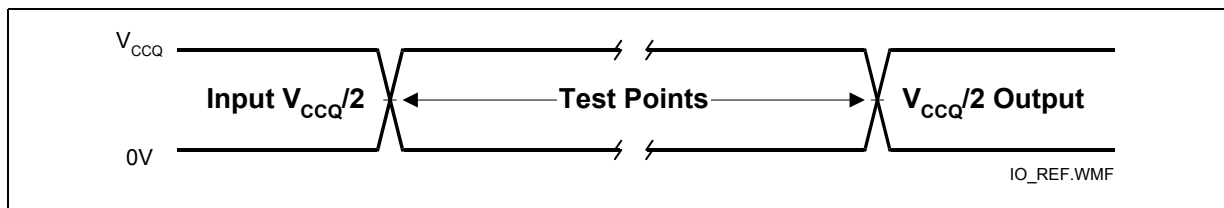

Note: AC test inputs are driven at V_{CCQ} for Logic "1" and 0 V for Logic "0". Input/output timing begins/ends at $V_{CCQ}/2$. Input rise and fall times (10% to 90%) < 5 ns. Worst case speed occurs at $V_{CC} = V_{CCMin}$.

Figure 19: Transient Equivalent Testing Load Circuit

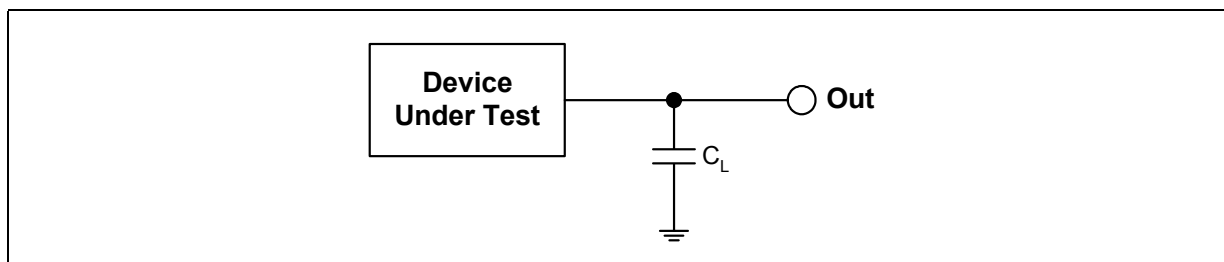

Notes:

1. See the following table for component values.
2. Test configuration component value for worst-case speed conditions.
3. C_L includes jig capacitance.

Table 25: Test Configuration Component Value For Worst Case Speed Conditions

Test Configuration	C_L (pF)
V_{CCQMin} Standard Test	30

Figure 20: Clock Input AC Waveform

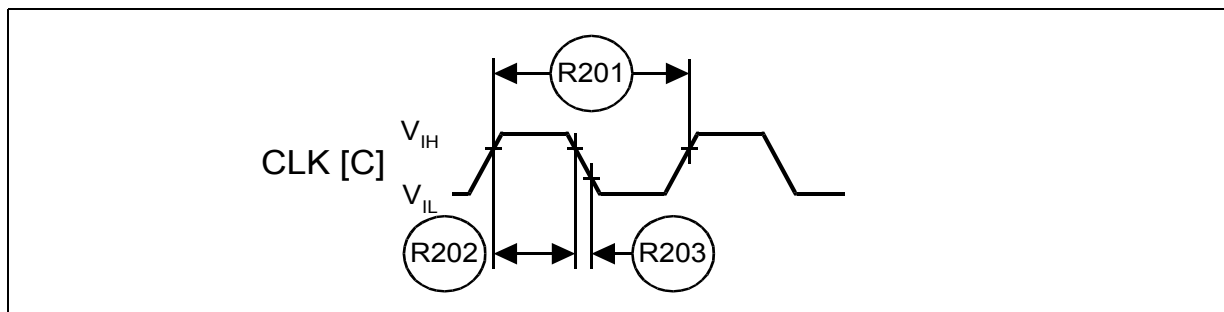

15.2 Capacitance

Table 26: Capacitance

Parameter	Signals	Min	Typ	Max	Unit	Condition	Note
Input Capacitance	Address, Data, CE#, WE#, OE#, RST#, CLK, ADV#, WP#	256-Mbit	3	7	8	pF	Typ temp = 25 °C, Max temp = 85 °C, V _{CC} = (0 V - 2.0 V), V _{CCQ} = (0 V - 3.6 V), Discrete silicon die
		256-Mbit/256Mbit	6	14	16		
Output Capacitance	Data, WAIT	256-Mbit	3	5	7		
		256-Mbit/256Mbit	6	10	14		

Notes:

1. Sampled, but not 100% tested.

15.3 AC Read Specifications

Table 27: AC Read Specifications (Sheet 1 of 2)

Num	Symbol	Parameter	Min	Max	Unit	Note	
Asynchronous Specifications							
R1	t _{AVAV}	Read cycle time	Easy BGA	100	-	ns	-
			TSOP	110		ns	-
R2	t _{AVQV}	Address to output valid	Easy BGA	-	100	ns	-
			TSOP		110	ns	-
R3	t _{ELQV}	CE# low to output valid	Easy BGA	-	100	ns	-
			TSOP		110	ns	-
R4	t _{GLQV}	OE# low to output valid	-	25	ns	1,2	
R5	t _{PHQV}	RST# high to output valid	-	150	ns	1	
R6	t _{ELQX}	CE# low to output in low-Z	0	-	ns	1,3	
R7	t _{GLQX}	OE# low to output in low-Z	0	-	ns	1,2,3	
R8	t _{EHQZ}	CE# high to output in high-Z	-	20	ns	1,3	
R9	t _{GHQZ}	OE# high to output in high-Z	-	15	ns		
R10	t _{OH}	Output hold from first occurring address, CE#, or OE# change	0	-	ns		
R11	t _{EHEL}	CE# pulse width high	17	-	ns	1	
R12	t _{ELTV}	CE# low to WAIT valid	-	17	ns		
R13	t _{EHTZ}	CE# high to WAIT high-Z	-	20	ns	1,3	
R15	t _{GLTV}	OE# low to WAIT valid	-	17	ns	1	
R16	t _{GLTX}	OE# low to WAIT in low-Z	0	-	ns	1,3	
R17	t _{GHTZ}	OE# high to WAIT in high-Z	-	20	ns		
Latching Specifications							

Table 27: AC Read Specifications (Sheet 2 of 2)

Num	Symbol	Parameter	Min	Max	Unit	Note	
R101	t_{AVVH}	Address setup to ADV# high	10	-	ns	1	
R102	t_{ELVH}	CE# low to ADV# high	10	-	ns		
R103	t_{VLQV}	ADV# low to output valid	-	-	100		ns
			TSOP	-	110		ns
R104	t_{VLVH}	ADV# pulse width low	10	-	ns		
R105	t_{VHVL}	ADV# pulse width high	10	-	ns		
R106	t_{VHAX}	Address hold from ADV# high	9	-	ns	1,4	
R108	t_{APA}	Page address access	-	25	ns	1	
R111	t_{phvh}	RST# high to ADV# high	30	-	ns		
Clock Specifications							
R200	f_{CLK}	CLK frequency	-	-	52	MHz	1,3,5
			TSOP	-	40	MHz	
R201	t_{CLK}	CLK period	-	19.2	-	ns	
			TSOP	25	-	ns	
R202	$t_{CH/CL}$	CLK high/low time	-	5	-	ns	
			TSOP	9	-	ns	
R203	$t_{FCLK/RCLK}$	CLK fall/rise time	0.3	3	ns		
Synchronous Specifications⁽⁵⁾							
R301	$t_{AVCH/L}$	Address setup to CLK	-	9	-	ns	1,6
R302	$t_{VLCH/L}$	ADV# low setup to CLK	-	9	-	ns	
R303	$t_{ELCH/L}$	CE# low setup to CLK	-	9	-	ns	
R304	t_{CHQV} / t_{CLQV}	CLK to output valid	-	-	17	ns	
			TSOP	-	20	ns	
R305	t_{CHQX}	Output hold from CLK	-	3	-	ns	1,6
R306	t_{CHAX}	Address hold from CLK	-	10	-	ns	1,4,6
R307	t_{CHTV}	CLK to WAIT valid	-	-	17	ns	1,6
			TSOP	-	20		
R311	t_{CHVL}	CLK Valid to ADV# Setup	-	3	-	ns	1
R312	t_{CHTX}	WAIT Hold from CLK	-	3	-	ns	1,6

Notes:

1. See Figure 18, "AC Input/Output Reference Waveform" on page 53 for timing measurements and max allowable input slew rate.
2. OE# may be delayed by up to $t_{ELQV} - t_{GLQV}$ after CE#'s falling edge without impact to t_{ELQV} .
3. Sampled, not 100% tested.
4. Address hold in synchronous burst mode is t_{CHAX} or t_{VHAX} , whichever timing specification is satisfied first.
5. Synchronous read mode is not supported with TTL level inputs.
6. Applies only to subsequent synchronous reads.

Figure 21: Asynchronous Single-Word Read (ADV# Low)

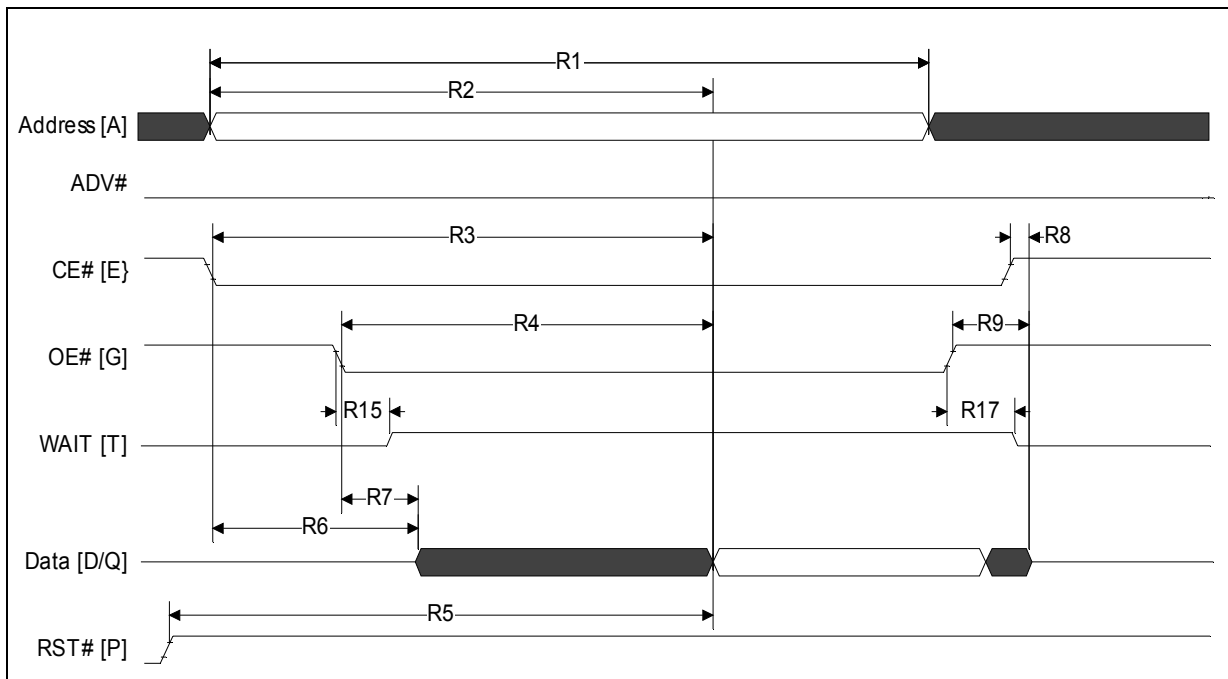

Note: WAIT shown deasserted during asynchronous read mode (RCR.10=0, WAIT asserted low).

Figure 22: Asynchronous Single-Word Read (ADV# Latch)

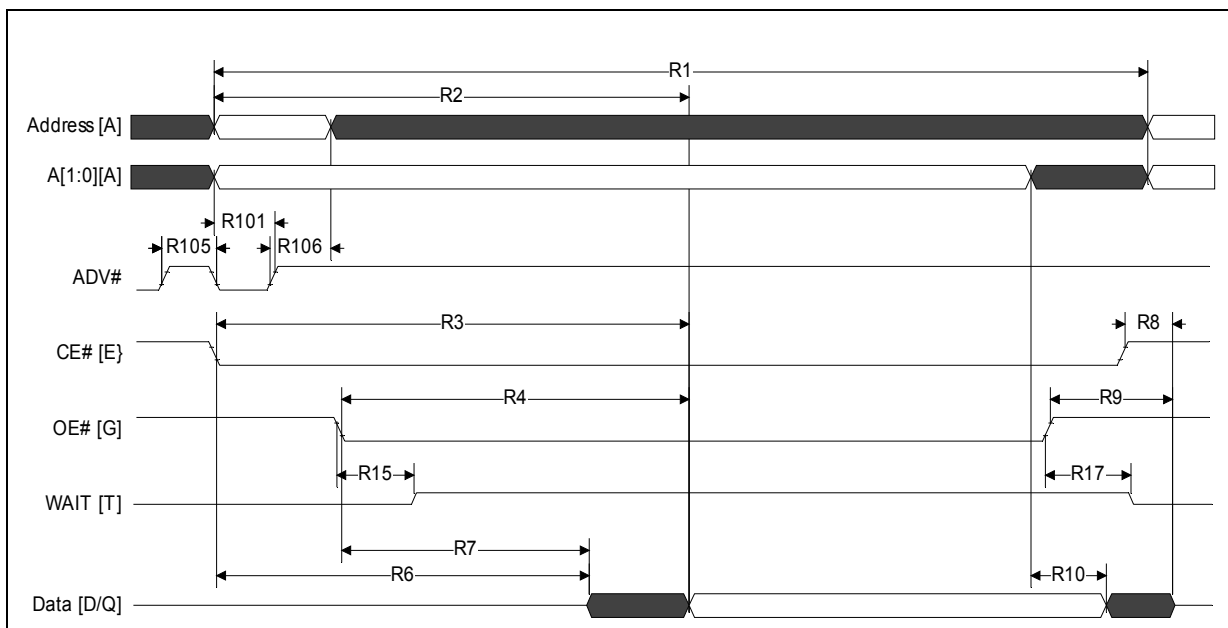

Note: WAIT shown deasserted during asynchronous read mode (RCR.10=0, WAIT asserted low).

Figure 23: Asynchronous Page-Mode Read Timing

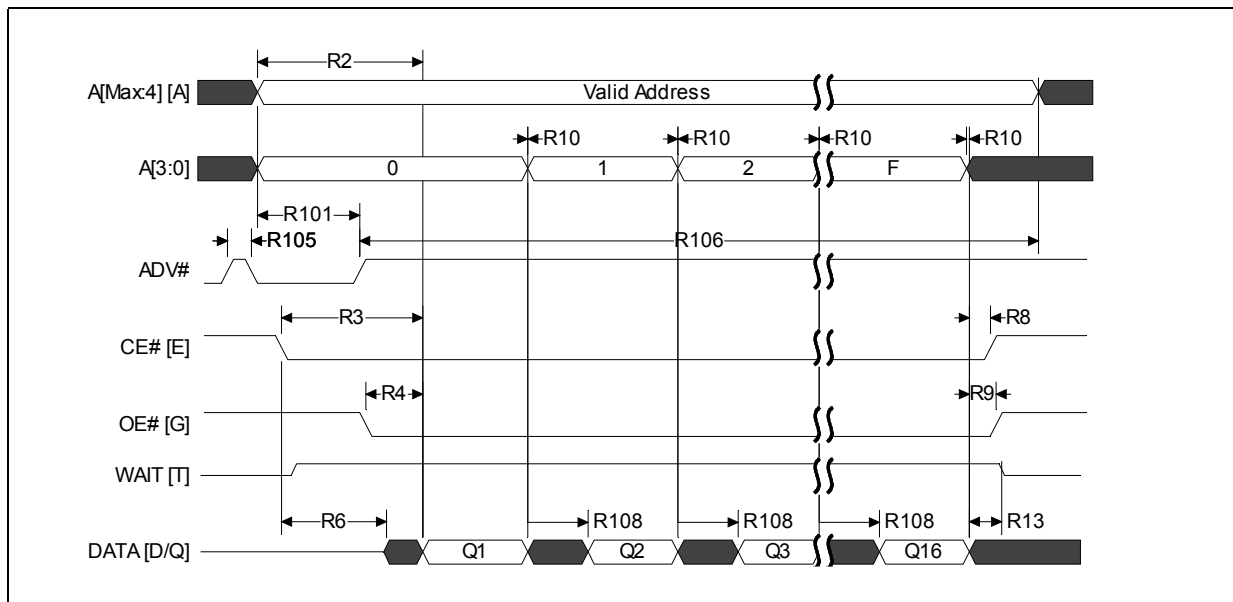

Note: WAIT shown deasserted during asynchronous read mode (RCR.10=0, WAIT asserted low).

Figure 24: Synchronous Single-Word Array or Non-array Read Timing

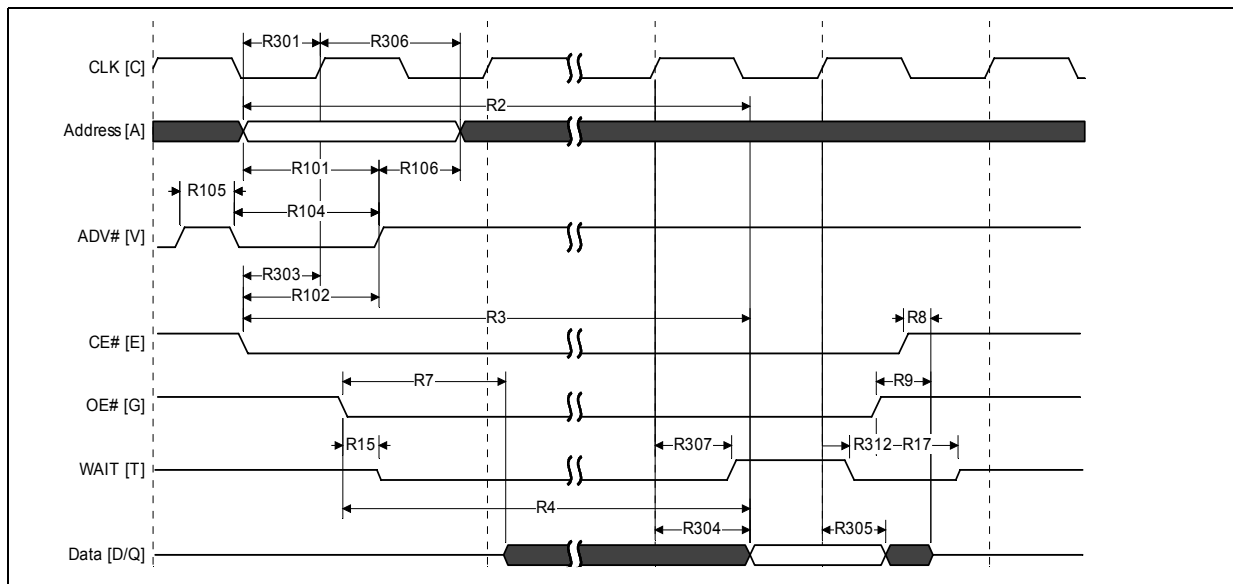

1. WAIT is driven per OE# assertion during synchronous array or non-array read, and can be configured to assert either during or one data cycle before valid data.
2. This diagram illustrates the case in which an n-word burst is initiated to the flash memory array and it is terminated by CE# deassertion after the first word in the burst.

Figure 25: Continuous Burst Read, Showing An Output Delay Timing

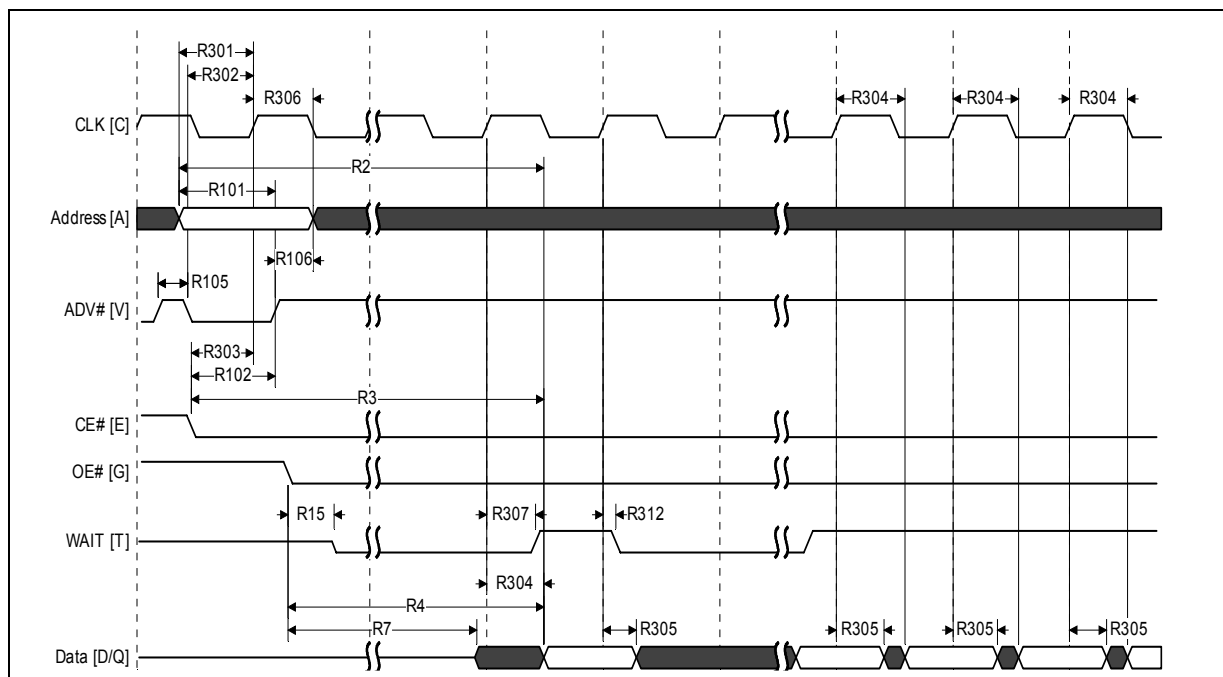

Notes:

1. WAIT is driven per OE# assertion during synchronous array or non-array read, and can be configured to assert either during or one data cycle before valid data.
2. At the end of Word Line; the delay incurred when a burst access crosses a 16-word boundary and the starting address is not 4-word boundary aligned.

Figure 26: Synchronous Burst-Mode Four-Word Read Timing

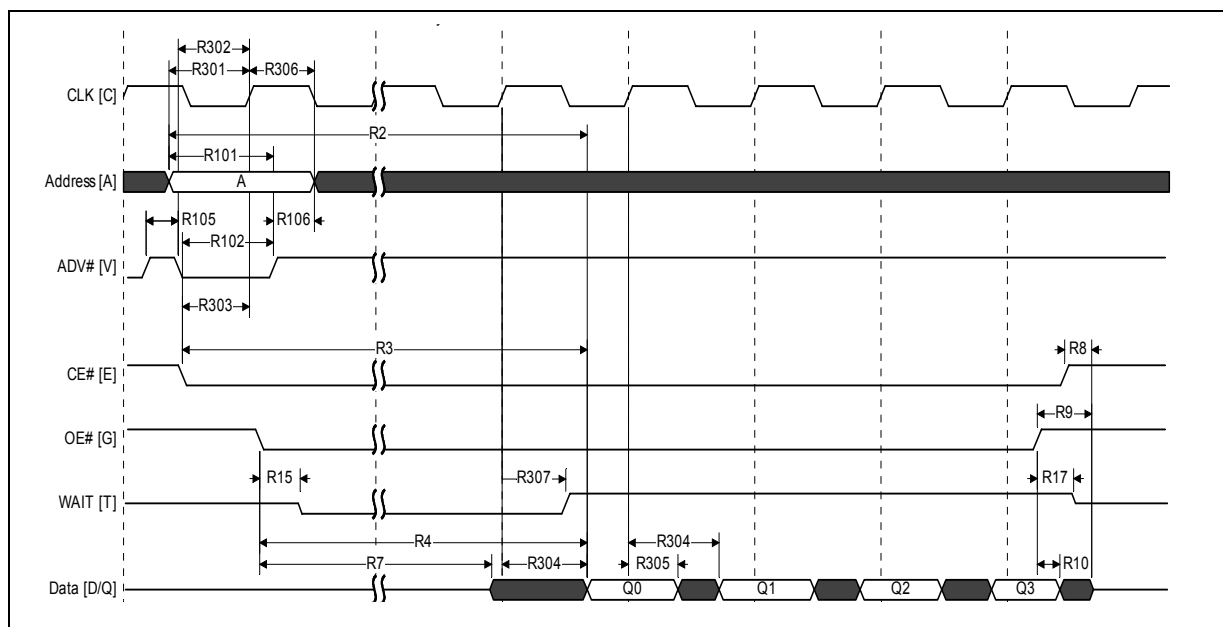

Note: WAIT is driven per OE# assertion during synchronous array or non-array read. WAIT asserted during initial latency and deasserted during valid data (RCR.10 = 0, WAIT asserted low).

15.4 AC Write Specifications

Table 28: AC Write Specifications

Num	Symbol	Parameter	Min	Max	Unit	Notes
W1	t_{PHWL}	RST# high recovery to WE# low	150	-	ns	1,2,3
W2	t_{ELWL}	CE# setup to WE# low	0	-	ns	1,2,3
W3	t_{WLWH}	WE# write pulse width low	50	-	ns	1,2,4
W4	t_{DVWH}	Data setup to WE# high	50	-	ns	1, 2, 12
W5	t_{AVWH}	Address setup to WE# high	50	-	ns	1,2
W6	t_{WHEH}	CE# hold from WE# high	0	-	ns	
W7	t_{WHDX}	Data hold from WE# high	0	-	ns	
W8	t_{WHAX}	Address hold from WE# high	0	-	ns	
W9	t_{WHWL}	WE# pulse width high	20	-	ns	1,2,5
W10	t_{VPWH}	V _{pp} setup to WE# high	200	-	ns	1,2,3,7
W11	t_{QVVL}	V _{pp} hold from Status read	0	-	ns	
W12	t_{QVBL}	WP# hold from Status read	0	-	ns	1,2,3,7
W13	t_{BHWH}	WP# setup to WE# high	200	-	ns	
W14	t_{WHGL}	WE# high to OE# low	0	-	ns	1,2,9
W16	t_{WHQV}	WE# high to read valid	$t_{AVQV} + 35$	-	ns	1,2,3,6,10
Write to Asynchronous Read Specifications						
W18	t_{WHAV}	WE# high to Address valid	0	-	ns	1,2,3,6,8
Write to Synchronous Read Specifications						
W19	$t_{WHCH/L}$	WE# high to Clock valid	19	-	ns	1,2,3,6,10
W20	t_{WHVH}	WE# high to ADV# high	19	-	ns	
W28	t_{WHVL}	WE# high to ADV# low	7	-	ns	
Write Specifications with Clock Active						
W21	t_{VHWL}	ADV# high to WE# low	-	20	ns	1,2,3,11
W22	t_{CHWL}	Clock high to WE# low	-	20	ns	

Notes:

- Write timing characteristics during erase suspend are the same as write-only operations.
- A write operation can be terminated with either CE# or WE#.
- Sampled, not 100% tested.
- Write pulse width low (t_{WLWH} or t_{ELEH}) is defined from CE# or WE# low (whichever occurs last) to CE# or WE# high (whichever occurs first). Hence, $t_{WLWH} = t_{ELEH} = t_{WLEH} = t_{ELWH}$.
- Write pulse width high (t_{WHWL} or t_{EHEL}) is defined from CE# or WE# high (whichever occurs first) to CE# or WE# low (whichever occurs last). Hence, $t_{WHWL} = t_{EHEL} = t_{WHEL} = t_{EHWL}$.
- t_{WHVH} or $t_{WHCH/L}$ must be met when transiting from a write cycle to a synchronous burst read.
- V_{pp} and WP# should be at a valid level until erase or program success is determined.
- This specification is only applicable when transiting from a write cycle to an asynchronous read. See spec W19 and W20 for synchronous read.
- When doing a Read Status operation following any command that alters the Status Register, W14 is 20 ns.
- Add 10 ns if the write operation results in a RCR or block lock status change, for the subsequent read operation to reflect this change.
- These specs are required only when the device is in a synchronous mode and clock is active during address setup phase.
- This specification must be complied with by customer's writing timing. The result would be unpredictable if any violation to this timing specification.

Figure 27: Write-to-Write Timing

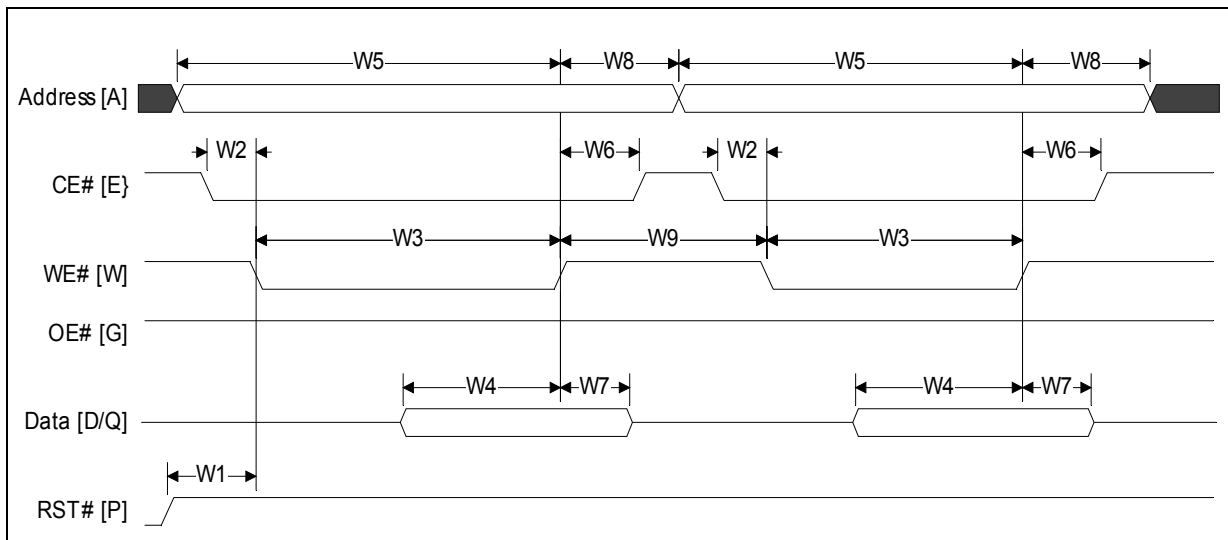
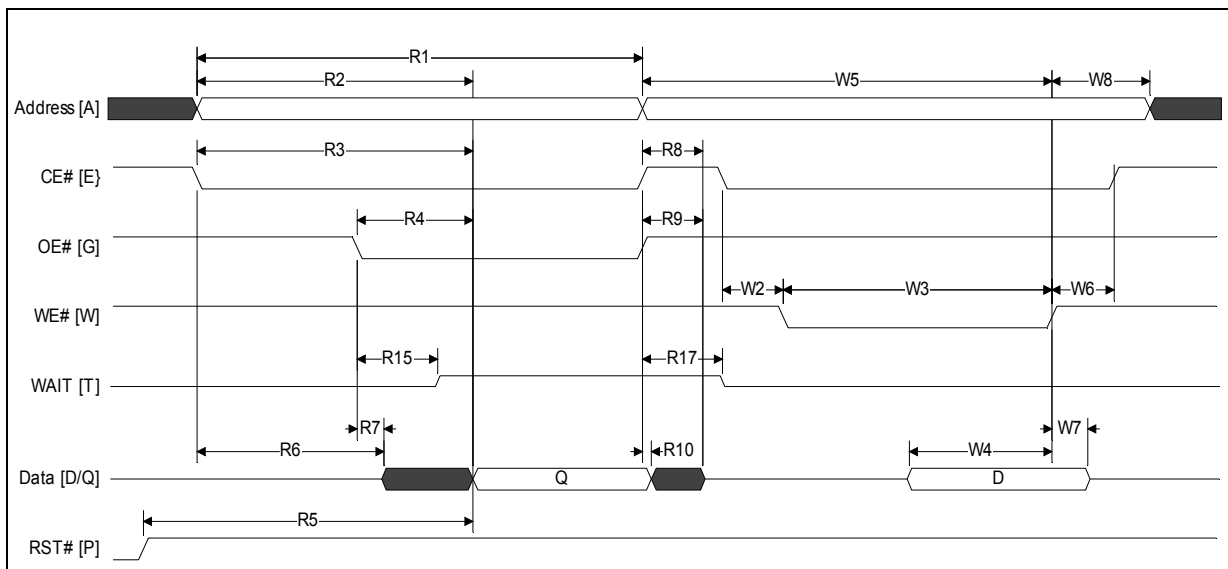

Figure 28: Asynchronous Read-to-Write Timing



Note: WAIT deasserted during asynchronous read and during write. WAIT High-Z during write per OE# deasserted.

Figure 29: Write-to-Asynchronous Read Timing

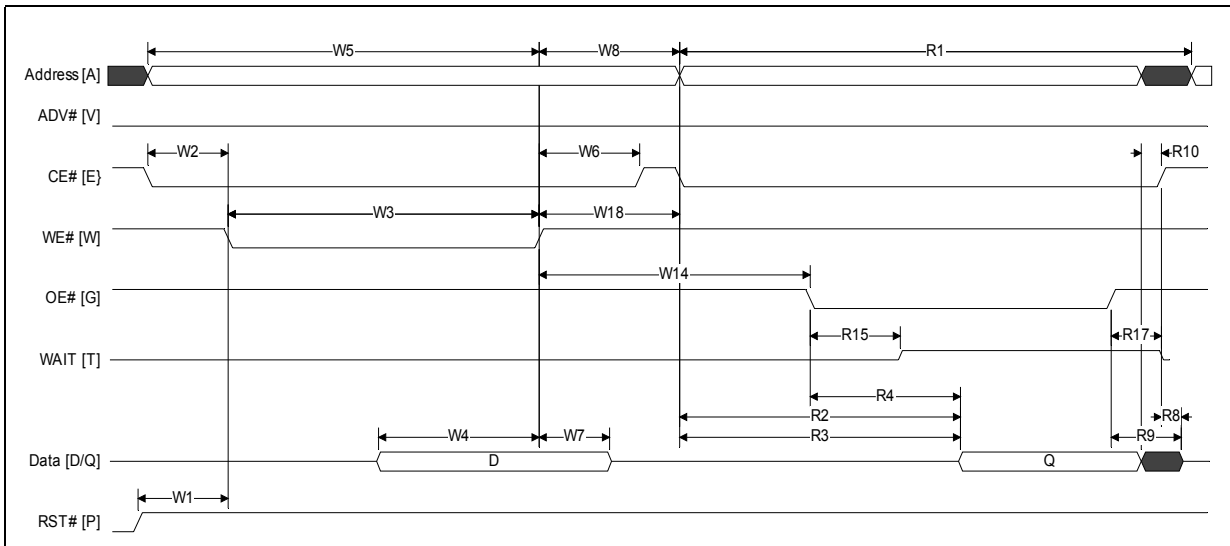
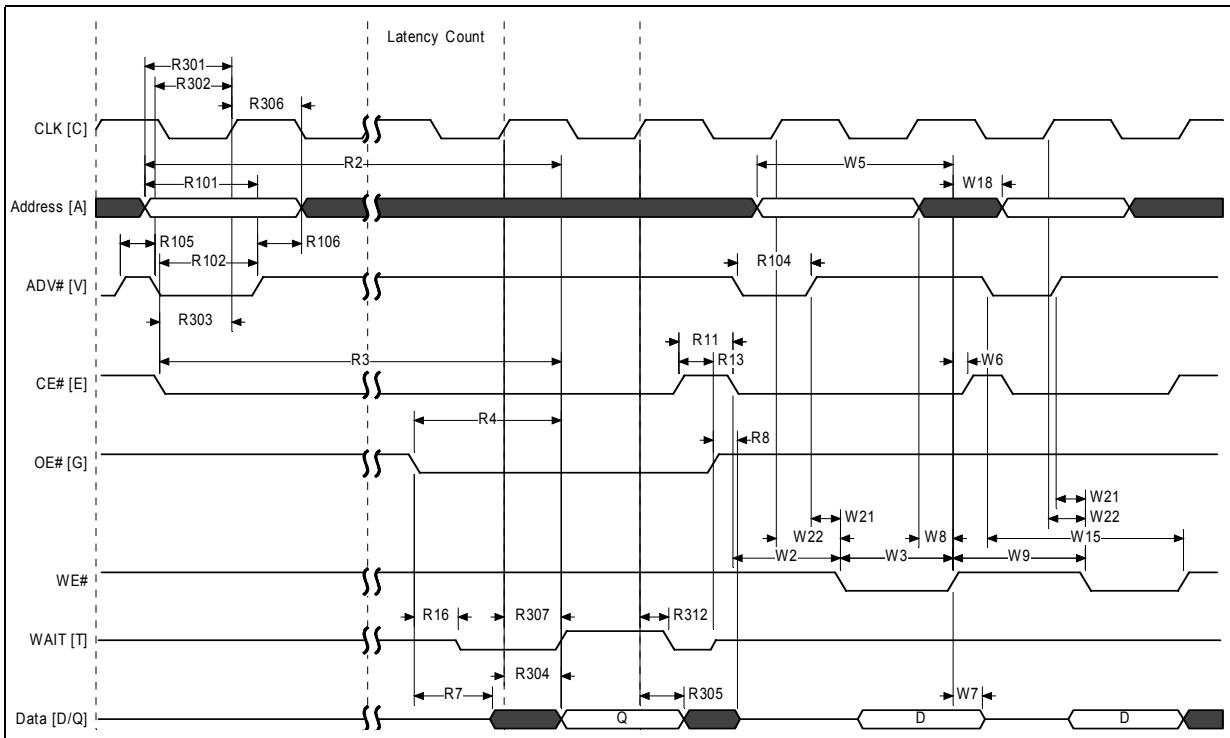
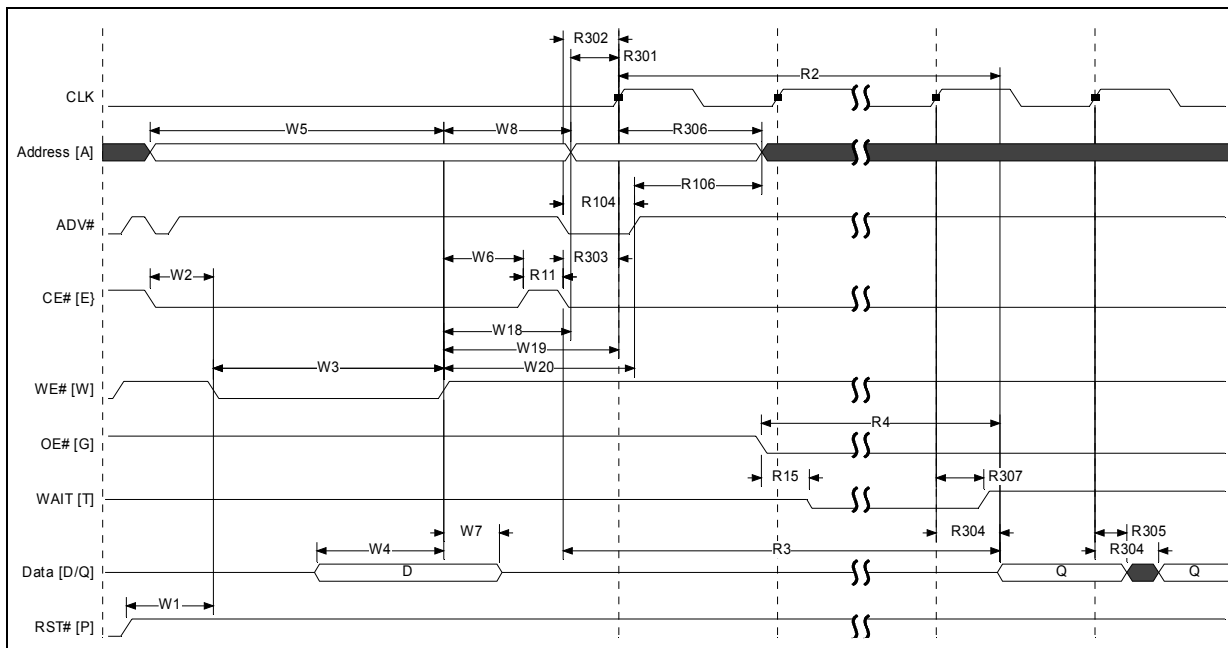

Figure 30: Synchronous Read-to-Write Timing



Note: WAIT shown deasserted and High-Z per OE# deassertion during write operation (RCR.10=0, WAIT asserted low). Clock is ignored during write operation.

Figure 31: Write-to-Synchronous Read Timing



Note: WAIT shown deasserted and High-Z per OE# deassertion during write operation (RCR.10=0, WAIT asserted low).

16.0 Program and Erase Characteristics

Table 29: Program and Erase Specifications

Num	Symbol	Parameter	V _{PPL}			V _{PPH}			Unit	Notes	
			Min	Typ	Max	Min	Typ	Max			
Conventional Word Programming											
W200	t _{PROG/W}	Program Time	Single word	-	270	456	-	270	456	μs	1
Buffered Programming											
W250	t _{PROG}	Program Time	Aligned 32-Word, BP time (32 words)	-	310	716	-	310	716	μs	1
			Aligned 64-Wd, BP time (64 words)	-	310	900	-	310	900		
			Aligned 128-Wd, BP time (128 words)	-	375	1140	-	375	1140		
			Aligned 256-Wd, BP time (256 words)	-	505	1690	-	505	1690		
			one full buffer, BP time (512 words)	-	900	3016	-	900	3016		
Buffered Enhanced Factory Programming											
W451	t _{BEFP/B}	Program	Single byte	n/a	n/a	n/a	-	0.5	-	μs	1,2
W452	t _{BEFP/Setup}		BEFP Setup	n/a	n/a	n/a	5	-	-		1
Erase and Suspend											
W500	t _{ERS/PB}	Erase Time	32-KByte Parameter	-	0.8	4.0	-	0.8	4.0	s	1
W501	t _{ERS/MB}		128-KByte Main	-	0.8	4.0	-	0.8	4.0		
W600	t _{SUSP/P}	Suspend Latency	Program suspend	-	25	30	-	25	30	μs	
W601	t _{SUSP/E}		Erase suspend	-	25	30	-	25	30		
W602	t _{ERS/SUSP}		Erase to Suspend	-	500	-	-	500	-		1,3
blank check											
W702	t _{BC/MB}	blank check	Main Array Block	-	3.2	-	-	3.2	-	ms	

Notes:

1. Typical values measured at T_C = +25 °C and nominal voltages. Performance numbers are valid for all speed versions. Excludes system overhead. Sampled, but not 100% tested.
2. Averaged over entire device.
3. W602 is the typical time between an initial block erase or erase resume command and the a subsequent erase suspend command. Violating the specification repeatedly during any particular block erase may cause erase failures.

17.0 Ordering Information

17.1 Discrete Products

Figure 32: Decoder for Discrete P30-65nm

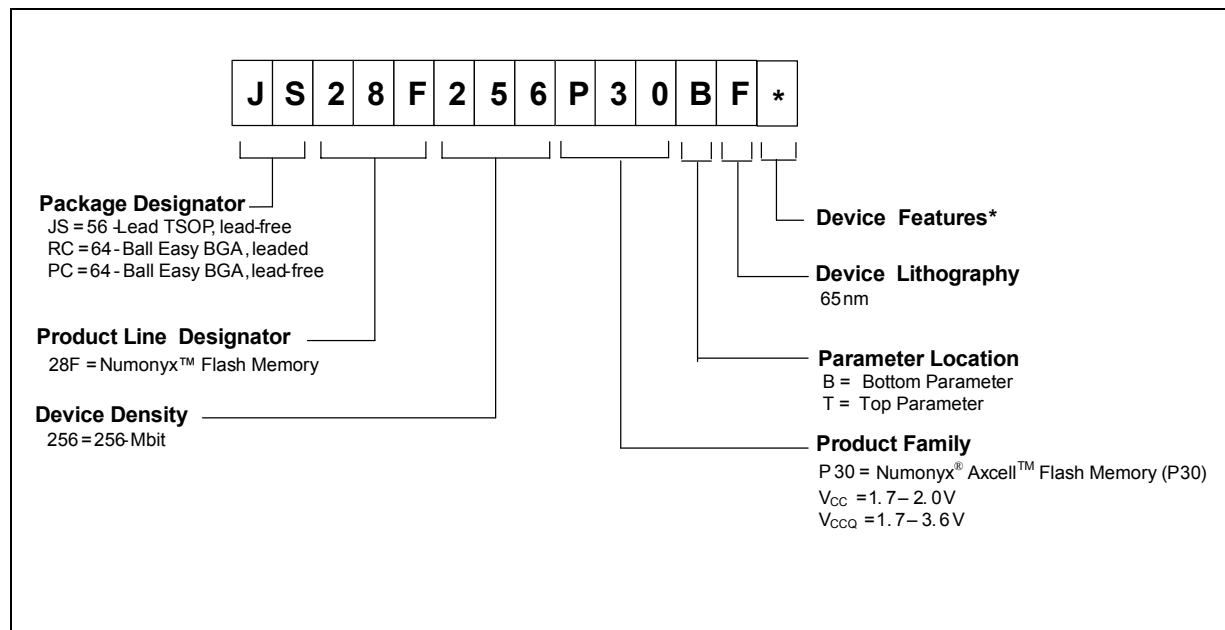

Note: The last digit is randomly assigned to cover packing media and/or features or other specific configuration.

Table 30: Valid Combinations for Discrete Products

256-Mbit
JS28F256P30BF*
JS28F256P30TF*
RC28F256P30BF*
RC28F256P30TF*
PC28F256P30BF*
PC28F256P30TF*

17.2 SCSP Products

Figure 33: Decoder for SCSP P30-65nm

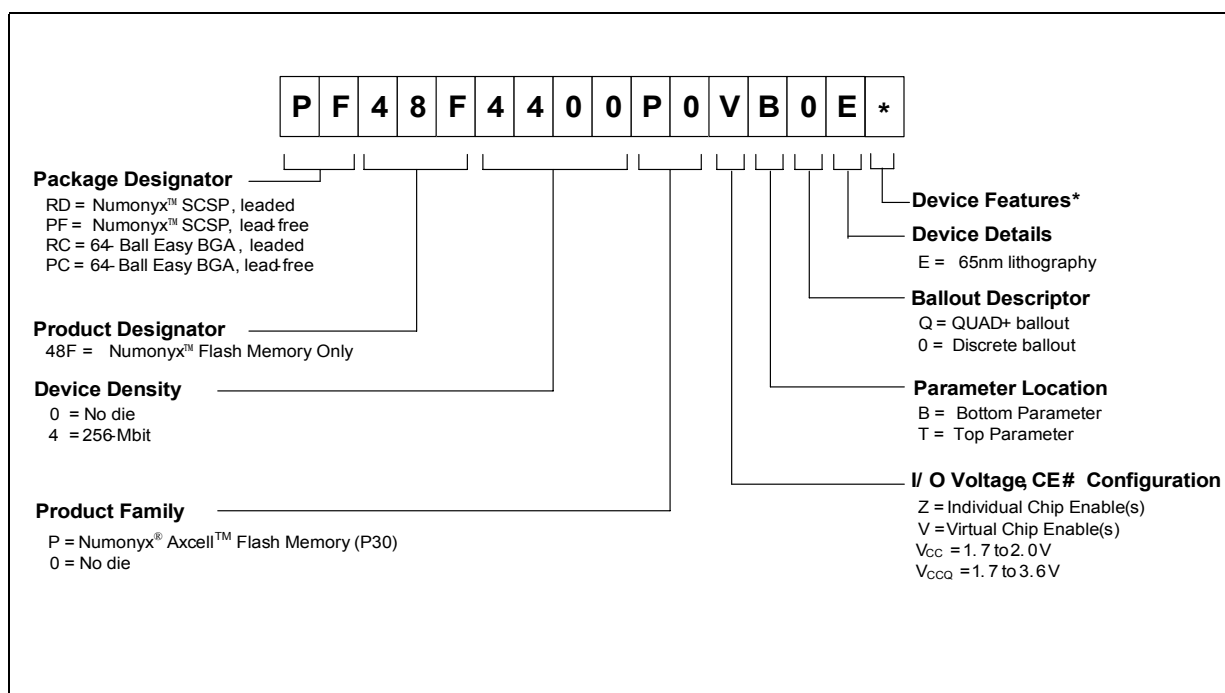

Note: The last digit is randomly assigned to cover packing media and/or features or other specific configuration.

Table 31: Valid Combinations for Dual-Die Products

256-Mbit	512-Mbit*
	RD48F4400P0VBQE*
PF48F4000P0ZBQE*	PF48F4400P0VBQE*
PF48F4000P0ZTQE*	RC48F4400P0VB0E*
	PC48F4400P0VB0E*

Note: The "B" parameter is used for Top(Die1)/Bot(Die2) stack option in the 512-Mbit density.

Appendix A Supplemental Reference Information

A.1 Common Flash Interface Tables

The Common Flash Interface (CFI) is part of an overall specification for multiple command-set and control-interface descriptions. This appendix describes the database structure containing the data returned by a read operation after issuing the Read CFI command (see [Section 6.0, "Command Set" on page 21](#)). System software can parse this database structure to obtain information about the flash device, such as block size, density, bus width, and electrical specifications. The system software will then know which command set(s) to use to properly perform flash writes, block erases, reads and otherwise control the flash device.

A.1.1 CFI Structure Output

The CFI database allows system software to obtain information for controlling the flash device. This section describes the device's CFI-compliant interface that allows access to CFI data.

CFI data are presented on the lowest-order data outputs (DQ₇₋₀) only. The numerical offset value is the address relative to the maximum bus width supported by the device. On this family of devices, the CFI table device starting address is a 10h, which is a word address for x16 devices.

For a word-wide (x16) device, the first two CFI-structure bytes, ASCII "Q" and "R," appear on the low byte at word addresses 10h and 11h. This CFI-compliant device outputs 00h data on upper bytes. The device outputs ASCII "Q" in the low byte (DQ₇₋₀) and 00h in the high byte (DQ₁₅₋₈).

At CFI addresses containing two or more bytes of information, the least significant data byte is presented at the lower address, and the most significant data byte is presented at the higher address.

In all of the following tables, addresses and data are represented in hexadecimal notation, so the "h" suffix has been dropped. In addition, since the upper byte of word-wide devices is always "00h," the leading "00" has been dropped from the table notation and only the lower byte value is shown. Any x16 device outputs can be assumed to have 00h on the upper byte in this mode.

Table 32: Summary of CFI Structure Output as a Function of Device and Mode

Device	Hex Offset	Hex Code	ASCII Value
Device Addresses	00010:	51	"Q"
	00011:	52	"R"
	00012:	59	"Y"

Table 33: Example of CFI Structure Output of x16 Devices

Offset	Hex Code	Value
A_x-A_1	$D_{15}-D_0$	
00010h	0051	"Q"
00011h	0052	"R"
00012h	0059	"Y"
00013h	P_ID _{LO}	PrVendor ID#
00014h	P_ID _{HI}	
00015h	P _{LO}	PrVendor TblAdr
00016h	P _{HI}	
00017h	A_ID _{LO}	AltVendor ID#
00018h	A_ID _{HI}	
...

A.1.2 CFI Structure Overview

The CFI command causes the flash component to display the Common Flash Interface (CFI) structure or "database." The structure sub-sections and address locations are summarized below.

Table 34: CFI Structure

00001-Fh	Reserved	Reserved for vendor-specific information
00010h	CFI query identification string	Command set ID and vendor data offset
0001Bh	System interface information	Device timing & voltage information
00027h	Device geometry definition	Flash device layout
P ⁽³⁾	Primary Numonyx-specific Extended Query Table	Vendor-defined additional information specific to the Primary Vendor Algorithm

Notes:

1. Refer to the CFI Structure Output section and offset 28h for the detailed definition of offset address as a function of device bus width and mode.
2. BA = Block Address beginning location (i.e., 08000h is block 1's beginning location when the block size is 32-KWord).
3. Offset 15 defines "P" which points to the Primary Numonyx-specific Extended CFI Table.

A.1.3 Read CFI Identification String

The Identification String provides verification that the component supports the Common Flash Interface specification. It also indicates the specification version and supported vendor-specified command set(s).

Table 35: CFI Identification

Offset	Length	Description	Add.	Hex Code	Value
10h	3	Query-unique ASCII string "QRY"	10: 11: 12:	--51 --52 --59	"Q" "R" "Y"
13h	2	Primary vendor command set and control interface ID code. 16-bit ID code for vendor-specified algorithms	13: 14:	--01 --00	
15h	2	Extended Query Table primary algorithm address	15: 16:	--0A --01	
17h	2	Alternate vendor command set and control interface ID code. 0000h means no second vendor-specified algorithm exists	17: 18:	--00 --00	
19h	2	Secondary algorithm Extended Query Table address. 0000h means none exists	19: 1A:	--00 --00	

A.1.4 Device Geometry Definition

Table 36: System Interface Information

Offset	Length	Description	Add	Hex Code	Value
1Bh	1	VCC logic supply minimum program/erase voltage bits 0-3 BCD 100 mV bits 4-7 BCD volts	1B:	--17	1.7V
1Ch	1	VCC logic supply maximum program/erase voltage bits 0-3 BCD 100 mV bits 4-7 BCD volts	1C:	--20	2.0V
1Dh	1	VPP [programming] supply minimum program/erase voltage bits 0-3 BCD 100 mV bits 4-7 HEX volts	1D:	--85	8.5V
1Eh	1	VPP [programming] supply maximum program/erase voltage bits 0-3 BCD 100 mV bits 4-7 HEX volts	1E:	--95	9.5V
1Fh	1	"n" such that typical single word program time-out = 2^n μ -sec	1F:	--09	512 μ s
20h	1	"n" such that typical full buffer write time-out = 2^n μ -sec	20:	--0A	1024 μ s
21h	1	"n" such that typical block erase time-out = 2^n m-sec	21:	--0A	1s
22h	1	"n" such that typical full chip erase time-out = 2^n m-sec	22:	--00	NA
23h	1	"n" such that maximum word program time-out = 2^n times typical	23:	--01	1024 μ s
24h	1	"n" such that maximum buffer write time-out = 2^n times typical	24:	--02	4096 μ s
25h	1	"n" such that maximum block erase time-out = 2^n times typical	25:	--02	4s
26h	1	"n" such that maximum chip erase time-out = 2^n times typical	26:	--00	NA

Table 37: Device Geometry Definition

Offset	Length	Description	Add.	Hex Code	Value																																
27h	1	"n" such that device size = 2 ⁿ in number of bytes	27:	See table below																																	
28h	2	Flash device interface code assignment: "n" such that n+1 specifies the bit field that represents the flash device width capabilities as described in the table:	28:	--01	x16																																
		<table border="1" style="width: 100%; text-align: center;"> <tr> <td>7</td><td>6</td><td>5</td><td>4</td><td>3</td><td>2</td><td>1</td><td>0</td> </tr> <tr> <td>—</td><td>—</td><td>—</td><td>—</td><td>x64</td><td>x32</td><td>x16</td><td>x8</td> </tr> <tr> <td>15</td><td>14</td><td>13</td><td>12</td><td>11</td><td>10</td><td>9</td><td>8</td> </tr> <tr> <td>—</td><td>—</td><td>—</td><td>—</td><td>—</td><td>—</td><td>—</td><td>—</td> </tr> </table>				7	6	5	4	3	2	1	0	—	—	—	—	x64	x32	x16	x8	15	14	13	12	11	10	9	8	—	—	—	—	—	—	—	—
		7				6	5	4	3	2	1	0																									
—	—	—	—	x64	x32	x16	x8																														
15	14	13	12	11	10	9	8																														
—	—	—	—	—	—	—	—																														
29:	--00																																				
2Ah	2	"n" such that maximum number of bytes in write buffer = 2 ⁿ	2A:	--0A	1024																																
			2B:	--00																																	
2Ch	1	Number of erase block regions (x) within device: 1. x = 0 means no erase blocking; the device erases in bulk 2. x specifies the number of device regions with one or more contiguous same-size erase blocks. 3. Symmetrically blocked partitions have one blocking region	2C:	See table below																																	
2Dh	4	Erase Block Region 1 Information bits 0–15 = y, y+1 = number of identical-size erase blocks bits 16–31 = z, region erase block(s) size are z x 256 bytes	2D:	See table below																																	
			2E:																																		
			2F:																																		
31h	4	Erase Block Region 2 Information bits 0–15 = y, y+1 = number of identical-size erase blocks bits 16–31 = z, region erase block(s) size are z x 256 bytes	31:	See table below																																	
			32:																																		
			33:																																		
35h	4	Reserved for future erase block region information	34:	See table below																																	
			35:																																		
			36:																																		
			37:																																		
			38:																																		

Address	256-Mbit		Address	256-Mbit	
	-B	-T		-B	-T
27:	--19	--19	30:	--00	--02
28:	--01	--01	31:	--FE	--03
29:	--00	--00	32:	--00	--00
2A:	--0A	--0A	33:	--00	--80
2B:	--00	--00	34:	--02	--00
2C:	--02	--02	35:	--00	--00
2D:	--03	--FE	36:	--00	--00
2E:	--00	--00	37:	--00	--00
2F:	--80	--00	38:	--00	--00

A.1.5 Numonyx-Specific Extended CFI Table

Table 38: Primary Vendor-Specific Extended CFI

Offset ⁽¹⁾ P = 10Ah	Length	Description (Optional flash features and commands)	Add.	Hex Code	Value
(P+0)h (P+1)h (P+2)h	3	Primary extended query table Unique ASCII string "PR"	10A: 10B: 10C:	--50 --52 --49	"P" "R" "I"
(P+3)h	1	Major version number, ASCII	10D:	--31	"1"
(P+4)h	1	Minor version number, ASCII	10E:	--34	"4"
(P+5)h (P+6)h (P+7)h (P+8)h	4	Optional feature and command support (1=yes, 0=no) <i>bits 11–29 are reserved; undefined bits are "0." If bit 31 is "1" then another 31 bit field of Optional features follows at the end of the bit–30 field.</i> bit 0 Chip erase supported bit 1 Suspend erase supported bit 2 Suspend program supported bit 3 Legacy lock/unlock supported bit 4 Queued erase supported bit 5 Instant individual block locking supported bit 6 Protection bits supported bit 7 Pagemode read supported bit 8 Synchronous read supported bit 9 Simultaneous operations supported bit 10 Extended Flash Array Blocks supported bit 30 CFI Link(s) to follow bit 31 Another "Optional Features" field to follow	10F: 110: 111: 112:	--E6 --01 --00 See table below	 No Yes Yes No No Yes Yes Yes Yes No No See table below
(P+9)h	1	Supported functions after suspend: read Array, Status, Query Other supported operations are: bits 1–7 reserved; undefined bits are "0" bit 0 Program supported after erase suspend	113:	--01	 Yes
(P+A)h (P+B)h	2	Block status register mask <i>bits 2–15 are Reserved; undefined bits are "0"</i> bit 0 Block Lock-Bit Status register active bit 1 Block Lock-Dow n Bit Status active bit 4 EFA Block Lock-Bit Status register active bit 5 EFA Block Lock-Dow n Bit Status active	114: 115:	--03 --00	 Yes Yes No No
(P+C)h	1	V _{CC} logic supply highest performance program/erase voltage bits 0–3 BCD value in 100 mV bits 4–7 BCD value in volts	116:	--18	1.8V
(P+D)h	1	V _{PP} optimum program/erase supply voltage bits 0–3 BCD value in 100 mV bits 4–7 HEX value in volts	117:	--90	9.0V

Address	Discrete		512-Mbit			
	-B	-T	-B		-T	
	—	—	die 1 (B)	die 2 (T)	die 1 (T)	die 2 (B)
112:	--00	--00	--40	--00	--40	--00

Table 39: Protection Register Information

Offset ⁽¹⁾ P = 10Ah	Length	Description (Optional flash features and commands)	Add.	Hex Code	Value
(P+E)h	1	Number of Protection register fields in JEDEC ID space. "00h," indicates that 256 protection fields are available	118:	--02	2
(P+F)h (P+10)h (P+11)h (P+12)h	4	Protection Field 1: Protection Description This field describes user-available One Time Programmable (OTP) Protection register bytes. Some are pre-programmed with device-unique serial numbers. Others are user programmable. Bits 0–15 point to the Protection register Lock byte, the section's first byte. The following bytes are factory pre-programmed and user-programmable. bits 0–7 = Lock/bytes Jedec-plane physical low address bits 8-15 = Lock/bytes Jedec-plane physical high address bits 16-23 = "n" such that 2 ⁿ =factory pre-programmed bytes bits 24-31 = "n" such that 2 ⁿ =user programmable bytes	119: 11A: 11B: 11C:	--80 --00 --03 --03	80h 00h 8 byte 8 byte
(P+13)h (P+14)h (P+15)h (P+16)h (P+17)h (P+18)h (P+19)h (P+1A)h (P+1B)h (P+1C)h	10	Protection Field 2: Protection Description Bits 0–31 point to the Protection register physical Lock-word address in the Jedec-plane. Following bytes are factory or user-programmable. bits 32–39 = "n" such that n = factory pgm'd groups (low byte) bits 40–47 = "n" such that n = factory pgm'd groups (high byte) bits 48–55 = "n" \ 2n = factory programmable bytes/group bits 56–63 = "n" such that n = user pgm'd groups (low byte) bits 64–71 = "n" such that n = user pgm'd groups (high byte) bits 72–79 = "n" such that 2 ⁿ = user programmable bytes/group	11D: 11E: 11F: 120: 121: 122: 123: 124: 125: 126:	--89 --00 --00 --00 --00 --00 --00 --10 --00 --04	89h 00h 00h 00h 0 0 0 16 0 16

Figure 34: Burst Read Information

Offset ⁽¹⁾ P = 10Ah	Length	Description (Optional flash features and commands)	Add.	Hex Code	Value
(P+1D)h	1	Page Mode Read capability bits 0–7 = “n” such that 2 ⁿ HEX value represents the number of read-page bytes. See offset 28h for device word width to determine page-mode data output width. 00h indicates no read page buffer.	127:	--05	32 byte
(P+1E)h	1	Number of synchronous mode read configuration fields that follow. 00h indicates no burst capability.	128:	--04	4
(P+1F)h	1	Synchronous mode read capability configuration 1 Bits 3–7 = Reserved bits 0–2 “n” such that 2 ⁿ⁺¹ HEX value represents the maximum number of continuous synchronous reads when the device is configured for its maximum word width. A value of 07h indicates that the device is capable of continuous linear bursts that will output data until the internal burst counter reaches the end of the device's burstable address space. This field's 3-bit value can be written directly to the Read Configuration Register bits 0-2 if the device is configured for its maximum word width. See offset 28h for word width to determine the burst data output width.	129:	--01	4
(P+20)h	1	Synchronous mode read capability configuration 2	12A:	--02	8
(P+21)h	1	Synchronous mode read capability configuration 3	12B:	--03	16
(P+22)h	1	Synchronous mode read capability configuration 4	12C:	--07	Cont

Table 40: Partition and Erase Block Region Information

Offset ⁽¹⁾ P = 10Ah		Description (Optional flash features and commands)	See table below		
Bottom	Top		Len	Address	
				Bot	Top
(P+23)h	(P+23)h	Number of device hardware-partition regions within the device. x = 0: a single hardware partition device (no fields follow). x specifies the number of device partition regions containing one or more contiguous erase block regions.	1	12D:	12D:

Table 41: Partition Region 1 Information

Offset ⁽¹⁾ P = 10Ah		Description (Optional flash features and commands)	See table below		
Bottom	Top		Len	Address	
				Bot	Top
(P+24)h	(P+24)h	Data size of this Partition Region Information field	2	12E:	12E:
(P+25)h	(P+25)h	(# addressable locations, including this field)		12F:	12F:
(P+26)h	(P+26)h	Number of identical partitions within the partition region	2	130:	130:
(P+27)h	(P+27)h			131:	131:
(P+28)h	(P+28)h	Number of program or erase operations allowed in a partition bits 0–3 = number of simultaneous Program operations bits 4–7 = number of simultaneous Erase operations	1	132:	132:
(P+29)h	(P+29)h	Simultaneous program or erase operations allowed in other partitions while a partition in this region is in Program mode bits 0–3 = number of simultaneous Program operations bits 4–7 = number of simultaneous Erase operations	1	133:	133:
(P+2A)h	(P+2A)h	Simultaneous program or erase operations allowed in other partitions while a partition in this region is in Erase mode bits 0–3 = number of simultaneous Program operations bits 4–7 = number of simultaneous Erase operations	1	134:	134:
(P+2B)h	(P+2B)h	Types of erase block regions in this Partition Region. x = 0 = no erase blocking; the Partition Region erases in bulk x = number of erase block regions w/ contiguous same-size erase blocks. Symmetrically blocked partitions have one blocking region. Partition size = (Type 1 blocks)x(Type 1 block sizes) + (Type 2 blocks)x(Type 2 block sizes)+...+(Type n blocks)x(Type n block sizes)	1	135:	135:

Table 42: Partition Region 1 Information (continued)

Offset ⁽¹⁾ P = 10Ah		Description (Optional flash features and commands)	See table below		
Bottom	Top		Len	Address	
				Bot	Top
(P+2C)h (P+2D)h (P+2E)h (P+2F)h	(P+2C)h (P+2D)h (P+2E)h (P+2F)h	Partition Region 1 Erase Block Type 1 Information bits 0–15 = y, y+1 = # identical-size erase blks in a partition bits 16–31 = z, region erase block(s) size are z x 256 bytes	4	136: 137: 138: 139:	136: 137: 138: 139:
(P+30)h (P+31)h	(P+30)h (P+31)h	Partition 1 (Erase Block Type 1) Block erase cycles x 1000	2	13A: 13B:	13A: 13B:
(P+32)h	(P+32)h	Partition 1 (erase block Type 1) bits per cell; internal EDAC bits 0–3 = bits per cell in erase region bit 4 = internal EDAC used (1=yes, 0=no) bits 5–7 = reserve for future use	1	13C:	13C:
(P+33)h	(P+33)h	Partition 1 (erase block Type 1) page mode and synchronous mode capabilities defined in Table 10. bit 0 = page-mode host reads permitted (1=yes, 0=no) bit 1 = synchronous host reads permitted (1=yes, 0=no) bit 2 = synchronous host writes permitted	1	13D:	13D:
(P+34)h (P+35)h (P+36)h (P+37)h (P+38)h (P+39)h	(P+34)h (P+35)h (P+36)h (P+37)h (P+38)h (P+39)h	Partition Region 1 (Erase Block Type 1) Programming Region Information bits 0–7 = x, 2 ^x = Programming Region aligned size (bytes) bits 8–14 = Reserved; bit 15 = Legacy flash operation (ignore 0:7) bits 16–23 = y = Control Mode valid size in bytes bits 24–31 = Reserved bits 32–39 = z = Control Mode invalid size in bytes bits 40–46 = Reserved; bit 47 = Legacy flash operation (ignore 23:16 & 39:32)	6	13E: 13F: 140: 141: 142: 143:	13E: 13F: 140: 141: 142: 143:
(P+3A)h (P+3B)h (P+3C)h (P+3D)h	(P+3A)h (P+3B)h (P+3C)h (P+3D)h	Partition Region 1 Erase Block Type 2 Information bits 0–15 = y, y+1 = # identical-size erase blks in a partition bits 16–31 = z, region erase block(s) size are z x 256 bytes	4	144: 145: 146: 147:	144: 145: 146: 147:
(P+3E)h (P+3F)h	(P+3E)h (P+3F)h	Partition 1 (Erase Block Type 2) Block erase cycles x 1000	2	148: 149:	148: 149:
(P+40)h	(P+40)h	Partition 1 (erase block Type 2) bits per cell; internal EDAC bits 0–3 = bits per cell in erase region bit 4 = internal EDAC used (1=yes, 0=no) bits 5–7 = reserve for future use	1	14A:	14A:
(P+41)h	(P+41)h	Partition 1 (erase block Type 2) page mode and synchronous mode capabilities defined in Table 10. bit 0 = page-mode host reads permitted (1=yes, 0=no) bit 1 = synchronous host reads permitted (1=yes, 0=no) bit 2 = synchronous host writes permitted	1	14B:	14B:
(P+42)h (P+43)h (P+44)h (P+45)h (P+46)h (P+47)h	(P+42)h (P+43)h (P+44)h (P+45)h (P+46)h (P+47)h	Partition Region 1 (Erase Block Type 2) Programming Region Information bits 0–7 = x, 2 ^x = Programming Region aligned size (bytes) bits 8–14 = Reserved; bit 15 = Legacy flash operation (ignore 0:7) bits 16–23 = y = Control Mode valid size in bytes bits 24–31 = Reserved bits 32–39 = z = Control Mode invalid size in bytes bits 40–46 = Reserved; bit 47 = Legacy flash operation (ignore 23:16 & 39:32)	6	14C: 14D: 14E: 14F: 150: 151:	14C: 14D: 14E: 14F: 150: 151:

Table 43: Partition and Erase Block Region Information

Partition and Erase-block Region Information

Address	256-Mbit	
	-B	-T
12D:	--01	--01
12E:	--24	--24
12F:	--00	--00
130:	--01	--01
131:	--00	--00
132:	--11	--11
133:	--00	--00
134:	--00	--00
135:	--02	--02
136:	--03	--FE
137:	--00	--00
138:	--80	--00
139:	--00	--02
13A:	--64	--64
13B:	--00	--00
13C:	--02	--02
13D:	--03	--03
13E:	--00	--00
13F:	--80	--80
140:	--00	--00
141:	--00	--00
142:	--00	--00
143:	--80	--80
144:	--FE	--03
145:	--00	--00
146:	--00	--80
147:	--02	--00
148:	--64	--64
149:	--00	--00
14A:	--02	--02
14B:	--03	--03
14C:	--00	--00
14D:	--80	--80
14E:	--00	--00
14F:	--00	--00
150:	--00	--00
151:	--80	--80

Table 44: CFI Link Information

Offset ⁽¹⁾	Len	Description	Add.	Hex Code	Value
P = 10Ah		(Optional flash features and commands)			
(P+48)h (P+49)h (P+4A)h (P+4B)h	4	CFI Link Field bit definitions Bits 0–9 = Address offset (within 32Mbit segment) of referenced CFI table Bits 10–27 = nth 32Mbit segment of referenced CFI table Bits 28–30 = Memory Type Bit 31 = Another CFI Link field immediately follows	152: 153: 154: 155:		See table below
(P+4C)h	1	CFI Link Field Quantity Subfield definitions Bits 0–3 = Quantity field (n such that n+1 equals quantity) Bit 4 = Table & Die relative location Bit 5 = Link Field & Table relative location Bits 6–7 = Reserved	156:		See table below

Address	Discrete		512-Mbit			
	–B	–T	–B		–T	
	--	--	die 1 (B)	die 2 (T)	die 1 (T)	die 2 (B)
152:	--FF	--FF	--10	--FF	--10	--FF
153:	--FF	--FF	--20	--FF	--20	--FF
154:	--FF	--FF	--00	--FF	--00	--FF
155:	--FF	--FF	--00	--FF	--00	--FF
156:	--FF	--FF	--10	--FF	--10	--FF

A.2 Flowcharts

Figure 35: Word Program Flowchart

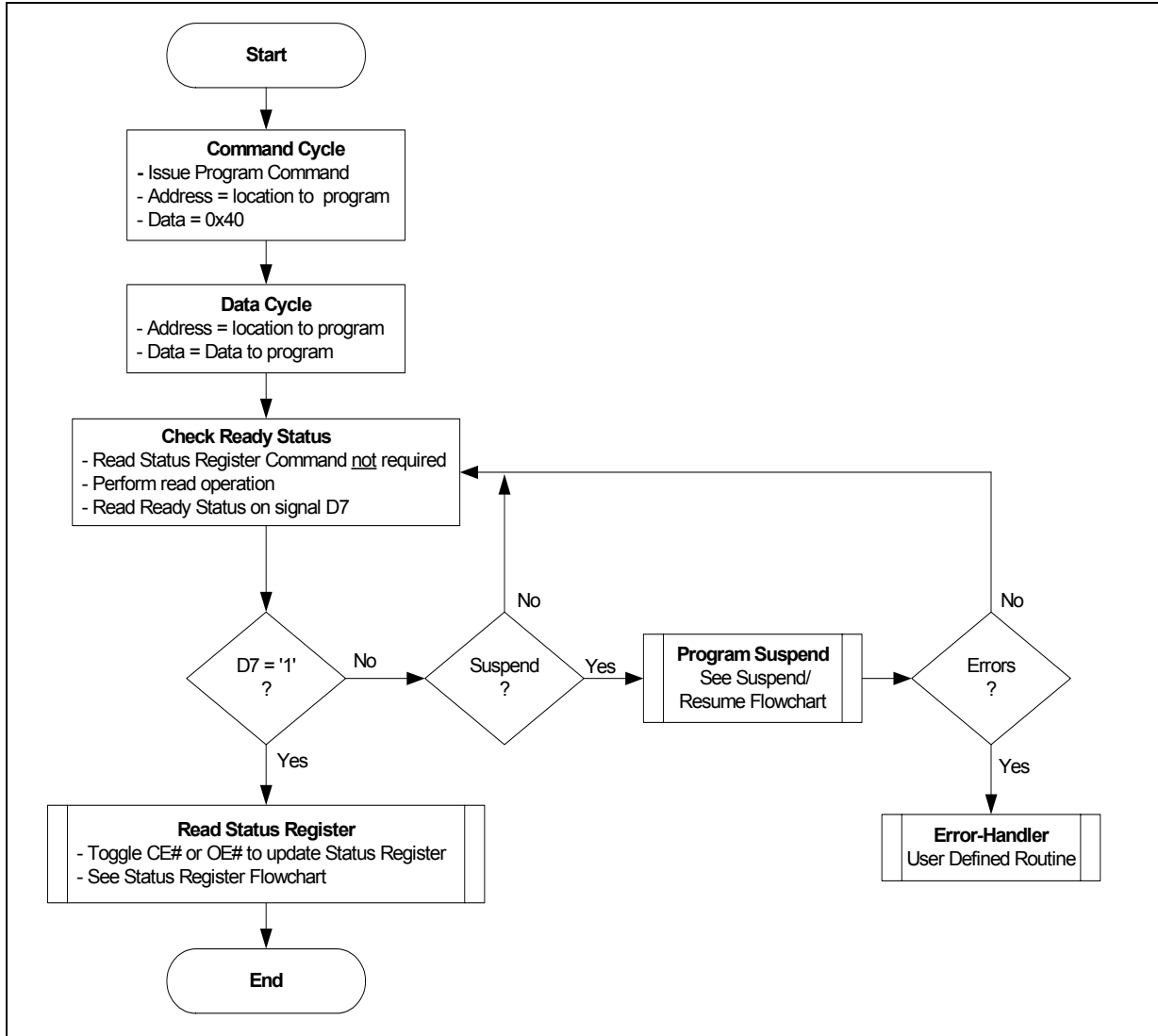

Figure 36: Program Suspend/Resume Flowchart

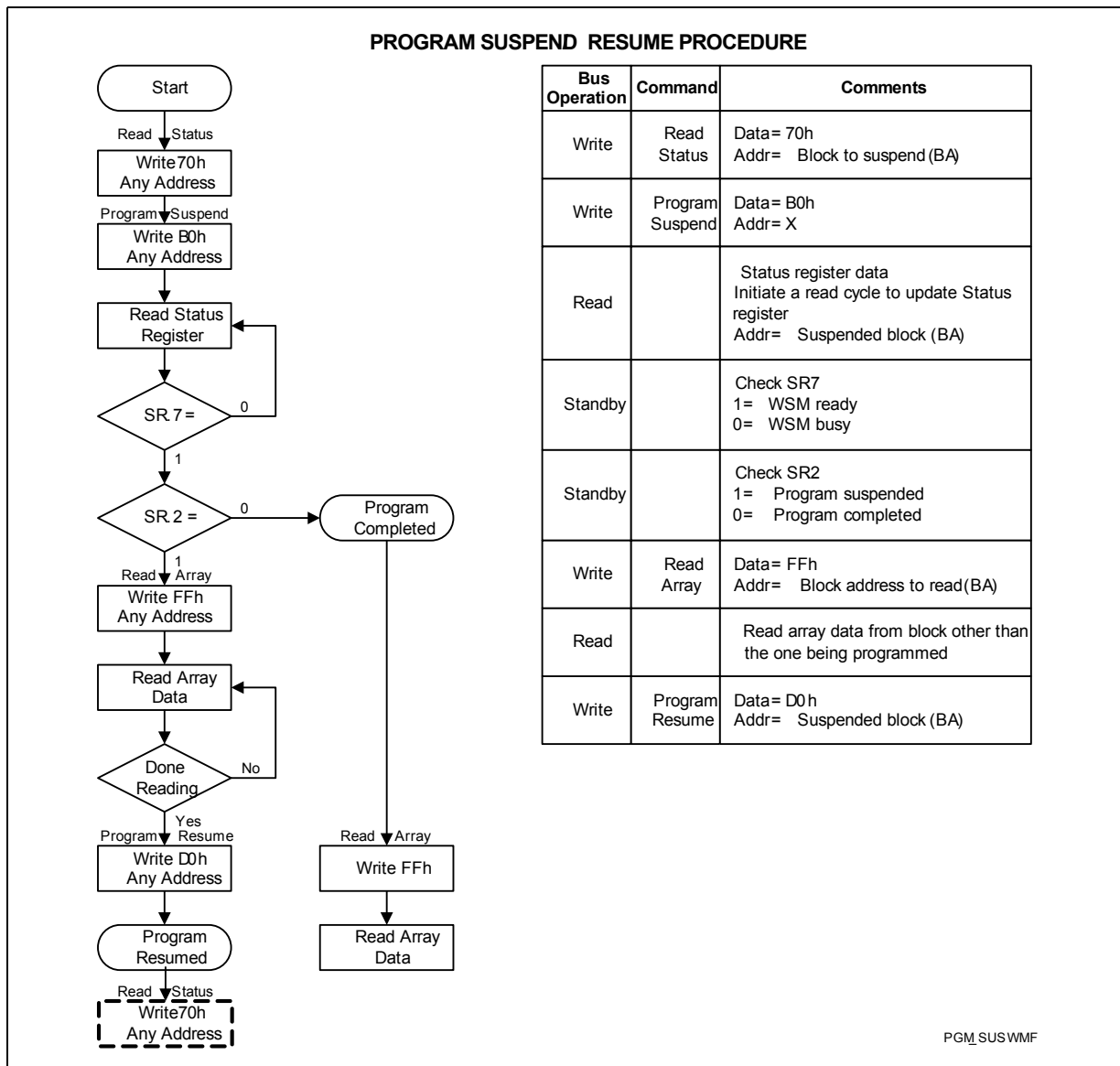
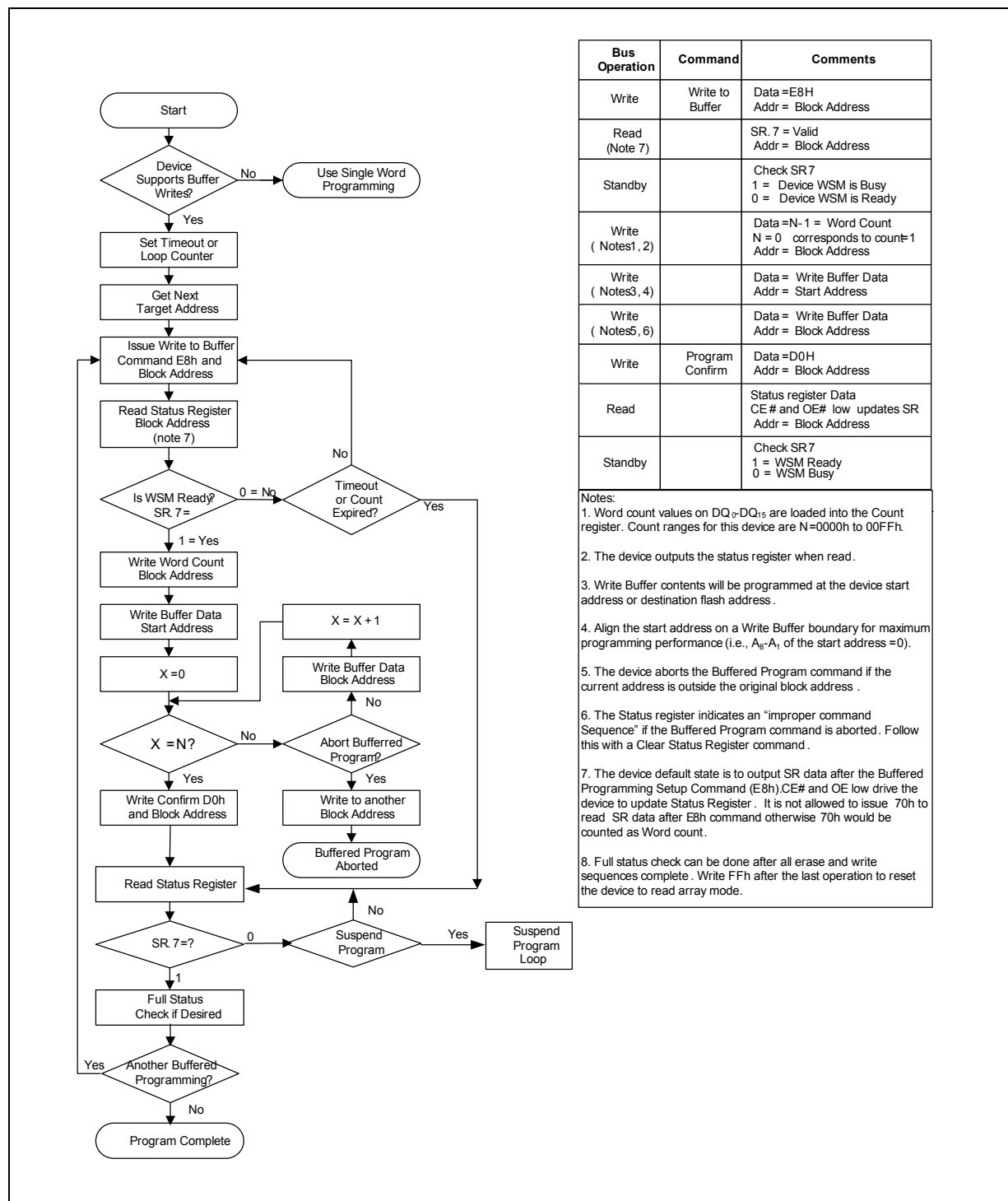

Figure 37: Buffer Program Flowchart



Bus Operation	Command	Comments
Write	Write to Buffer	Data =E8H Addr = Block Address
Read (Note 7)		SR. 7 = Valid Addr = Block Address
Standby		Check SR7 1 = Device WSM is Busy 0 = Device WSM is Ready
Write (Notes 1, 2)		Data =N- 1 = Word Count N = 0 corresponds to count=1 Addr = Block Address
Write (Notes 3, 4)		Data = Write Buffer Data Addr = Start Address
Write (Notes 5, 6)		Data = Write Buffer Data Addr = Block Address
Write	Program Confirm	Data =D0H Addr = Block Address
Read		Status register Data CE # and OE# low updates SR Addr = Block Address
Standby		Check SR7 1 = WSM Ready 0 = WSM Busy

Notes:

- Word count values on DQ₇-DQ₁₅ are loaded into the Count register. Count ranges for this device are N=0000h to 00FFh.
- The device outputs the status register when read.
- Write Buffer contents will be programmed at the device start address or destination flash address.
- Align the start address on a Write Buffer boundary for maximum programming performance (i.e., A₀-A₁ of the start address = 0).
- The device aborts the Buffered Program command if the current address is outside the original block address.
- The Status register indicates an "improper command Sequence" if the Buffered Program command is aborted. Follow this with a Clear Status Register command.
- The device default state is to output SR data after the Buffered Programming Setup Command (E8h). CE# and OE low drive the device to update Status Register. It is not allowed to issue 70h to read SR data after E8h command otherwise 70h would be counted as Word count.
- Full status check can be done after all erase and write sequences complete. Write FFh after the last operation to reset the device to read array mode.

Figure 38: BEFP Flowchart

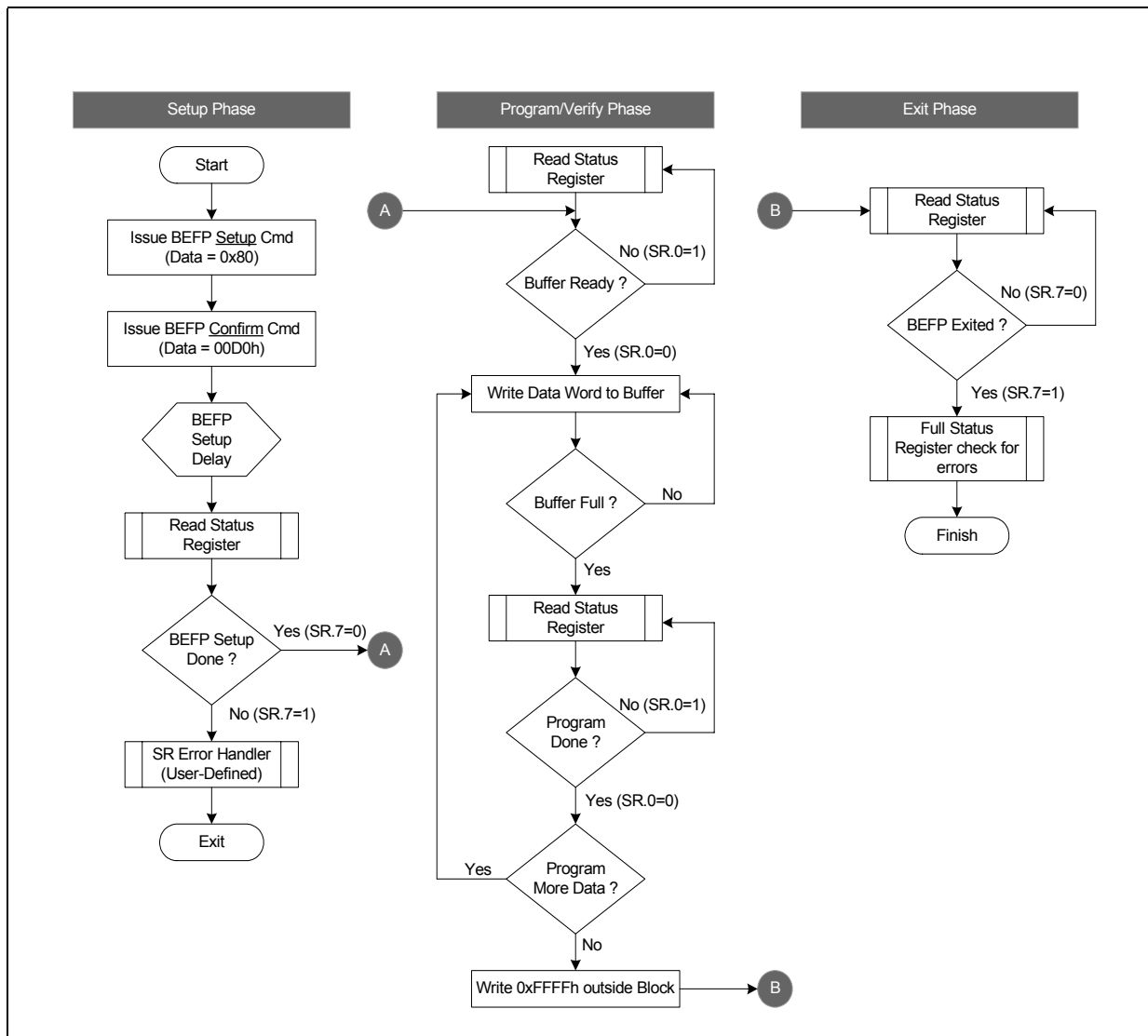

Figure 39: Block Erase Flowchart

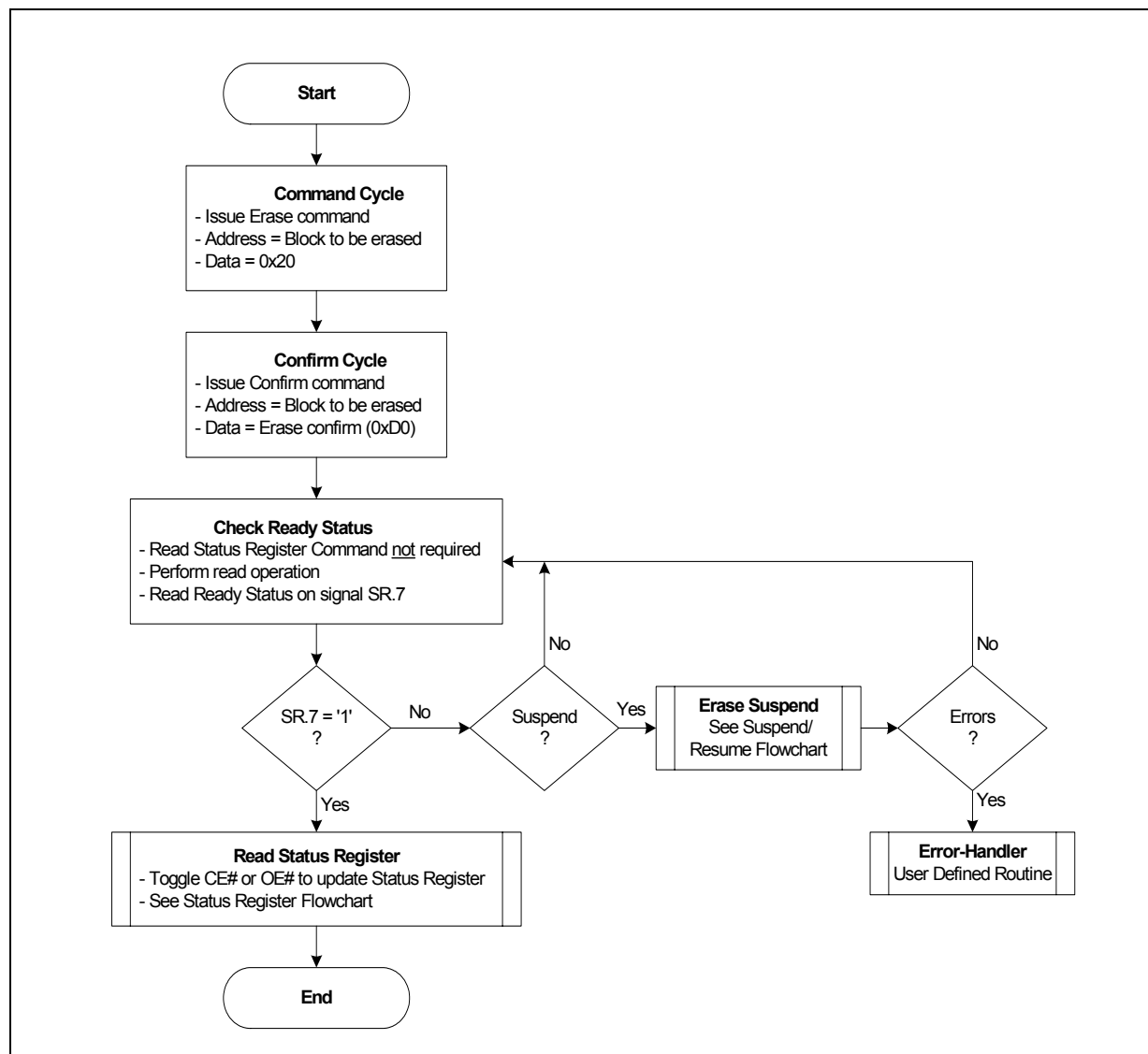

Figure 40: Erase Suspend/Resume Flowchart

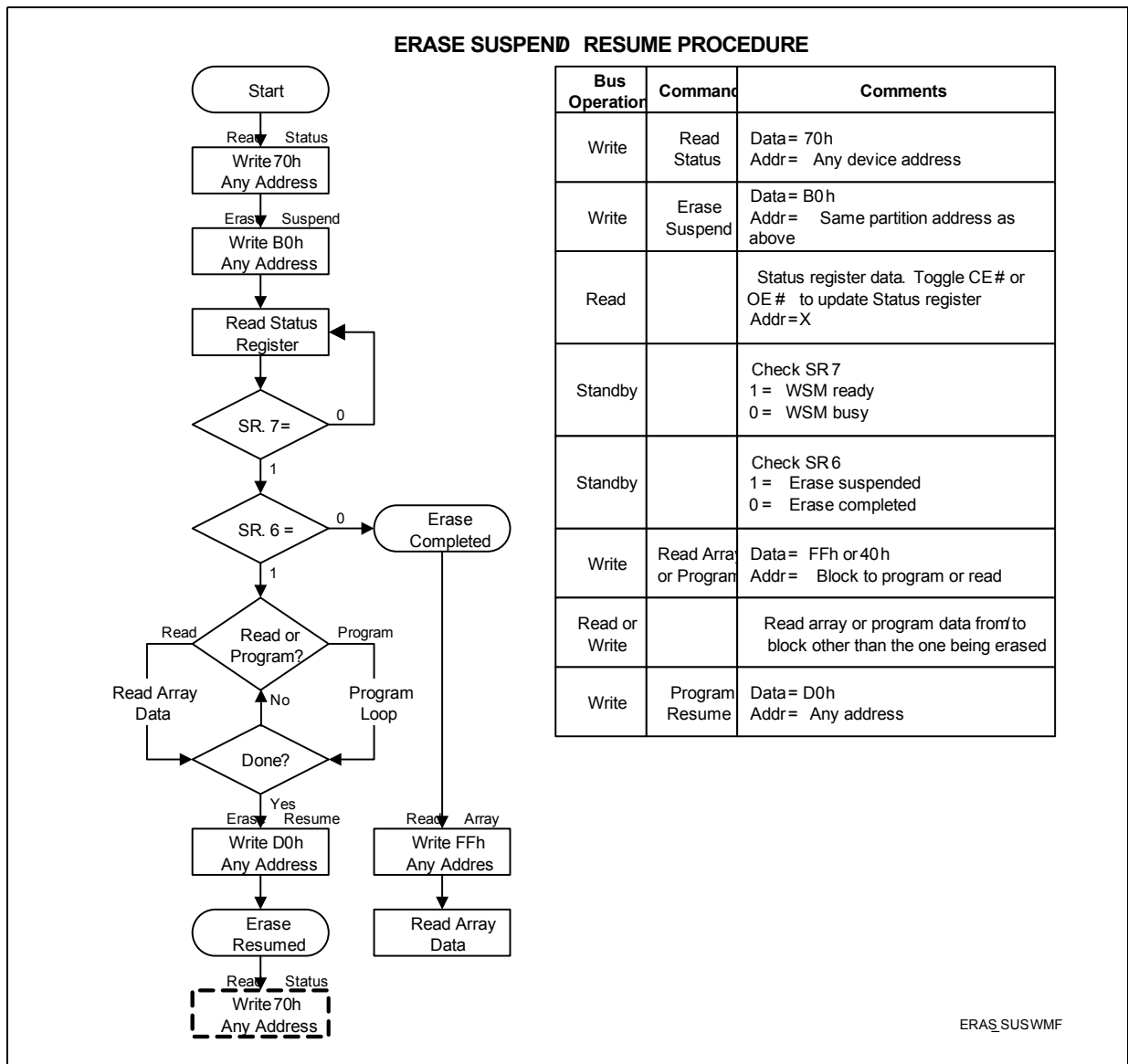

Figure 41: Block Lock Operations Flowchart

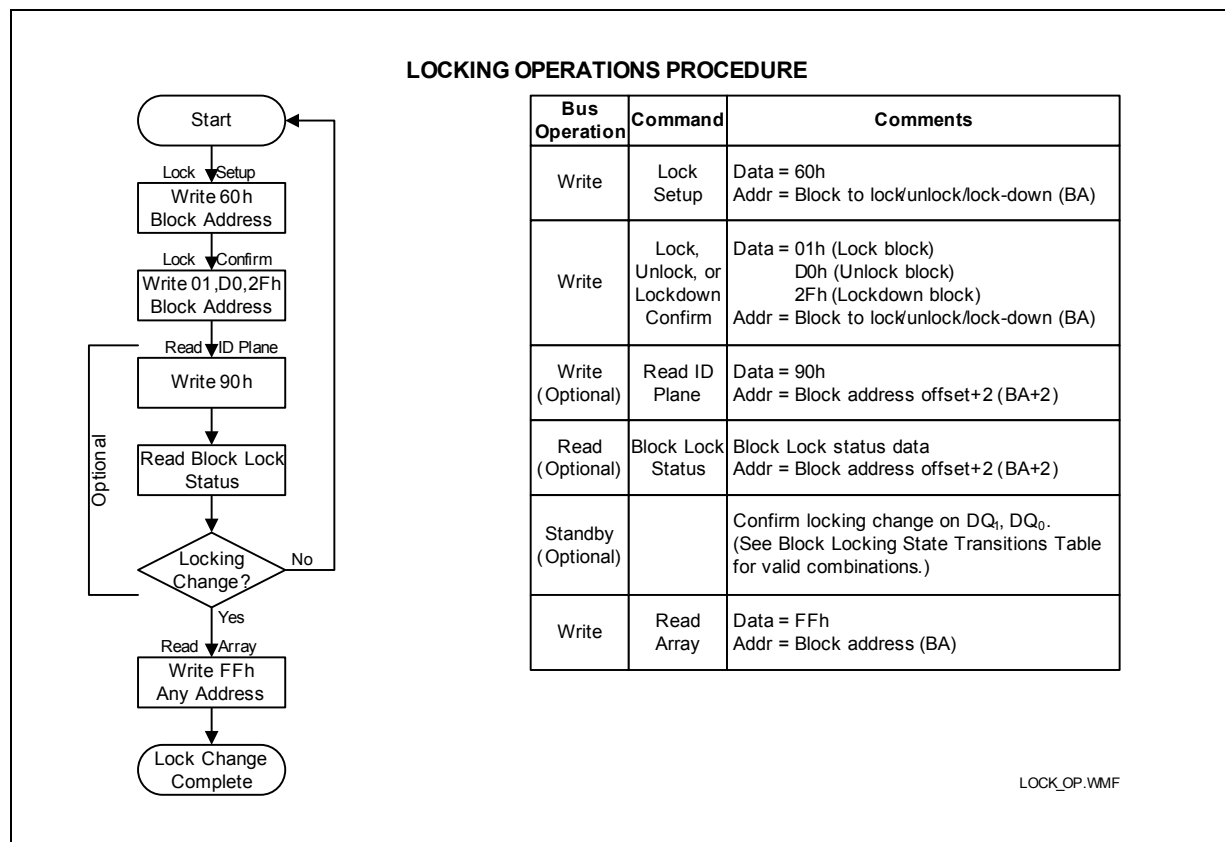

Figure 42: Protection Register Programming Flowchart

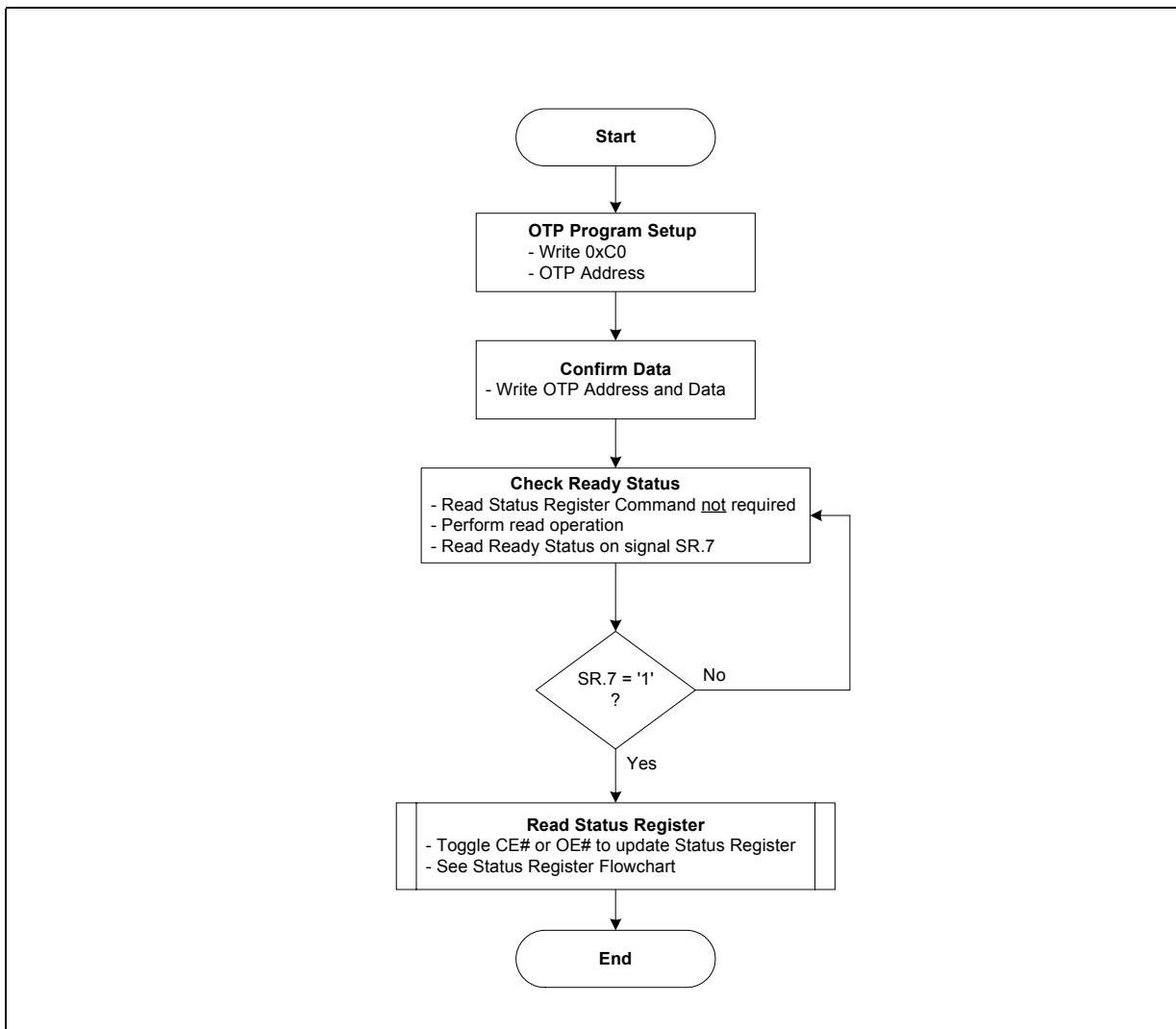
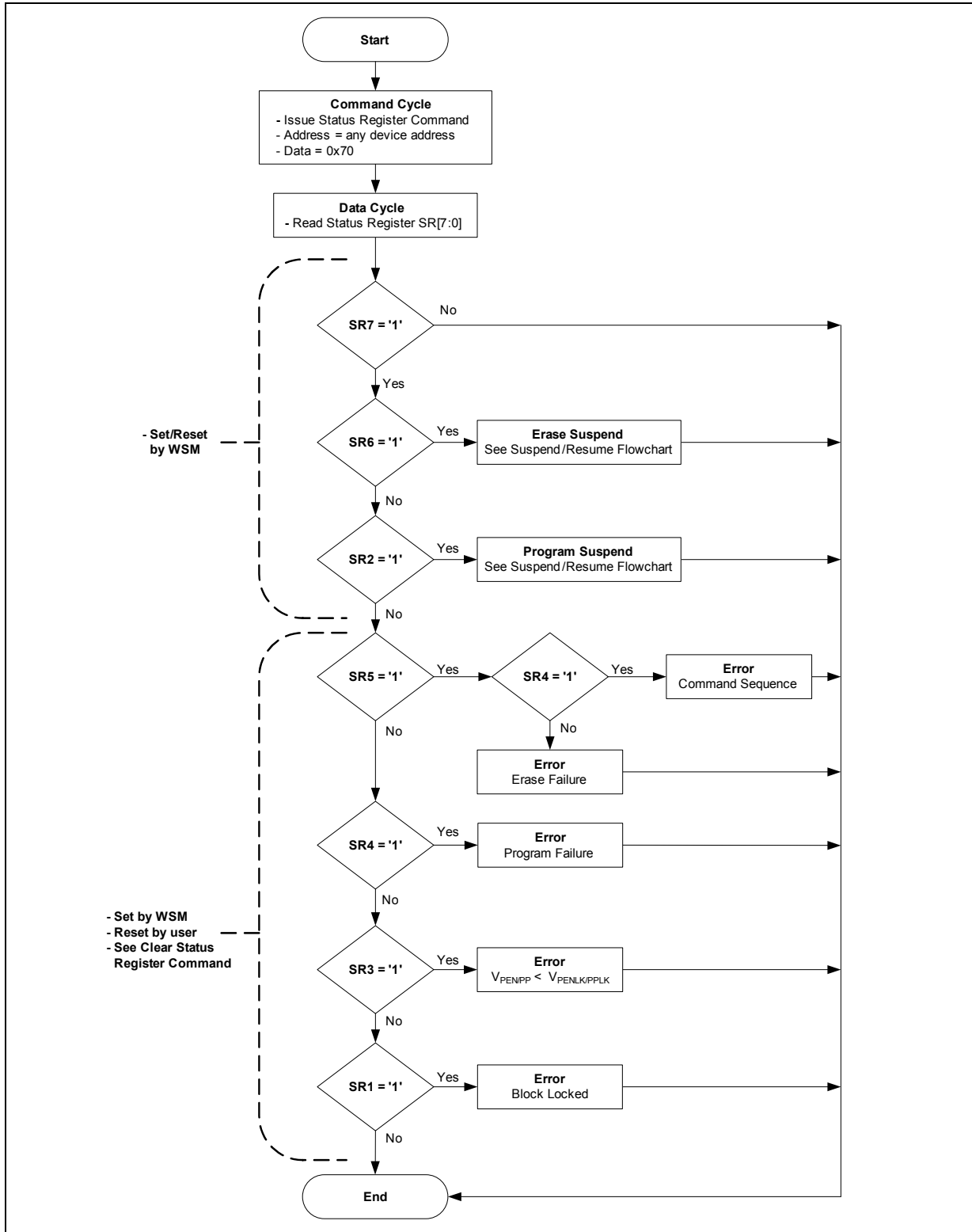

Figure 43: Status Register Flowchart



A.3 Write State Machine

The Next State Table shows the command state transitions (Next State Table) based on incoming commands. Only one partition can be actively programming or erasing at a time. Each partition stays in its last read state (Read Array, Read Device ID, Read CFI or Read Status Register) until a new command changes it. The next WSM state does not depend on the partition's output state.

Note: IS refers to Illegal State in the Next State Tables

Table 45: Next State Table for P30-65nm (Sheet 1 of 3)

Current Chip State		Command Input and Resulting Chip Next State ⁽¹⁾																			
		Array Read (3)	Word Pgm Setup (4,9)	BP Setup (8)	EFI Command Setup	Erase Setup (4,9)	BEFP Setup (6)	Confirm (7)	Pgm/Ers Suspend	Read Status	Clear SR (5)	Read ID/Query	Lock/RCR/ECR Setup	Blank Check	OTP Setup	Lock Blk Confirm (7)	Lock-down Blk Confirm (7)	Write ECR/RCR Confirm (7)	Block Address Change	Other Commands (2)	WSM Operation Completes
		(FFh)	(40h)	(E8h)	(EBh)	(20h)	(80h)	(D0h)	(B0)	(70h)	(50h)	(90h, 98h)	(60h)	(BCh)	(C0h)	(01h)	(2Fh)	(03h, 04h)		other	
Ready		Ready	Program Setup	BP Setup	EFI Setup	Erase Setup	BEFP Setup	Ready					Lock/RCR/ECR Setup	BC Setup	OTP Setup	Ready			N/A	Ready	N/A
Lock/RCR/ECR Setup		Ready (Lock Error [Botch])						Ready (Unlock Block)	Ready (Lock Error [Botch])						Ready (Lock Error [Botch])	Ready (Lock Block)	Ready (Lock down Block)	Ready (Set CR)	N/A	Ready (Lock Error [Botch])	N/A
OTP	Setup	OTP Busy																	N/A	OTP Busy	N/A
	Busy	OTP Busy	IS in OTP Busy	OTP Busy	IS in OTP Busy			OTP Busy					Illegal State in OTP Busy			OTP Busy			N/A	OTP Busy	Ready
	IS in OTP Busy	OTP Busy																	N/A	OTP Busy	N/A
Word Program	Setup	Word Program Busy																	N/A	Pgm Busy	N/A
	Busy	Pgm Busy	IS in Pgm Busy	Pgm Busy	IS in Pgm Busy		Pgm Busy	Pgm Susp	Word Pgm Busy		IS in Word Pgm Busy			Word Pgm Busy			N/A	Pgm Busy	Ready		
	IS in Pgm Busy	Word Pgm Busy																	N/A	Pgm Busy	N/A
	Suspend	Pgm Susp	IS in Pgm Susp	Pgm Suspend	IS in Pgm Susp		Pgm Busy	Pgm Susp	Pgm Susp (Er bits clear)	Word Pgm Susp	Illegal State in Pgm Suspend			Word Program Suspend			N/A	Word Pgm Susp	N/A		
IS in Pgm Suspend	Word Program Suspend																	N/A	Word Pgm Susp	N/A	
EFI	EFI Setup	Sub-function Setup																	N/A		N/A
	Sub-function Setup	Sub-op-code Load 1																	N/A		N/A
	Sub-op-code Load 1	Sub-function Load 2 if word count > 0, else Sub-function confirm																	N/A		N/A
	Sub-function Load 2	Sub-function Confirm if data load in program buffer is complete, ELSE Sub-function Load 2																	N/A		N/A
	Sub-function Confirm	Ready (Error [Botch])						S-fn Busy	Ready (Error [Botch])										N/A		N/A
	Sub-function Busy	S-fn Busy	IS in S-fn Busy	S-fn Busy	Illegal State in S-fn Busy		S-fn Busy	S-fn Susp	S-fn Busy		IS in S-fn Busy			S-fn Busy			S-fn Busy		Ready		
	IS in Sub-function Busy	Sub-function Busy																	N/A		N/A
	Sub-function Susp	S-fn Susp	IS in S-fn Susp	Sub-function	Illegal State in S-fn Busy		S-fn Busy	S-fn Susp	S-fn Susp (Er bits clear)	S-fn Susp	IS in S-fn Susp			S-fn Suspend			N/A	S-fn Susp	N/A		
	IS in S-fn Susp	Sub-function Suspend																	N/A		N/A

Table 45: Next State Table for P30-65nm (Sheet 2 of 3)

Current Chip State		Command Input and Resulting Chip Next State ⁽¹⁾																			
		Array Read (3)	Word Pgm Setup (4,9)	BP Setup (8)	EFI Command Setup	Erase Setup (4,9)	BEFP Setup (6)	Confirm (7)	Pgm/Ers Suspend	Read Status	Clear SR (5)	Read ID/Query	Lock/RCR/ECR Setup	Blank Check	OTP Setup	Lock Blk Confirm (7)	Lock-down Blk Confirm (7)	Write ECR/RCR Confirm (7)	Block Address Change	Other Commands (2)	WSM Operation Completes
		(Fh)	(40h)	(E8h)	(EBh)	(20h)	(80h)	(D0h)	(B0)	(70h)	(50h)	(90h, 98h)	(60h)	(BCh)	(C0h)	(01h)	(2Fh)	(03h, 04h)		other	
Buffer Pgm (BP)	Setup	BP Load 1																			
	BP Load 1 ⁽⁸⁾	BP Load 2 if word count >0, else BP confirm																			
	BP Load 2 ⁽⁸⁾	BP Confirm if data load in program buffer is complete, ELSE BP load 2																	Ready (Error [Botch])	BP Confirm if data load in program buffer is complete, else BP load 2	N/A
	BP Confirm	Ready (Error [Botch])							BP Busy	Ready (Error [Botch])											
	BP Busy	BP Busy	IS in BP Busy	BP Busy	Illegal State in BP Busy	BP Busy	BP Susp	BP Busy			IS in BP Busy		BP Busy		BP Busy						
	IS in BP Busy	BP Busy																			
Erase	BP Susp	BP Susp	IS in BP Susp	BP Suspend	Illegal State in BP Susp	BP Busy	BP Suspend	BP Susp (Er bits clear)	BP Susp	IS in BP Susp		BP Suspend		N/A	BP Susp						
	IS in BP Susp	BP Suspend																			
	Setup	Ready (Error [Botch])							Erase Busy	Ready (Error [Botch])							N/A	Ready (Err Botch0)	N/A		
	Busy	Erase Busy	IS in Erase Busy	Erase Busy	IS in Erase Busy	Erase Busy	Erase Susp	Erase Busy			IS in Erase Busy		Erase Busy		N/A	Ers Busy					
	IS in Erase Busy	Erase Busy																			
	Suspend	Erase Susp	Word Pgm Setup in Erase Susp	BP Setup in Erase Susp	EFI Setup in Erase Susp	IS in Erase Suspend	Erase Busy	Erase Suspend	Erase Susp (Er bits clear)	Erase Susp	Lock/RCR/ECR Setup in Erase Susp	Erase Susp	IS in Erase Susp	Erase Suspend		N/A	Erase Susp				
IS in Erase Susp	Erase Suspend																				
Word Pgm in Erase Suspend	Setup	Word Pgm busy in Erase Suspend																			
	Busy	Word Pgm busy in Erase Susp	IS in Pgm busy in Ers Susp	Word Pgm busy in Erase Susp	IS in Word Pgm busy in Ers Susp	Word Pgm busy in Erase Susp	Word Pgm Susp in Ers Susp	Word Pgm busy in Erase Susp	IS in Word Pgm busy in Ers Susp	Word Pgm busy in Erase Susp	IS in Word Pgm busy in Ers Susp	Word Pgm busy in Erase Susp	N/A	Word Pgm busy in Erase Susp		IS in Erase Susp					
	Illegal state (IS) in Pgm busy in Erase Suspend	Word Pgm busy in Erase Suspend																			
	Suspend	Word Pgm susp in Ers susp	IS in pgm susp in Ers susp	Word Pgm susp in Erase susp	IS in pgm susp in Ers Susp	Word Pgm busy in Erase Susp	Word Pgm susp in Ers susp	Word Pgm susp in Ers susp	Word Pgm Susp in Ers Susp (Er bits clear)	Word Pgm susp in Ers susp	IS in Word Pgm susp in Ers Susp	Word Pgm susp in Erase susp	N/A	Word Pgm susp in Erase susp		IS in Erase Susp					
Illegal State in Word Program Suspend in Erase Suspend	Word Pgm busy in Erase Suspend																				
BP in Erase Suspend	Setup	BP Load 1 in Erase Suspend																			
	BP Load 1 ⁽⁸⁾	BP Load 2 in Erase Suspend if word count >0, else BP confirm																			
	BP Load 2 ⁽⁸⁾	BP Confirming Erase Suspend if data load in program buffer is complete, ELSE BP load 2 in Erase Suspend																	Ers Susp (Error [Botch])	BP Confirm in Erase Suspend when count=0, ELSE BP load 2	N/A
	BP Confirm	Erase Suspend (Error [BotchBP])							BP Busy in Erase Susp	Erase Susp (Error [BotchBP])											
	BP Busy	BP Busy in Erase Susp	IS in BP Busy in Erase Susp	BP Busy in Erase Susp	Illegal State in BP Busy in Erase Susp	BP Busy in Erase Susp	BP Susp in Erase Susp	BP Busy in Erase Susp			IS in BP Busy in Erase Suspend		BP Busy in Erase Susp		N/A	BP Busy in Erase Susp					
	IS in BP Busy	BP Busy in Erase Suspend																			
BP Susp	BP Susp in Erase Susp	IS in BP Susp in Erase Susp	BP Suspend in Erase Suspend	Illegal State in BP Busy in Erase Susp	BP Busy in Erase Susp	BP Susp in Erase Susp	BP Susp in Erase Susp	BP Susp in Erase Susp (Er bits clear)	BP Susp in Erase Susp	IS in BP Busy in Erase Suspend	BP Susp in Erase Susp		N/A	BP Susp in Erase Susp							
IS in BP Suspend	BP Suspend in Erase Suspend																				

Table 45: Next State Table for P30-65nm (Sheet 3 of 3)

Current Chip State		Command Input and Resulting Chip Next State ⁽¹⁾																WSM Operation Completes				
		Array Read (3)	Word Pgm Setup (4,9)	BP Setup (8)	EFI Command Setup	Erase Setup (4,9)	BEFP Setup (6)	Confirm (7)	Pgm/Ers Suspend	Read Status	Clear SR (5)	Read ID/Query	Lock/RCR/ECR Setup	Blank Check	OTP Setup	Lock Blk Confirm (7)	Lock-down Blk Confirm (7)		Write ECR/RCR Confirm (7)	Block Address Change	Other Commands (2)	
		(FFh)	(40h)	(E8h)	(EBh)	(20h)	(80h)	(D0h)	(B0)	(70h)	(50h)	(90h, 98h)	(60h)	(BCh)	(C0h)	(01h)	(2Fh)	(03h, 04h)		other		
EFI in Erase Suspend	EFI Setup	Sub-function Setup in Erase Suspend																			N/A	
	Sub-function Setup	Sub-op-code Load 1 in Erase Suspend																				
	Sub-op-code Load 1	Sub-function Load 2 in Erase Suspend if word count >0, else Sub-function confirm in Erase Suspend																				
	Sub-function Load 2	Sub-function Confirm in Erase Suspend if data load in program buffer is complete, ELSE Sub-function Load 2																Ers Susp (Error [Botch])	Sub-function Confirm if data load in program buffer is complete, ELSE Sub-function Load 2			
	Sub-function Confirm	Erase Suspend (Error [Botch])				S-fn Busy in Ers Susp	Erase Suspend (Error [Botch])															
	Sub-function Busy	S-fn Busy in Ers Susp	IS in S-fn Busy in Ers Susp	S-fn Busy in Ers Suspend	Illegal State in S-fn Busy in Ers Susp	S-fn Busy in Ers Susp	S-fn Susp in Ers Susp	S-fn Busy in Ers Susp	S-fn Busy in Ers Susp	IS in S-fn Busy in Ers Susp	S-fn Busy in Ers Susp	S-fn Busy in Ers Susp	S-fn Busy in Ers Susp	S-fn Busy in Ers Susp	S-fn Busy in Ers Susp	S-fn Busy in Ers Susp	S-fn Busy in Ers Susp	S-fn Busy in Ers Susp	N/A	S-fn Busy in Ers Susp		Erase Susp
	IS in Sub-function Busy	Sub-function Busy in Ers Susp																				IS in Ers Susp
Sub-function Suspend	S-fn Susp in Ers Susp	IS in S-fn Susp in Ers Susp	S-fn Suspend in Ers Susp	Illegal State in S-fn Busy in Ers Susp	S-fn Busy in Ers Susp	S-fn Suspend in Ers Susp	S-fn Susp in Ers Susp (Er bits clear)	S-fn Susp in Ers Susp	IS in S-fn Susp in Ers Susp	S-fn Suspend in Ers Susp	S-fn Suspend in Ers Susp	S-fn Suspend in Ers Susp	S-fn Suspend in Ers Susp	S-fn Suspend in Ers Susp	S-fn Suspend in Ers Susp	S-fn Suspend in Ers Susp	S-fn Suspend in Ers Susp	N/A	S-fn Susp in Ers Susp	N/A		
IS in Phase-1 Susp	Sub-Function Suspend in Erase Suspend																					
Lock/RCR/ECR/Lock EFA Block Setup in Erase Suspend	Erase Suspend (Lock Error [Botch])				Ers Susp (Un-lock Block)	Ers Susp (Lock Error [Botch])				Ers Susp (Error [Botch])	Ers Susp Blk Lock	Ers Susp Blk Lk-Down	Ers Susp CR Set	N/A	Ers Susp (Error [Botch])			N/A				
Blank Check	Setup	Ready (Error [Botch])				BC Busy	Ready (Error [Botch])														Ready (Error [Botch])	N/A
	Blank Check Busy	BC Busy	IS in BC Busy	BC Busy	IS in BC Busy	Blank Check Busy				IS in BC Busy			BC Busy			N/A	BC Busy		Ready			
	IS in Blank Check Busy	BP Busy																				
BEFP	Setup	Ready (Error [Botch])				BEFP Load Data	Ready (Error [Botch])														N/A	
	BEFP Busy	BEFP Program and Verify Busy (if Block Address given matches address given on BEFP Setup command). Commands treated as data. (7)																Ready	BEFP Busy		Ready	

Table 46: Output Next State Table for P30-65nm

		Command Input to Chip and Resulting Output MUX Next State ⁽¹⁾																		
Current Chip State	Array Read (3)	Word Pgm Setup (4,9)	BP Setup (8)	EFI Command Setup	Erase Setup (4,9)	BEFP Setup (6)	Confirm (7)	Pgm/Ers Suspend	Read Status	Clear SR (5)	Read ID/Query	Lock/RCR/ECR Setup	Blank Check	OTP Setup	Lock Bik Confirm (7)	Lock-down Bik Confirm (7)	Write ECR/RCR Confirm (7)	Block Address Change	Other Commands (2)	WSM Operation Completes
	(FFh)	(40h)	(E8h)	(EBh)	(20h)	(80h)	(D0h)	(B0)	(70h)	(50h)	(90h, 98h)	(60h)	(BCh)	(C0h)	(01h)	(2Fh)	(03h, 04h)		other	
BEFP Setup, BEFP Pgm & Verify Busy, Erase Setup, OTP Setup, BP Setup, Load 1, Load 2 BP Setup, Load1, Load 2 - in Erase Susp. BP Confirm EFI Sub-function Confirm WordPgmSetup, Word Pgm Setup in Erase Susp, BP Confirm in Erase Suspend, EFI S-fn Confirm in Ers Susp, Blank Check Setup, Blank Check Busy	Status Read																			
Lock/RCR/ECR Setup, Lock/RCR/ECR Setup in Erase Susp	Status Read																Array Read			
EFI S-fn Setup, Ld 1, Ld 2 EFI S-fn Setup, Ld1, Ld 2 - in Erase Susp.	Output MUX will not change																			
BP Busy BP Busy in Erase Suspend EFI Sub-function Busy EFI Sub-fn Busy in Ers Susp Word Program Busy, Word Pgm Busy in Erase Suspend, OTP Busy Erase Busy	Status Read	Status Read	Status Read	Status Read	Status Read	Output MUX Does not Change	Status Read	Array Read	Status Read	Status Read	Status Read	Status Read	Output MUX does not Change							
Ready, Word Pgm Suspend, BP Suspend, Phase-1 BP Suspend, Erase Suspend, BP Suspend in Erase Suspend Phase-1 BP Susp in Ers Susp	Array Read																			

Notes:

- IS refers to *Illegal State* in the Next State Table.
- "Illegal commands" include commands outside of the allowed command set.
- The device defaults to "Read Array" on powerup.
- If a "Read Array" is attempted when the device is busy, the result will be "garbage" data (we should not tell the user that it will actually be Status Register data). The key point is that the output mux will be pointing to the "array", but garbage data will be output. "Read ID" and "Read Query" commands do the exact same thing in the device. The ID and Query data are located at different locations in the address map.
- The Clear Status command only clears the error bits in the status register if the device is not in the following modes: 1. WSM running (Pgm Busy, Erase Busy, Pgm Busy In Erase Suspend, OTP Busy, BEFP modes) 2. Suspend states (Erase Suspend, Pgm Suspend, Pgm Suspend In Erase Suspend).
- BEFP writes are only allowed when the status register bit #0 = 0 or else the data is ignored.
- Confirm commands (Lock Block, Unlock Block, Lock-Down Block, Configuration Register and Blank Check) perform the operation and then move to the Ready State.
- Buffered programming will botch when a different block address (as compared to the address given on the first data write cycle) is written during the BP Load1 and BP Load2 states.
- All two cycle commands will be considered as a contiguous whole during device suspend states. Individual commands will not be parsed separately. (I.e. If an erase set-up command is issued followed by a D0h command, the D0h command will not resume the program operation. Issuing the erase set-up places the CUI in an "illegal state". A subsequent command will clear the "illegal state", but the command will be otherwise ignored.

Appendix B Conventions - Additional Information

B.1 Conventions

VCC:	Signal or voltage connection
V _{CC} :	Signal or voltage level
0x:	Hexadecimal number prefix
h:	Hexadecimal number suffix
0b:	Binary number prefix
SR.4:	Denotes an individual register bit.
A[15:0]:	Denotes a group of similarly named signals, such as address or data bus.
A5:	Denotes one element of a signal group membership, such as an individual address bit.
Bit:	Binary unit
Byte:	Eight bits
Word:	Two bytes, or sixteen bits
Kbit:	1024 bits
KByte:	1024 bytes
KWord:	1024 words
Mbit:	1,048,576 bits
MByte:	1,048,576 bytes
MWord:	1,048,576 words

B.2 Acronyms

BEFP:	Buffer Enhanced Factory Programming
CFI:	Common Flash Interface
MLC:	Multi-Level Cell
OTP:	One-Time Programmable
PLR:	Protection Lock Register
PR:	Protection Register
RCR:	Read Configuration Register
RFU:	Reserved for Future Use
SR:	Status Register
WSM:	Write State Machine
SRD	Status Register Data
CUI	Command User Interface
EFI	Extended Function Interface
PAD	Password Access Data

B.3 Nomenclature

Block :	A group of bits, bytes, or words within the flash memory array that erase simultaneously. The P30-65nm has two block sizes: 32 KByte and 128 KByte.
Main block :	An array block that is usually used to store code and/or data. Main blocks are larger than parameter blocks.
Parameter block :	An array block that may be used to store frequently changing data or small system parameters that traditionally would be stored in EEPROM.
Top parameter device :	A device with its parameter blocks located at the highest physical address of its memory map.
Bottom parameter device :	A device with its parameter blocks located at the lowest physical address of its memory map.

Appendix C Revision History

Revision Date	Revision	Description
Mar 2010	10	<p>Program performance update in front page, Section 29, "Program and Erase Specifications" and CFI.</p> <p>t_{DVWH} specification comments, Table 28, "AC Write Specifications" on page 59.</p> <p>Erase/program suspend latency specification update, Table 29, "Program and Erase Specifications" on page 63.</p> <p>Leaded TSOP part EOL.</p> <p>Burst latency update and 40MHz spec update, Table 16, "LC and Frequency Support" on page 42.</p> <p>Clarify the capacitance, Table 26, "Capacitance" on page 54.</p> <p>Ordering Information update.</p>
Aug 2009	09	<p>QUAD+ ball height correction to 0.2mm in Figure 4.</p> <p>Update the Block lock Operations, Program Suspend/Resume, Erase Suspend/Resume flowcharts in Figure 41, Figure 36, Figure 40, backward compatible with 130nm.</p> <p>Align the sequence error description in Table 14.</p> <p>Add TSOP 40MHz Burst Spec in Table 27, "AC Read Specifications".</p> <p>Add note 7 in buffer program flowchart Figure 37.</p> <p>Update V_{IL} undershoot and overshoot of Note 2 in Table 24.</p> <p>Update CFI 0x2A data in Table 37, "Device Geometry Definition".</p>
Apr 2009	08	<p>Add 512 Mbit (256/256) memory map in Figure 1, "P30-65nm Memory Map" on page 7</p> <p>Update QUAD+ signal description by changing A25 into RFU in Figure 8, "QUAD+ SCSP Ballout and Signals" on page 15.</p> <p>Correct RCR.4, RCR.5, RCR.7 and RCR.9 definitions in Table 15, "Read Configuration Register Description" on page 39.</p> <p>Correct A_0 to A_1 signal naming and remove invalid x8 information in Table 33, "Example of CFI Structure Output of x16 Devices" on page 67.</p>
Jan 2008	07	<p>Update QUAD+ package ballout H8 from OE# to F2-OE#. See Figure 8, "QUAD+ SCSP Ballout and Signals" on page 15.</p> <p>Update QUAD+ Signal Description A[$MAX:1$] to A[$MAX:0$] and its Name and Function. See Figure 6, "QUAD+ SCSP Signal Descriptions" on page 17.</p> <p>Update Virtual Chip Enable Description from Address 25 to the maximum address bit. See Section 1.3, "Virtual Chip Enable Description" on page 6.</p> <p>Update TSOP Pinout P13 from VCC to RFU. See Section 6, "56-Lead TSOP Pinout (256-Mbit)" on page 13.</p> <p>Complete Section 9.2, "Blank Check" on page 33.</p> <p>Minor wording modifications.</p>
Dec 2008	06	<p>Correct page buffer address bit to Four on Section 7.1, "Asynchronous Page-Mode Read".</p> <p>Correct VHH to V_{PPH} on Table 23, "DC Current Characteristics" on page 51 note 7.</p>
Nov 2008	05	<p>Remove 128M related contents;</p> <p>Return to StrataFlash trademark;</p> <p>Update the buffer program for cross 512-Word boundary;</p> <p>Correct A24 to A25 for virtual CE description in section 1.3;</p> <p>Remove Numonyx Confidential.</p>
Nov 2008	04	<p>Update Buffer program flowchart same as 130nm;</p> <p>Minor wording modifications.</p>
Sep 2008	03	<p>Update new trademark Axcell;</p> <p>Remove 64M related contents.</p>
July 2008	02	<p>Add W28 AC specification;</p> <p>Fix Buffered Program Command error in figure 38;</p> <p>Update block locking state diagram;</p> <p>Update Address range in Memory Map figure;</p> <p>Change LSB Address in ballout and pinout description from A0 back to A1 to match P30 130nm.</p>

Revision Date	Revision	Description
May 2008	01	Initial Release