

MGA-13116

High Gain, High Linearity, Very Low Noise Amplifier



Data Sheet

Description

Avago Technologies' MGA-13116 is a two stage, easy-to-use GaAs MMIC Low Noise Amplifier (LNA). The LNA has low noise with good input return loss and high linearity achieved through the use of Avago Technologies' proprietary 0.25 μm GaAs Enhancement-mode pHEMT process. Minimum matching needed for input, output and the inter-stage between the two LNA.

It is designed for optimum use between 400 MHz to 1.5 GHz. For optimum performance at higher frequency from 1.5 GHz to 2.5 GHz, the MGA-13216 is recommended. Both MGA-13116 & MGA-13216 share the same package and pinout configuration.

Pin Configuration and Package Marking

4.0 x 4.0 x 0.85 mm³ 16-lead QFN

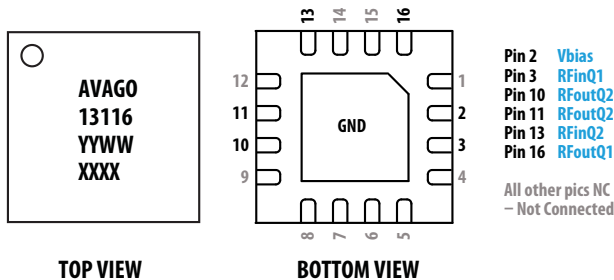

Note:

Package marking provides orientation and identification

"13116" = Device Part Number

"YYWW" = Work Week and Year of Manufacture

"XXXX" = Lot Number



Attention: Observe precautions for handling electrostatic sensitive devices.
ESD Machine Model = 90 V
ESD Human Body Model = 300 V
Refer to Avago Application Note A004R:
Electrostatic Discharge, Damage and Control.

Features

- Optimum frequency of operation 400 MHz – 1.5 GHz
- Very low noise figure
- High gain
- High linearity performance
- Excellent isolation
- GaAs E-pHEMT Technology^[1]
- Low cost small package size: 4.0 x 4.0 x 0.85 mm³

Specifications

900 MHz; Q1: 5 V, 55 mA (typ) Q2: 5 V, 112 mA (typ)

- 0.51 dB Noise Figure
- 38 dB Gain
- 52 dB RFoutQ1 to RFinQ2 Isolation
- 41.4 dBm Output IP3
- 23.3 dBm Output Power at 1dB gain compression

Applications

- Low noise amplifier for cellular infrastructure including GSM, CDMA, and W-CDMA.
- Other very low noise applications.

Simplified Schematic

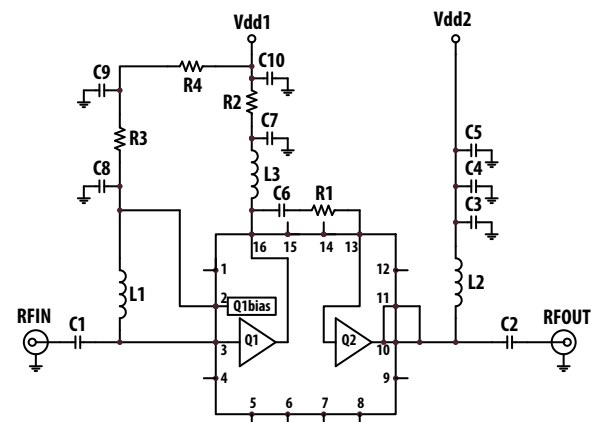

Notes: Enhancement mode technology employs positive gate bias, thereby eliminating the need of negative gate voltage associated with conventional depletion mode devices.

MGA-13116 Absolute Maximum Rating ^[1] TA = 25° C

Symbol	Parameter	Units	Absolute Maximum
Vdd1	Device Voltage	V	5.5
Vdd2	Device Voltage	V	5.5
Idd1	Q1 Drain Current	mA	90
Pd	Power Dissipation ⁽²⁾	W	1.02
P _{in,max}	CW RF Input Power	dBm	20
T _{j,max}	Junction Temperature	°C	150
T _{stg}	Storage Temperature	°C	-65 to 150

Thermal Resistance ^[3]

(V_{dd1} = 5.0V, I_{dd1} = 55mA, V_{dd2} = 5.0V, I_{dd2} = 112mA) $\theta_{jc} = 41.9^{\circ}\text{C/W}$

Notes:

1. Operation of this device in excess of any of these limits may cause permanent damage.
2. Board temperature (T_c) is 25° C. For T_c > 100° C, derate the device power at 23.9 mW per °C rise in board temperature adjacent to package bottom.
3. Thermal resistance measured using Infrared Measurement Technique.

Electrical Specifications ^[1]

RF performance at V_{dd1} = 5 V, V_{dd2} = 5 V, 900 MHz, T_A = 25° C, measured on the demo board.

Symbol	Parameter and Test Condition	Units	Min.	Typ.	Max.
Idd1	Current at Q1	mA	42	55	69
Idd2	Current at Q2	mA	92	112	131
NF	Noise Figure	dB	–	0.51	0.85
Gain	Gain	dB	36.5	38	39.5
OIP3 ^[2]	Output Third Order Intercept Point	dBm	37.5	41.4	–
OP1dB	Output Power at 1 dB Gain Compression	dBm	22	23.3	–
IRL	Input Return Loss, 50 Ω source	dB	–	-19	–
ORL	Output Return Loss, 50 Ω load	dB	–	-12	–
S ₁₂	Reverse Isolation	dB	–	48	–
ISOL ₁₋₂	Isolation between Q1's Output pin & Q2's Input pin	dB	–	52	–

Notes:

1. Measurements obtained using demo board described in Figure 7 with component list in Table 1. Input and Output trace loss is not de-embedded from the measurement.
2. OIP3 test condition: f_{tone1} = 900 MHz, f_{tone2} = 901 MHz with input power of -29 dBm per tone.
3. Use proper bias, heatsink and derating to ensure maximum channel temperature is not exceeded. See absolute maximum ratings and application note for more details.

Product consistency Distribution Charts [1,2]

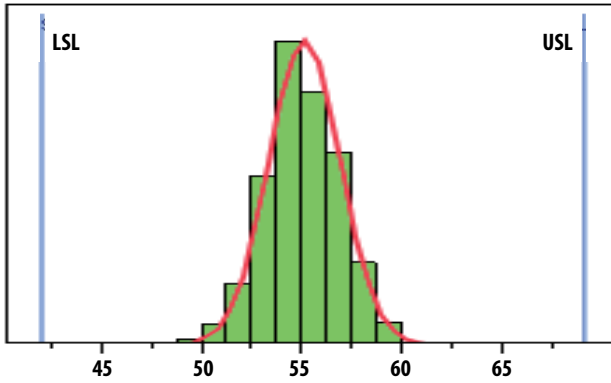

Figure 1. Idd1 @ 900 MHz, Vdd1 = 5 V, LSL = 42 mA, Nominal = 55 mA, USL = 69 mA

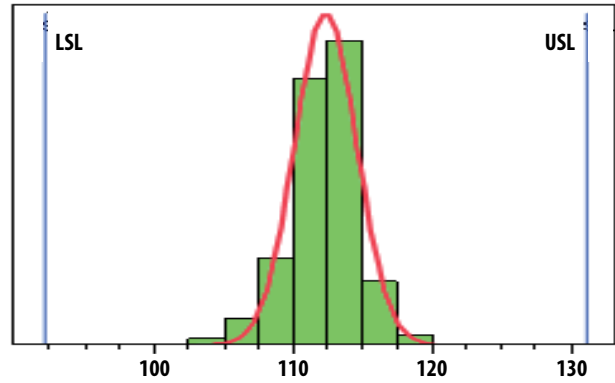

Figure 2. Idd2 @ 900 MHz, Vdd2 = 5 V, LSL = 92 mA, Nominal = 112 mA, USL = 131 mA

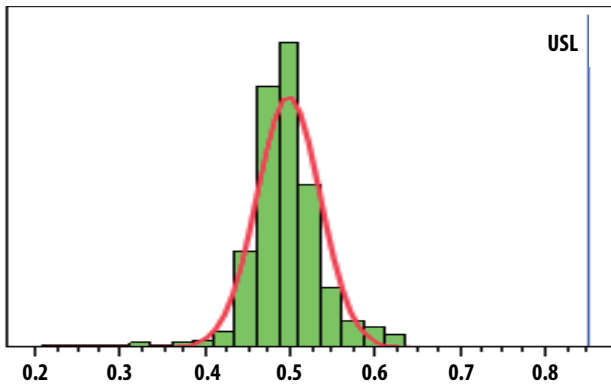

Figure 3. Noise Figure @ 900 MHz, Vdd1 = 5 V, Vdd2 = 5 V, Nominal = 0.51 dB, USL = 0.85 dB

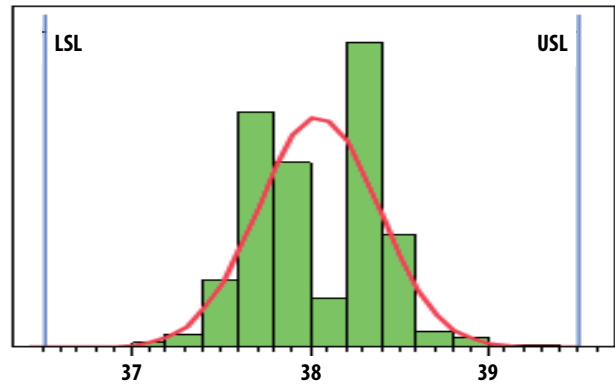

Figure 4. Gain @ 900 MHz, Vdd1 = 5 V, Vdd2 = 5 V, LSL = 36.5 dB, Nominal = 38 dB, USL = 39.5 dB

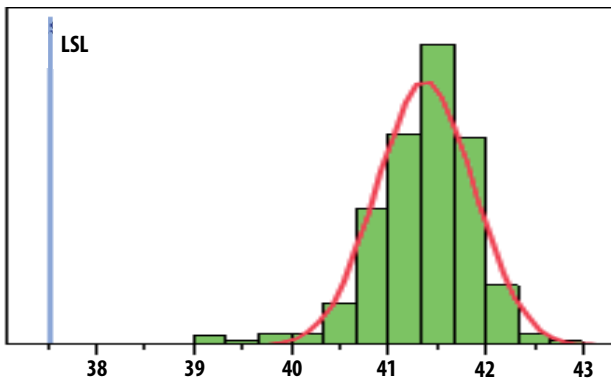

Figure 5. OIP3 @ 900 MHz, Vdd1 = 5 V, Vdd2 = 5 V, LSL = 37.5 dBm, Nominal = 41.4 dBm

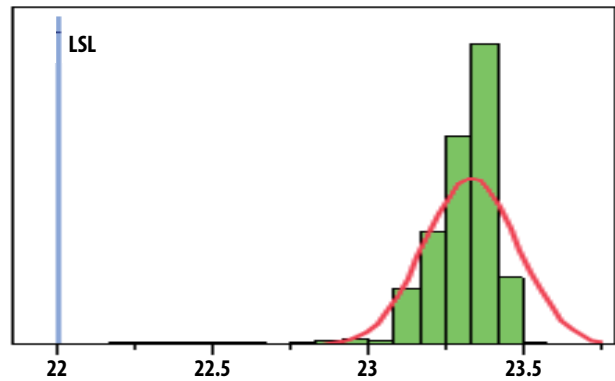

Figure 6. OP1dB @ 900 MHz, Vdd1 = 5 V, Vdd2 = 5 V, LSL = 22 dBm, Nominal = 23.3 dBm

Notes:

1. Data sample size is 10026 samples taken from 3 different wafers. Future wafers allocated to this product may have nominal values anywhere between the upper and lower limits.
2. Measurements are made on production test board which represents a trade-off between optimal Gain, NF, OIP3 and OP1dB. Circuit losses have been de-embedded from actual measurements.

Demo Board Layout

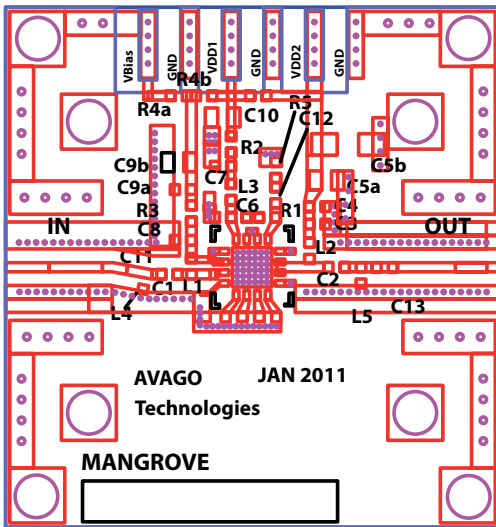

Figure 7. Demo Board layout diagram.

Demo Board Schematic

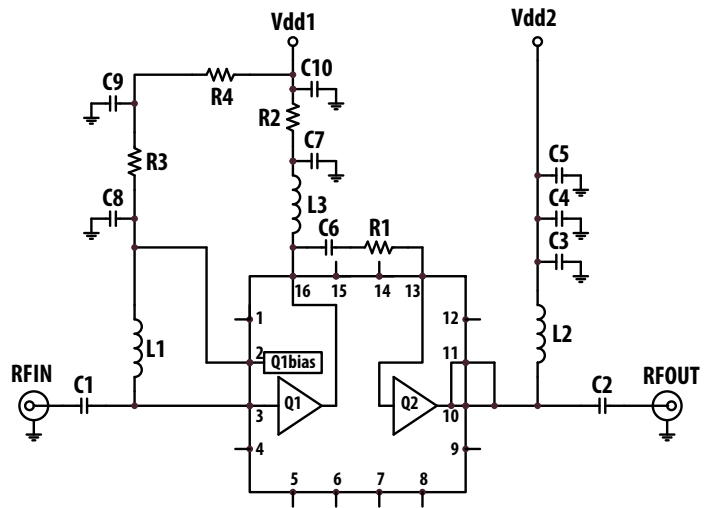

Figure 8. Demo Board schematic diagram.

- Recommended PCB material is 10 mils Rogers R04350.
- Suggested component values may vary according to layout and PCB material.

Table 1. Component list for 900MHz matching

Part	Size	Value	Detail Part Number	Notes
C1, C6	0402	100pF (Murata)	GRM1555C1H101JD01E	DC Blocking Capacitors
C2	0402	12pF (Murata)	MCH155A120JK	DC Blocking Capacitor
C3	0402	10pF (Murata)	GRM1555C1H100JZ01E	Bypass Capacitor
C4	0402	0.1uF (Murata)	GRM155R61A104KA01D	Bypass Capacitor
C5a	0603	2.2uF (Murata)	GRM188R61A225KE34D	Bypass Capacitor
C7	0402	33pF (Murata)	GRM1555C1H330JZ01E	Bypass Capacitor
C9a, C9b	N/A	Not used	Not used	Bypass Capacitor
C8, C10	0402	4.7uF (Murata)	GRM155R60E475ME760	Bypass Capacitors
L1	0402	18nH (Toko)	LL1005-FHL18NJ	Input Match for NF
L2	0402	39nH (Toko)	LL1005-FHL39NJ	Output match for Q2
L3	0402	39nH (Toko)	LL1005-FHL39NJ	Output match for Q1
R3, R1	0402	0 ohm (Koa)	RK73Z1ELTP	Bridging Resistors
R2	0402	10 ohm (Rohm)	MCR01J100	Stabilizing Resistor for Q1
R4b	0402	6.8K ohm (Koa)	RM73B1E682J	Biasing Resistor for Q1

MGA-13116 Typical Performance in Demoboard for 900 MHz

$T_A = 25^\circ\text{C}$, $V_{dd1} = 5.0\text{V}$, $V_{dd2} = 5.0\text{V}$, $I_{dd1} = 55\text{mA}$, $I_{dd2} = 112\text{mA}$

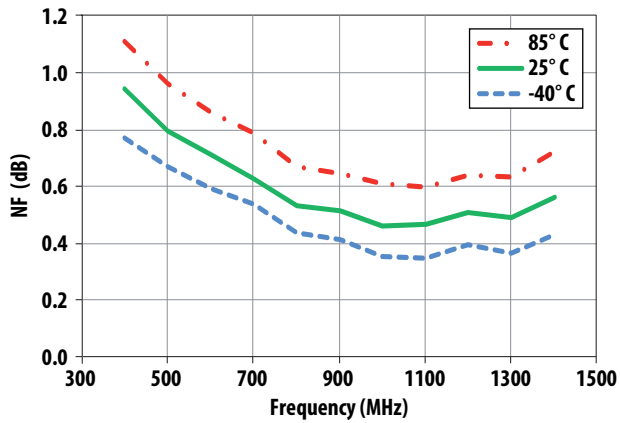

Figure 9. NF vs Frequency and Temperature

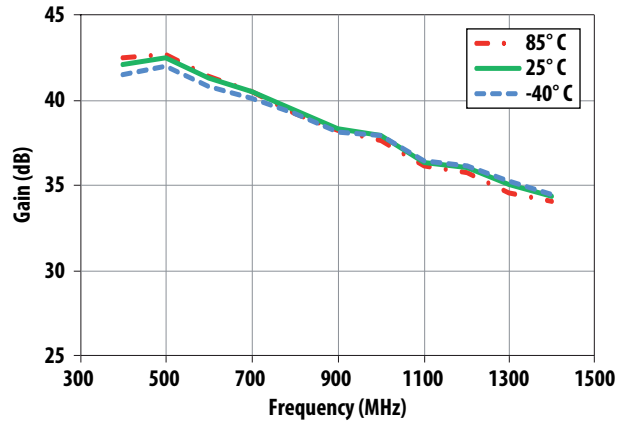

Figure 10. Gain vs Frequency and Temperature

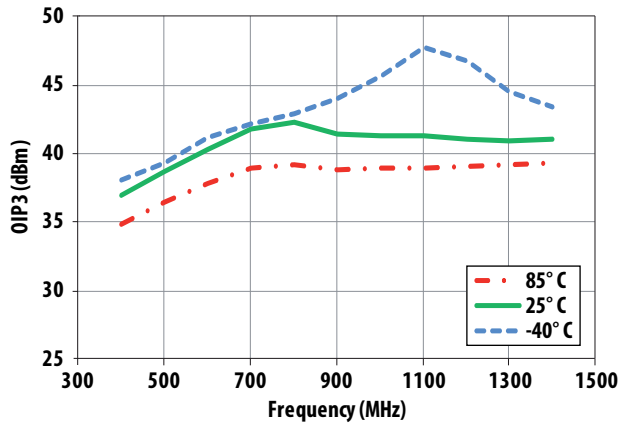

Figure 11. OIP3 vs Frequency and Temperature

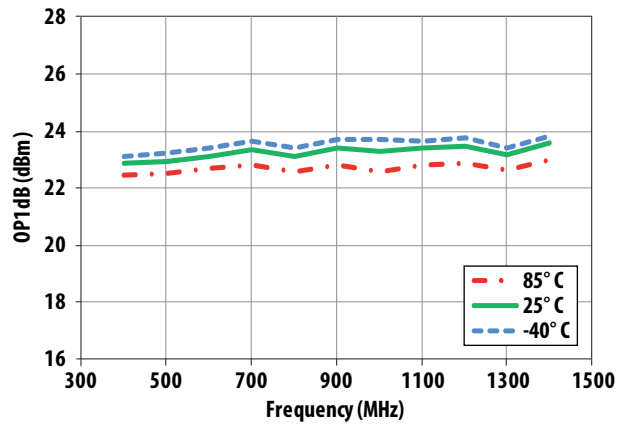

Figure 12. OP1dB vs Frequency and Temperature

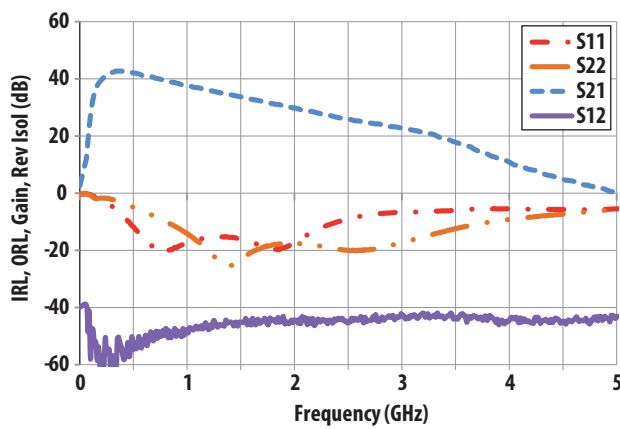

Figure 13. Input Return Loss, Output Return Loss, Gain, & Reverse Isolation vs Frequency

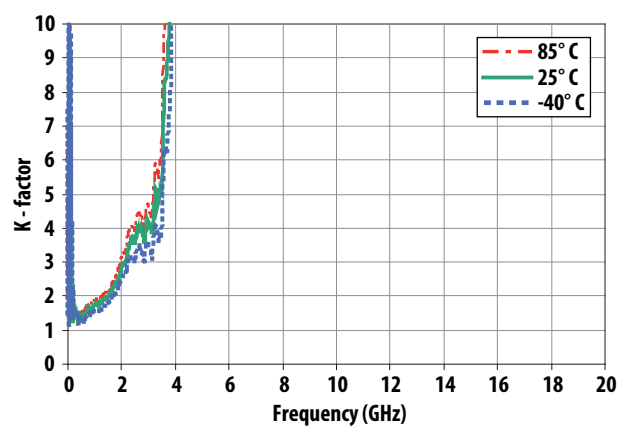

Figure 14. K-factor vs Frequency and Temperature

MGA-13116 Typical Performance in Demoboard for 900 MHz

$T_A = 25^\circ\text{C}$, $V_{dd1} = 5.0\text{V}$, $V_{dd2} = 5.0\text{V}$, $I_{dd1} = 55\text{mA}$, $I_{dd2} = 112\text{mA}$

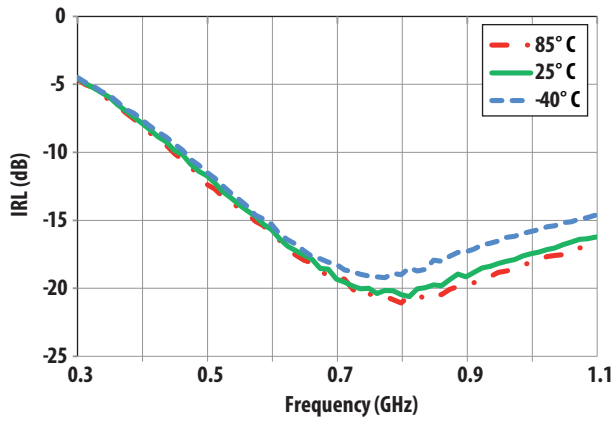

Figure 15. IRL vs Frequency and Temperature

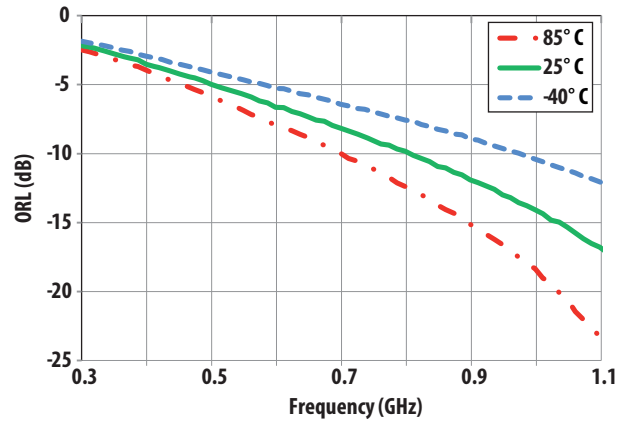

Figure 16. ORL vs Frequency and Temperature

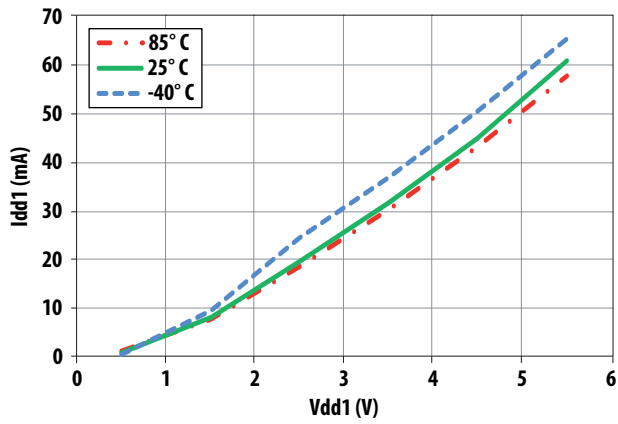

Figure 17. Idd1 vs Vdd1 and Temperature

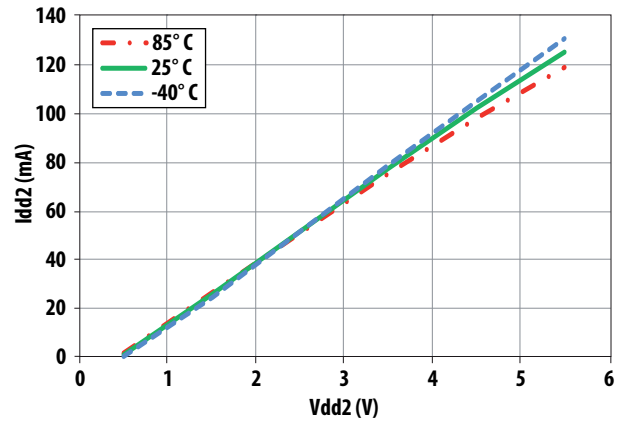

Figure 18. Idd2 vs Vdd2 and Temperature

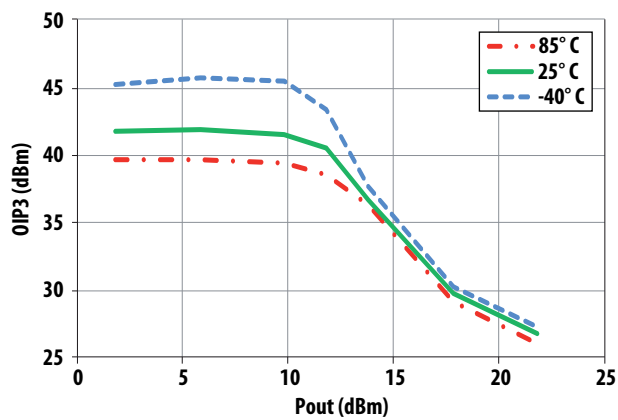

Figure 19. OIP3 vs Output Power and Temperature at 900 MHz

MGA-13116 Q1 Typical Scattering Parameters, Vdd1 = 5 V, Idd1 = 55 mA

Freq GHz	S11		S21		S12		S22	
	Mag.	Ang.	Mag.	Ang.	Mag.	Ang.	Mag.	Ang.
0.1	0.74	-41.90	28.09	145.39	0.02	63.40	0.29	-39.30
0.5	0.22	-84.68	11.81	105.49	0.05	60.13	0.14	1.62
0.9	0.14	-101.78	7.39	86.79	0.09	60.17	0.18	-12.75
1.0	0.13	-106.05	6.74	83.14	0.09	59.45	0.18	-16.99
1.5	0.10	-128.01	4.69	67.16	0.14	53.73	0.18	-35.56
1.9	0.09	-140.02	3.77	56.17	0.17	47.97	0.17	-50.36
2.0	0.09	-142.35	3.60	53.51	0.18	46.51	0.16	-53.64
2.5	0.08	-154.03	2.93	41.20	0.22	38.81	0.16	-73.64
3.0	0.06	-173.46	2.49	29.38	0.26	30.55	0.15	-91.93
4.0	0.04	129.28	1.92	6.91	0.33	13.36	0.12	-151.01
5.0	0.04	120.65	1.58	-14.44	0.40	-4.62	0.19	158.26
6.0	0.05	84.36	1.34	-35.13	0.45	-22.97	0.26	121.64
7.0	0.05	29.33	1.14	-54.64	0.48	-41.22	0.35	93.85
8.0	0.02	-178.29	0.99	-73.16	0.50	-59.29	0.43	81.24
9.0	0.10	169.39	0.88	-93.10	0.52	-79.56	0.46	62.32
10.0	0.10	178.95	0.74	-111.93	0.50	-99.40	0.45	33.79
11.0	0.13	134.83	0.65	-125.11	0.49	-114.26	0.54	25.75
12.0	0.28	108.23	0.61	-140.87	0.50	-131.91	0.65	19.97
13.0	0.49	103.82	0.51	-157.73	0.45	-151.15	0.62	18.93
14.0	0.62	94.39	0.43	-170.19	0.40	-166.05	0.69	11.24
15.0	0.71	71.83	0.37	172.53	0.36	174.21	0.79	-1.76
16.0	0.81	44.07	0.29	154.33	0.28	153.44	0.82	-10.61
17.0	0.87	17.53	0.20	139.72	0.20	136.55	0.82	-23.84
18.0	0.81	-19.41	0.11	165.37	0.11	162.20	0.89	-42.58
19.0	0.18	29.76	0.34	154.36	0.37	148.88	0.77	-60.35
20.0	0.82	19.19	0.26	126.89	0.27	117.97	0.85	-46.54

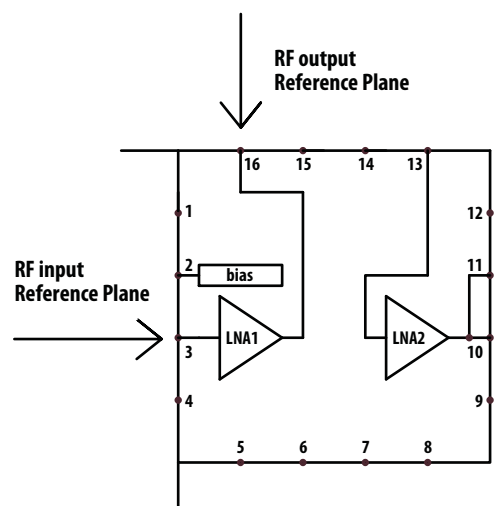

Figure 20.

MGA-13116 Q1 Typical Noise Parameters, Vdd1 = 5 V, Idd1 = 55 mA

Freq GHz	Fmin dB	Γ_{opt} Mag.	Γ_{opt} Ang.	Rn/50
0.50	0.39	0.090	-21.8	0.0428
0.70	0.35	0.143	-39.2	0.0474
0.75	0.42	0.098	-48.2	0.0378
0.80	0.39	0.054	5.9	0.0402
0.90	0.42	0.064	7.3	0.0402
1.50	0.55	0.068	4.1	0.0538
1.70	0.60	0.074	70.4	0.0492
1.95	0.70	0.097	149	0.0392

Notes: Measurements are made on 10 mils Rogers R04350 TRL Board. Figure 20 shows the input and output reference plane for Q1.

MGA-13116 Q2 Typical Scattering Parameters, Vdd2 = 5 V, Idd2 = 112 mA

Freq GHz	S11		S21		S12		S22	
	Mag.	Ang.	Mag.	Ang.	Mag.	Ang.	Mag.	Ang.
0.1	0.20	-171.18	11.59	167.44	0.04	0.06	0.49	176.27
0.5	0.22	157.18	11.23	138.79	0.04	-13.51	0.43	147.50
0.9	0.23	129.26	10.61	107.30	0.04	-28.06	0.30	129.04
1.0	0.23	120.60	10.45	99.56	0.04	-32.25	0.27	125.80
1.5	0.21	58.66	9.71	60.61	0.04	-58.34	0.12	129.80
1.9	0.26	-20.17	9.13	27.17	0.04	-88.98	0.12	176.29
2.0	0.30	-38.51	8.93	18.19	0.03	-98.40	0.14	179.35
2.5	0.59	-108.72	7.28	-28.35	0.03	-156.55	0.22	161.20
3.0	0.81	-159.33	5.00	-72.18	0.03	144.59	0.21	118.27
4.0	0.94	137.68	1.99	-137.97	0.03	89.64	0.22	-7.02
5.0	0.95	104.26	0.81	169.65	0.04	77.06	0.49	-86.96
6.0	0.93	79.07	0.32	123.70	0.05	57.14	0.69	-128.37
7.0	0.94	59.92	0.15	87.16	0.05	38.07	0.67	-154.44
8.0	0.96	44.90	0.09	55.20	0.06	23.86	0.65	-172.62
9.0	0.92	25.09	0.07	26.64	0.05	9.36	0.70	178.48
10.0	0.91	13.25	0.05	9.11	0.05	-1.10	0.73	168.17
11.0	0.93	11.43	0.03	2.49	0.04	-8.69	0.75	154.12
12.0	0.93	3.64	0.02	0.78	0.03	-24.56	0.78	135.37
13.0	0.81	-10.41	0.01	29.86	0.02	-45.74	0.82	116.24
14.0	0.90	-22.26	0.02	59.46	0.01	-137.08	0.80	94.18
15.0	0.99	-28.29	0.02	63.39	0.03	134.73	0.80	73.17
16.0	0.96	-29.34	0.04	107.89	0.06	111.70	0.75	60.30
17.0	0.95	-38.67	0.09	96.45	0.10	94.24	0.68	43.03
18.0	0.91	-58.96	0.18	70.31	0.18	69.07	0.67	12.84
19.0	0.81	-78.56	0.30	19.69	0.30	19.67	0.58	-39.24
20.0	0.65	-58.97	0.20	-20.26	0.21	-20.60	0.45	9.78

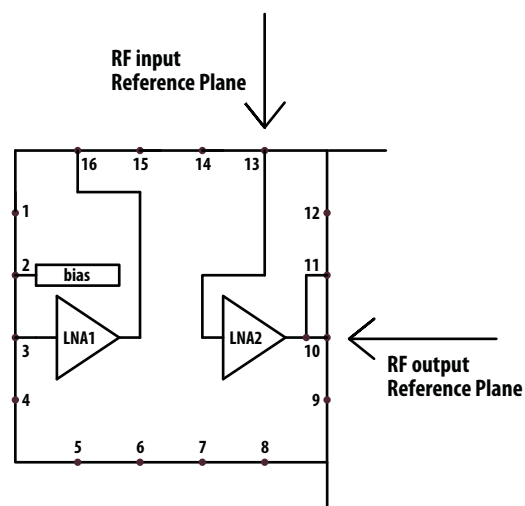

Figure 21.

MGA-13116 Q2 Typical Noise Parameters, Vdd2 = 5 V, Idd2 = 112 mA

Freq GHz	Fmin dB	Γ_{opt} Mag.	Γ_{opt} Ang.	Rn/50
0.50	1.70	0.165	-13.2	0.2946
0.70	1.76	0.129	-2.3	0.2590
0.75	1.76	0.11	-8.7	0.2528
0.80	1.69	0.129	-3.4	0.2526
0.90	1.63	0.108	2.7	0.2392
1.50	1.82	0.079	23.2	0.2460
1.70	1.90	0.116	65.2	0.2350
1.95	1.88	0.133	88.7	0.2376

Notes: Measurements are made on 10 mils Rogers R04350 TRL Board. Figure 21 shows the input and output reference plane for Q2.

Package Dimensions

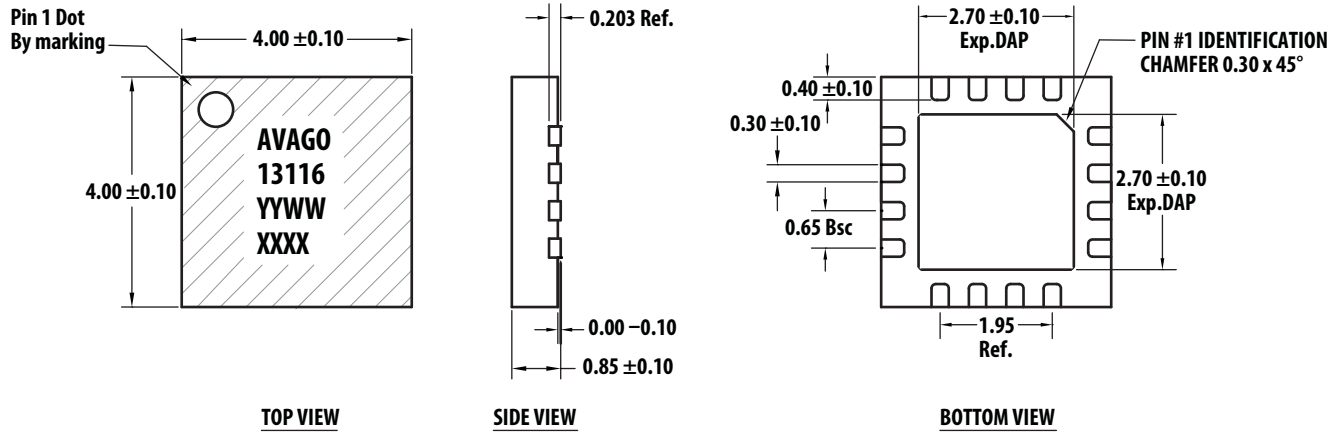

PCB Land Patterns and Stencil Design

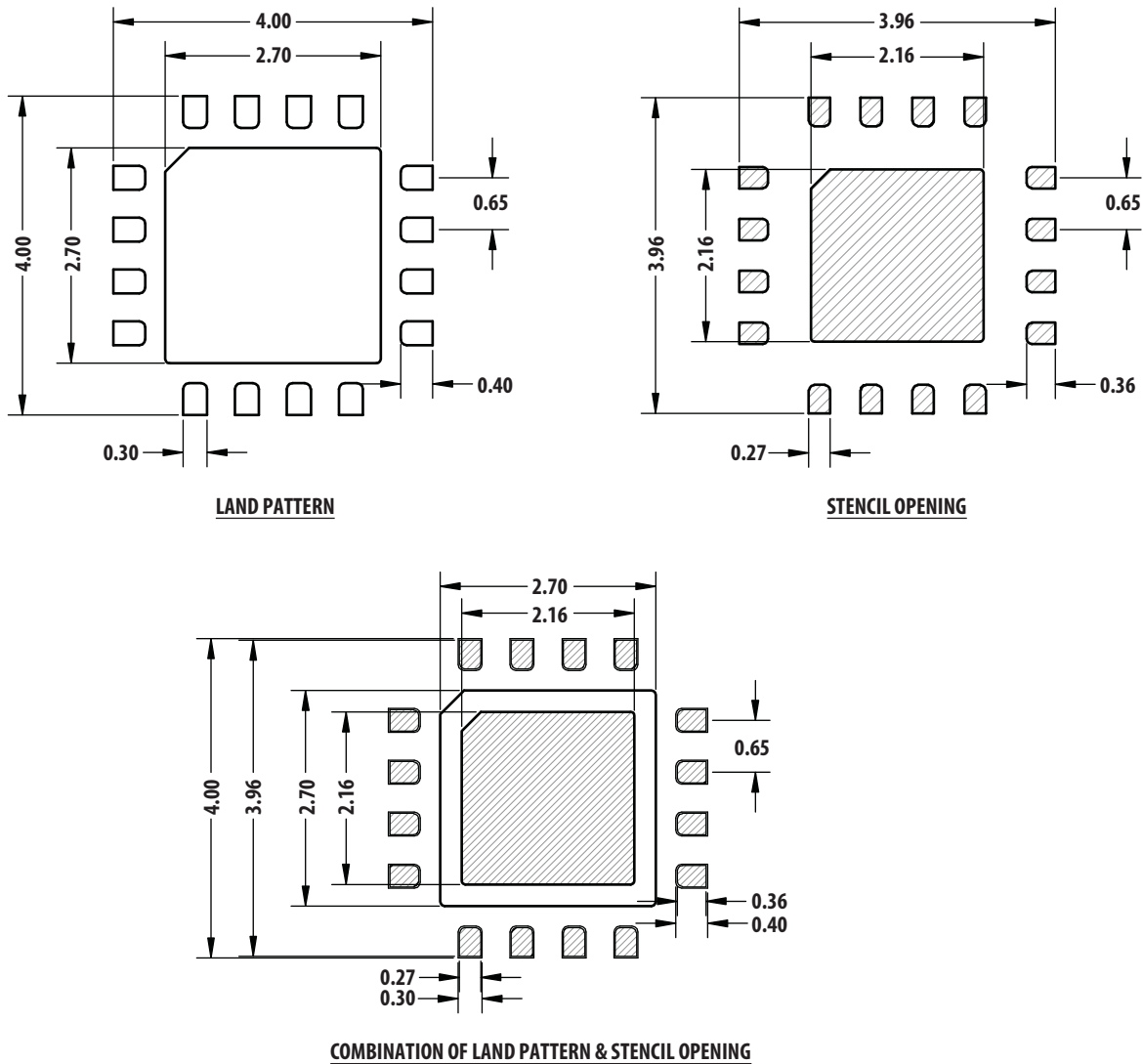

Notes:

1. All dimensions are in millimeters.
2. 4 mil stencil thickness recommended.

Device Orientation

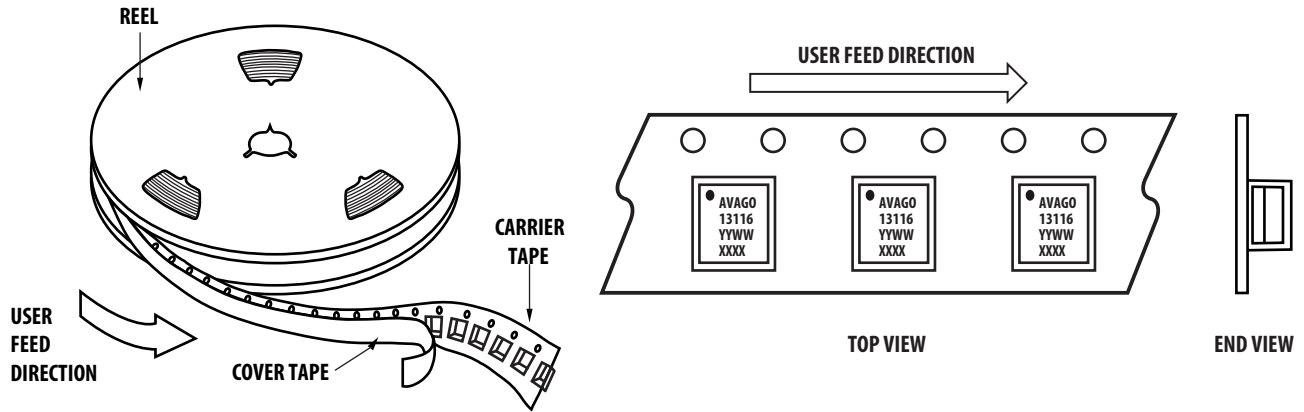

Tape Dimensions

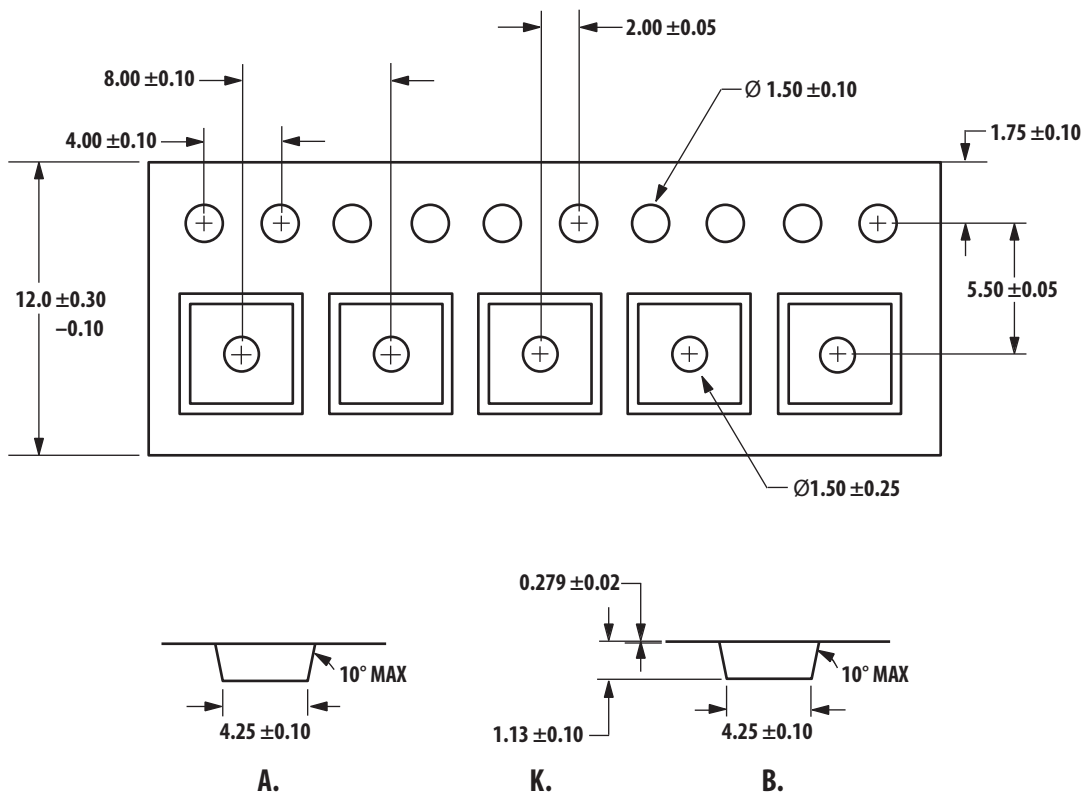

Part Number Ordering Information

Part Number	No. of Devices	Container
MGA-13116-TR1G	1000	7" Reel
MGA-13116-BLKG	100	antistatic bag

Reel Dimensions (7 inch reel)

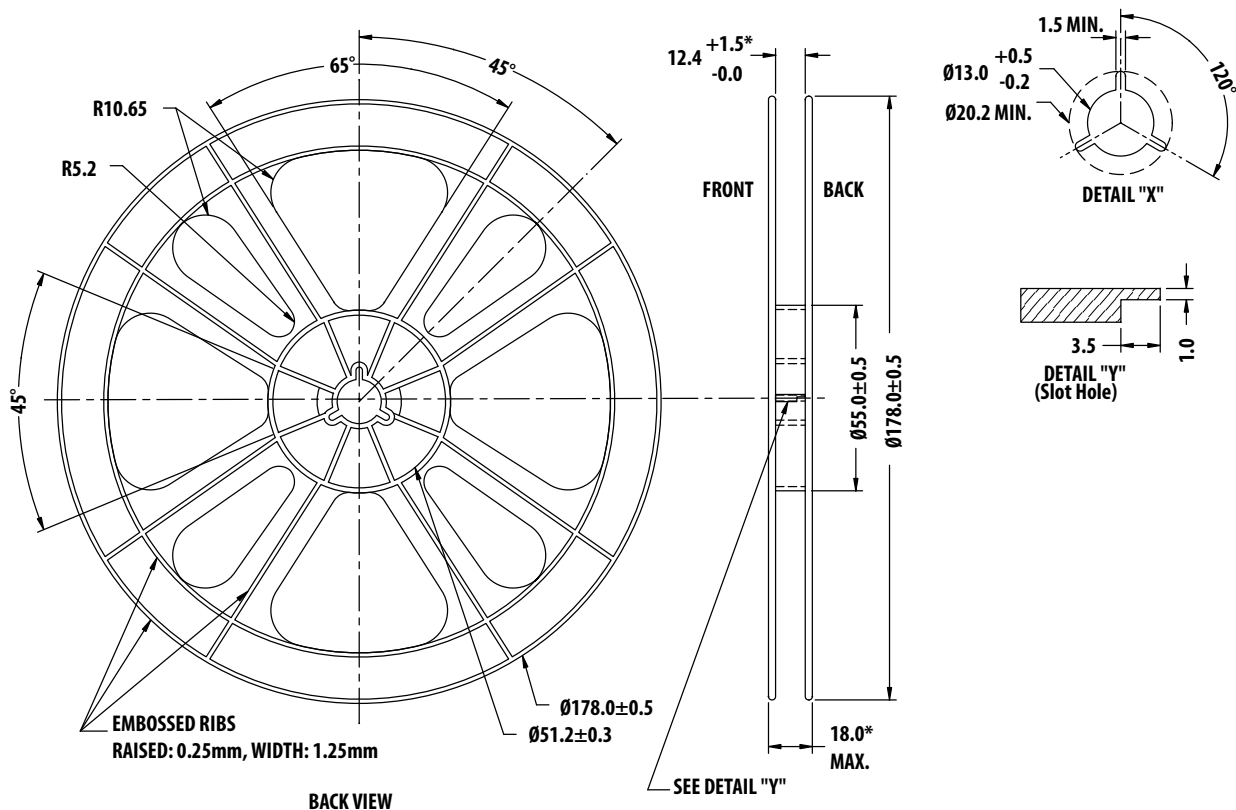
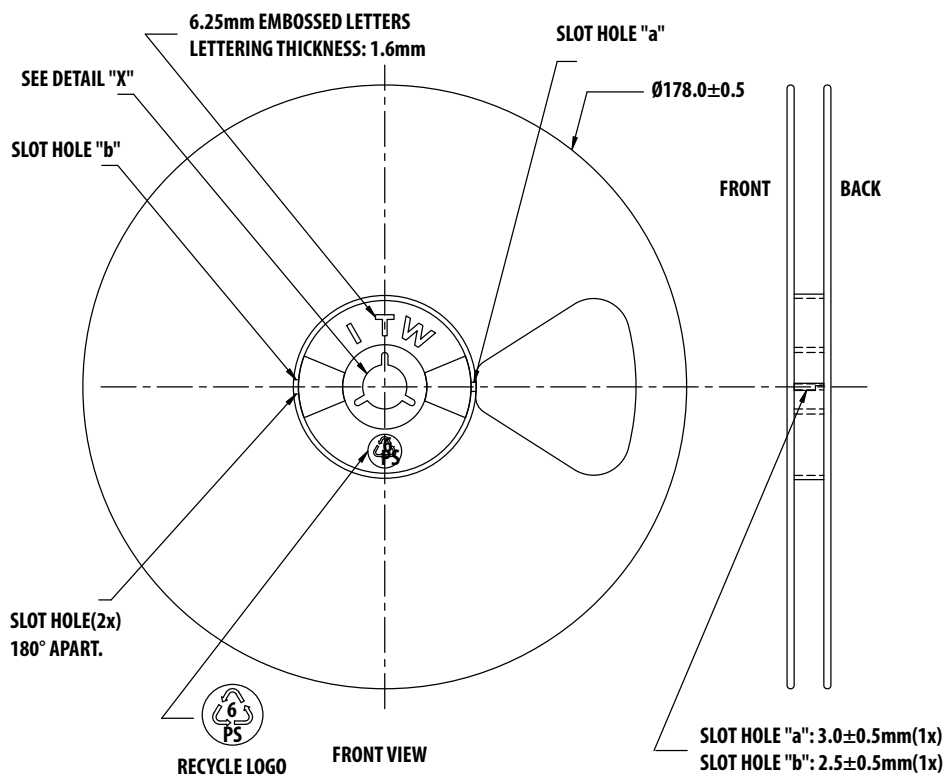

For product information and a complete list of distributors, please go to our web site: www.avagotech.com

Avago, Avago Technologies, and the A logo are trademarks of Avago Technologies in the United States and other countries.
Data subject to change. Copyright © 2005-2011 Avago Technologies. All rights reserved.
AV02-2877EN - December 19, 2011



Mouser Electronics

Authorized Distributor

Click to View Pricing, Inventory, Delivery & Lifecycle Information:

[Avago Technologies:](#)

[MGA-13116-BLKG](#) [MGA-13116-TR1G](#) [MGA-13116-TR2G](#)