

System Power Supply for TV Series

FET Controller Type 3ch System Power Supply ICs



BD8628EFV, BD8624EFV

No.09034EAT06

●Description

BD8628EFV / BD8624EFV have realized the high performance and reliability required as a power supply for thin-screen TV.

With built-in FET 1ch current mode control, the DC/DC Converter series has the advantage of high-speed load response and wide phase margin.

Due to the high-speed load response, it is most suitable for TV-purpose processors with increasingly high performance, and due to the wide phase margin it leaves a good margin for board pattern & constant setting and so facilitates its application design.

As a high-reliability design, it has various built-in protection circuits (overcurrent protection, output voltage abnormal protection, thermal protection, and off-latch function at the time of abnormality etc.), therefore as an advantage it does not easily damage in every possible abnormal condition such as all-pin short circuit test etc. and hence most suitable for thin-screen TV which requires the high reliability.

●Features

- 1) 11ch synchronous rectification step-down system DC/DC converter
- 2) Soft start, soft off function
- 3) Built-in low voltage / overvoltage protection function
- 4) Built-in overcurrent protection function
- 5) Frequency setting by external resistance is available. (RT terminal)
- 6) Protection time setting by external resistance is available. (RSET terminal)
- 7) Built-in RT / RSET terminal open/short protection function
- 8) Protection control with built-in sequencer
- 9) Built-in adjustment function time of off latch
- 10) Built-in error state detection signal output function
- 11) Built-in tracking function
- 12) Corresponded to protecting bus
- 13) Load current Maximum 3A
- 14) HTSSOP-B24 Package

●Electric characteristic

(Ta=25°C, VCC=6.5V, GND=0V, CTL=6.5V unless otherwise specified.)

Parameter	Symbol	specification value			UNIT	Condition
		MIN	TYP	MAX		
Circuit current 1	I _{Q1}	-	0	10	μA	CTL=0V
Circuit current 2	I _{Q2}	-	3.4	-	mA	CTL=VCC
< Error amplifier part >						
Standard voltage (VREF)	V _{REF}	0.792	0.8	0.808	V	Terminal FB and FC terminal short
Terminal FB Input bias current	I _{FB}	-1	0	1	μA	V _{FB} =0.9V
Terminal FC Clamping voltage H	V _{FCH}	1.8	-	-	V	V _{FB} =0.7V
Terminal FC Clamping voltage L	V _{FCL}	-	-	0.2	V	V _{FB} =0.9V
Terminal FC Sink current	I _{FC} SINK	0.5	-	-	mA	V _{FB} =0.9V, V _{FC} =0.4V
Terminal FC Source current	I _{FC} SOURCE	-	-	-70	μA	V _{FB} =0.7V, V _{FC} =1.6V
Open loop gain	A _{VERR}	-	100	-	dB	
<OSC part>						
Oscillation frequency	F _{OSC}	400	500	600	kHz	When terminal RT 27kΩ is connected
<Soft start >						
Charging current	I _{SS}	-3	-2.5	-2	μA	V _{SS} =1.0V
Terminal SS Threshold voltage	V _{SSTH}	0.98	1.08	1.18	V	V _{SS} Voltage
Terminal SS Clamping voltage	V _{SSCLM}	2.2	2.4	-	V	
Terminal SS Standby voltage	V _{SSSTB}	0.1	0.15	-	V	V _{SS} Voltage (L to H)
Terminal SS Discharge resistance	R _{SS}	49	70	91	kΩ	CTL=0V
Terminal SS Protection circuit start voltage	V _{SSPON}	1.0	1.1	1.2	V	V _{SS} Voltage (L to H)
Terminal SS Protection circuit start voltage Maximum hysteresis error	V _{SSPON_HYS}	10	100	200	mV	V _{SS} Voltage
< Low voltage, over voltage detection part>						
Terminal FB Low voltage detection voltage	V _{LVP}	0.51	0.56	0.61	V	V _{FB} Voltage
Terminal FB Overvoltage detection voltage	V _{OVP}	0.86	0.96	1.06	V	V _{FB} Voltage
< Over current detection part>						
Output current limitation threshold	I _{limt}	VCC-0.9	VCC-0.7	VCC-0.5	V	V _{SW} Voltage
<Power MOS>						
Upper side MOS ON resistance	R _{ONU}	-	110	-	mΩ	V _{BOOT} -V _{SW} =5V
Lower side MOS ON resistance	R _{ONL}	-	110	-	mΩ	V _{VREG5} =5V
<Others>						
Terminal PDET L output voltage	V _{OL_PDET}	-	-	0.4	V	I _{OL} =100μA
Terminal CTL input voltage H level voltage	V _{IH_CTL}	2.0	-	VCC	V	CTL terminal
Terminal CTL input voltage L level voltage	V _{IL_CTL}	-	-	0.5	V	CTL terminal
Terminal CTL input current	I _{L_CTL}	-	60	90	μA	CTL terminal, CTL=VCC

V_{FB} : FB terminal voltage, V_{FC} : FC terminal voltage, V_{SS} : SS terminal voltage, V_{MONVCC} : MONVCC terminal voltage

Not designed for radiation resistance.

Current capability should not exceed Pd.

Permissible loss

This package is a product of which the feature is the high heat radiation, and connect the back to GND based on recommended land pattern when you mount.

θ_{jc} [°C /W]	θ_{ja} [°C /W]	T_{STGmin} [°C]	T_{STGmax} [°C]	$T_{a min}$ [°C]	$T_{a max}$ [°C]	T_{cmax} Destruction temperature [°C]	T_{jmax} Destruction temperature [°C]
19.0	31.3	-50.0	150.0	-45.0	85.0	150.0	150.0

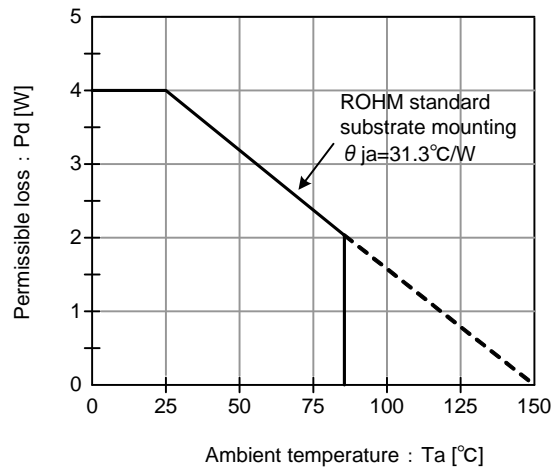

ROHM standard substrate specification
 Material 4 layer glass epoxy substrate(back copper foil70mm x 70mm)
 Size 70mm x 70mm x 1.6mmt(Sarmalbiaing is in the substrate.)

Figure.1 Heat decrease curve

※These values are the actual measurement values, and no guarantee values.

●Block diagram

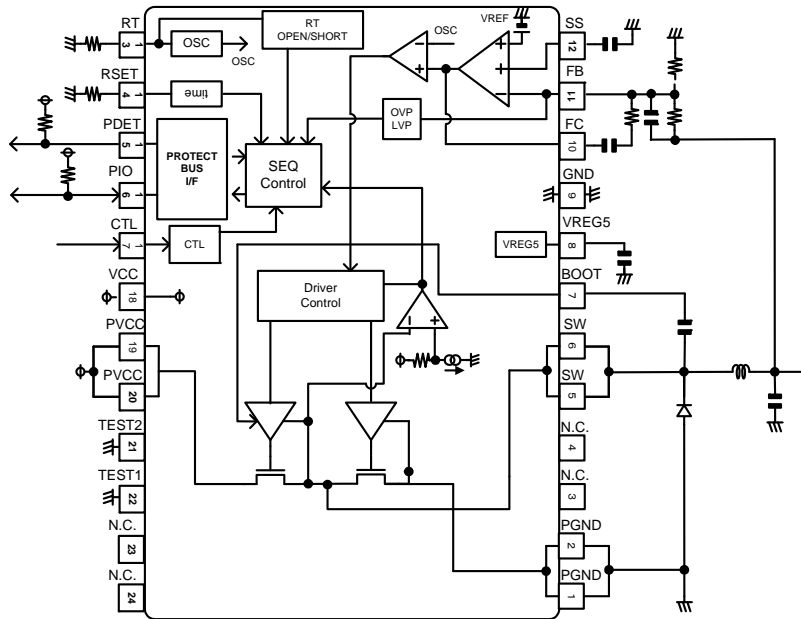

Figure.2 Block diagram, Application diagram

●Terminal explanation

Table 1 Terminal explanation

No.	Symbol	Description	No.	Symbol	Description
1	PGND	Power GND terminal	13	RT	Frequency adjustment resistance connection terminal
2	PGND	Power GND terminal	14	RSET	Off latch effective time adjustment resistance terminal
3	N.C.	No wire connection. (Connect to GND.)	15	PDET	Error state notification terminal
4	N.C.	No wire connection. (Connect to GND.)	16	PIO	Error state notification and external IC error detection terminal
5	SW	SW terminal	17	CTL	Enable input
6	SW	SW terminal	18	VCC	VCC power supply terminal
7	BOOT	High side Power MOS gate drive power source terminal	19	PVCC	Power VCC terminal
8	VREG5	Internal power supply (5.0V) output terminal	20	PVCC	Power VCC terminal
9	GND	GND	21	TEST2	Test terminal (Connect to GND.)
10	FC	Phase amends terminal	22	TEST1	Test terminal (Connect to GND.)
11	FB	Feedback terminal	23	N.C.	No wire connection. (Connect to GND.)
12	SS	Soft start adjustment capacity connection terminal	24	N.C.	No wire connection. (Connect to GND.)

※Please give to VCC+0.3V as an operation condition in all input terminals except the terminal BOOT. However, please do not exceed the absolute maximum rating as VCC=PVCC.

● Terminal equivalent circuit chart

Terminal No.	Terminal name	Explanation	Terminal equivalent circuit chart
1	PGND	Power GND (The same potential as the GND terminal)	
2	PGND	Power GND (The same potential as the GND terminal)	
5	SW	SW terminal	
6	SW	SW terminal	
7	BOOT	High side Power MOS gate drive power source terminal	
8	VREG5	Internal power supply (5.0V) output terminal	
9	GND	GND	
10	FC	Phase amends terminal	

Terminal No.	Terminal name	Explanation	Terminal equivalent circuit chart
11	FB	Voltage detection terminal	
12	SS	Soft start adjustment capacity connection terminal	
13	RT	Frequency adjustment resistance connection terminal	
14	RSET	Off latch effective time adjustment resistance terminal	
15	PDET	Error state notification terminal	

Terminal No.	Terminal name	Explanation	Terminal equivalent circuit chart
16	PIO	Error state notification and external IC error detection terminal	
17	CTL	Enable input	
21	TEST2	Test terminal (Connect to GND.)	
22	TEST1	Test terminal (Connect to GND.)	
19	PVCC	Power VCC terminal	
20	PVCC	Power VCC terminal	

●Operation description

ON/OFF control

DC/DC converter ON/OFF function

DC/DC converter controller can be controlled ON/OFF by CTL terminal.

Analog circuit starts operation at ON control (on mode), and goes down to setting output voltage.

Analog circuit should be standby at OFF control (off mode), and output voltage becomes 0V.

Table2 DC/DC converter ON/OFF function

CTL terminal voltage	
>VIHCTL	ON control
<VILCTL	OFF control

Soft start time set function

DC/DC converter can do soft start without overshoot by charging soft start capacity (C_{SS}) connected between SS terminal and GND by charging current at ON control.

The mute of the output is released when it reaches V_{SS}=0.15V (V_{SSSTB}), and the output voltage does the soft start operation from the point of V_{SS}=0.3V (typ) in proportion to the voltage of the terminal SS.

Also, soft start time (t_{SS}) can be set by setting soft start capacity arbitrarily.

Soft start time (t_{SS}) should be set at 3msec < t_{SS} < 30msec.

※Please note that the overshoot is not caused in the output setting voltage when setting it to t_{SS} ≤ 3msec.

$$t_{SS} = \frac{V_{SSTH} \times C_{SS}}{I_{SS}}$$

Discharge function

DC/DC converter can do soft off by discharging load discharged to soft start capacity connected between SS terminal to GND by discharging resistance at OFF control.

Soft off operates in proportion to the voltage of the terminal SS the output voltage from the point of V_{SS}=0.8V (typ).

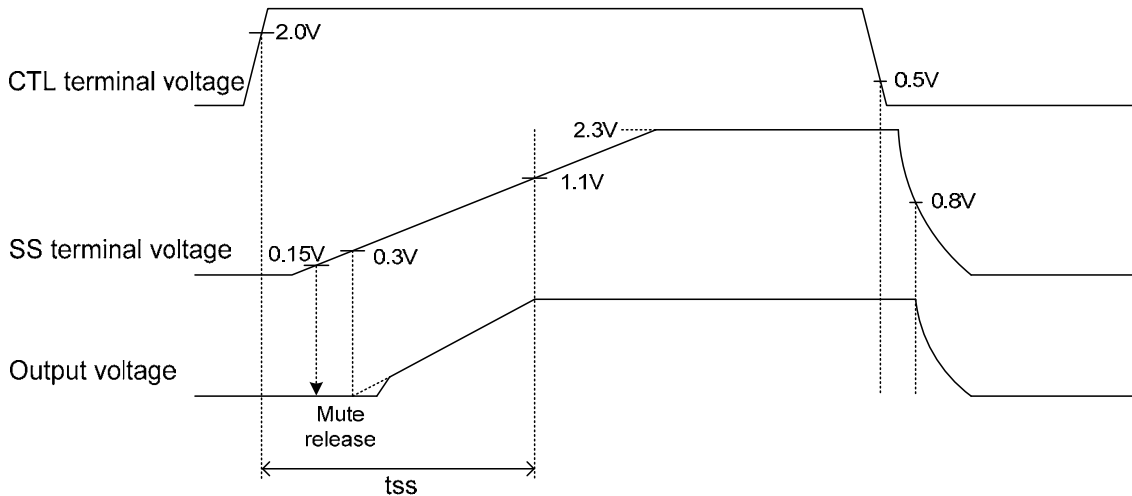

Figure.3 Wave form at ON/OFF control

OSC oscillation frequency setting function

SW output oscillation frequency of DC/DC converter can be set by installing resistance between RT terminal and GND externally.

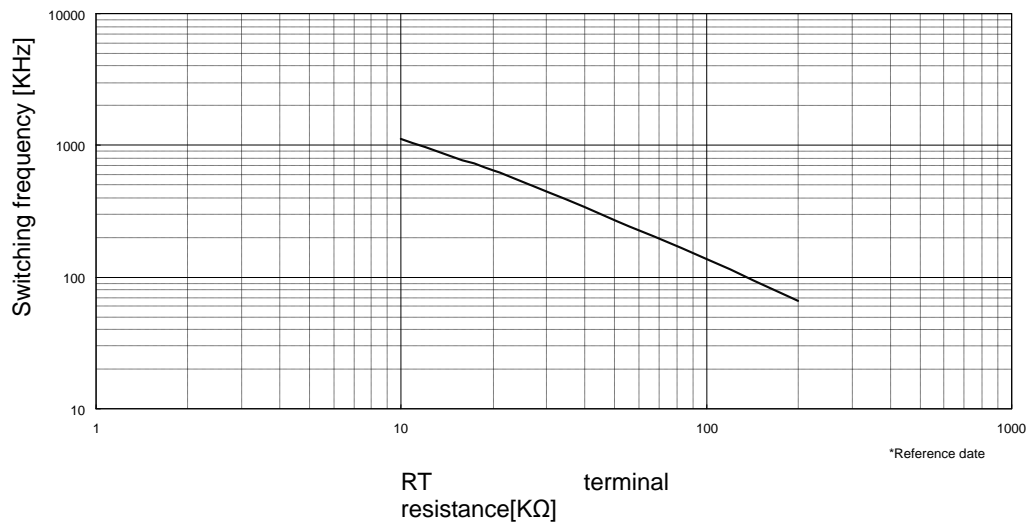

Figure.4 Terminal RT resistance-oscillation frequency

Range of terminal RT connection resistance setting

$$23\text{k}\Omega \leq R_{rt} \leq 135\text{k}\Omega$$

$$(100\text{kHz} \leq f_{osc} \leq 600\text{kHz})$$

PROTECT BUS Input/output function

The terminal PIO is PROTECT BUS Input/output terminal. The terminal PIO is Hi-Z when DC/DC usually operates. When the terminal PIO becomes LOW by connecting PROTECT BUS, DC/DC is turned off. Afterwards, when the terminal PIO becomes HIGH, it reactivates.

DC/DC is Off latch when DC/DC error detects it and the terminal PDET becomes LOW.

Table3 PIO terminal, PDET terminal output function

DC/DC Error detection	PIO terminal	PDET terminal	DC/DC
Undetection	Hi-Z	Hi-Z	ON
Undetection	LOW	Hi-Z	OFF
Detection	LOW	LOW	Off latch

PROTECT BUS Timing chart

If two or more BD8628EFV//BD8624FV is connected in PROTECT BUS, and it uses at the same time, when one IC error detects, all remaining IC becomes PIO = Low at the same time, and the output is turned off.

Protecting BUS part timing chart

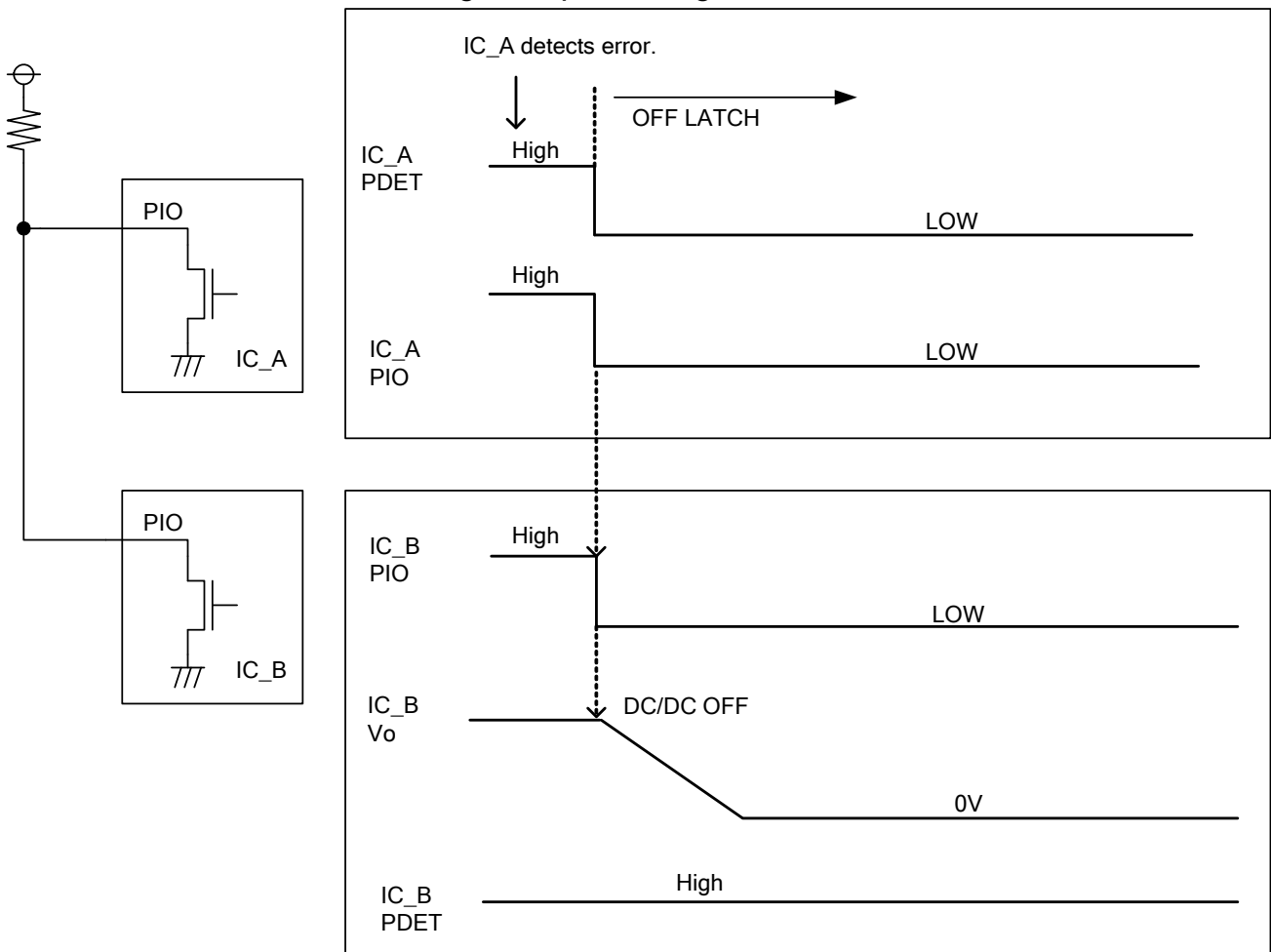

When two or more BD8628EFV//BD8624FV is used at the same time, If one IC error detects, all IC becomes DC/DC OFF at the same time.

●Protection function

Protection circuit is effective for destruction prevention due to accident so that avoid using by continuous protection operation.

Low voltage protection function(LVP)

Low voltage protection function detects set output voltage VO from FB terminal and off-latched DC/DC converter compared to internal reference level.

Low voltage protection function operates when FB terminal voltage falls below VLVP (=0.7 x VREF) and continues more than set time in external resistance.

Table 4 Low voltage protection function

CTL terminal	SS terminal	FB terminal	Low voltage protection function	Low voltage protection operation
>VIHCTL	>1.1V(typ)	<VLVP	Enable	ON
		>VLVP+VLVP_HYS		OFF
	<1.0V(typ)	-	Disable	OFF
<VILCTL	-	-	Disable	OFF

※Constant voltage protection function is enabled when SS terminal voltage becomes more than 1.1V (typ) in the transition to ON control (during soft start).

Overvoltage protection function (OVP)

Overvoltage protection function detects set output voltage VO from FB terminal and off-latched DC/DC converter controller compared to internal reference level.

Overvoltage protection function operates when FB terminal voltage exceeds VOVP (=1.2 x VREF) and continues more than set time in external resistance.

Table 5 Overvoltage protection function

CTL terminal	SS terminal	FB terminal	Overvoltage protection function	Overvoltage protection operation
>VIHCTL	>1.1V(typ)	>VOVP	Enable	ON
		<VOVP		OFF
	<1.0V(typ)	-	Disable	OFF
<VILCTL	-	-	Disable	OFF

※Overvoltage protection function is enabled when SS terminal voltage of each Ch becomes more than 1.1V (typ) in the transition to ON control (during soft start).

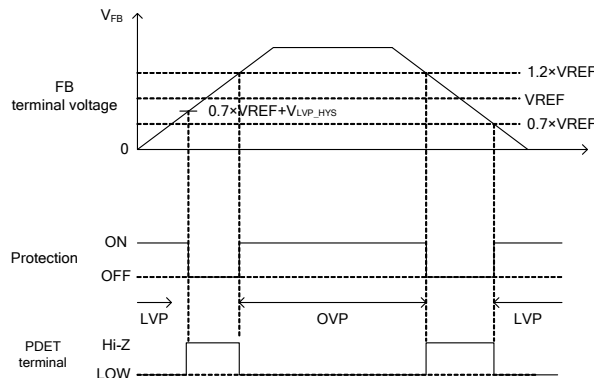

Figure.5 Low voltage / overvoltage protection

Overcurrent protection function (OCP)

Overcurrent protection function compared drain voltage (LX terminal voltage) with internal OCP terminal voltage when internal Nch POWER MOS is ON. When LX terminal voltage becomes lower than OCP terminal voltage, external MOS would be OFF.

Off latch by overcurrent protection function operates when LX terminal voltage falls below OCP terminal voltage and continues more than set time in external resistance.

Table 6 overcurrent protection function

CTL terminal	SS terminal	Output current	Overcurrent protection function	Overcurrent protection operation
>VIHCTL	>1.1V(typ)	>I _{lmt}	Enable	ON
		<I _{lmt}		OFF
	<1.0V(typ)	-	Disable	OFF
<VILCTL	-	-	Disable	OFF

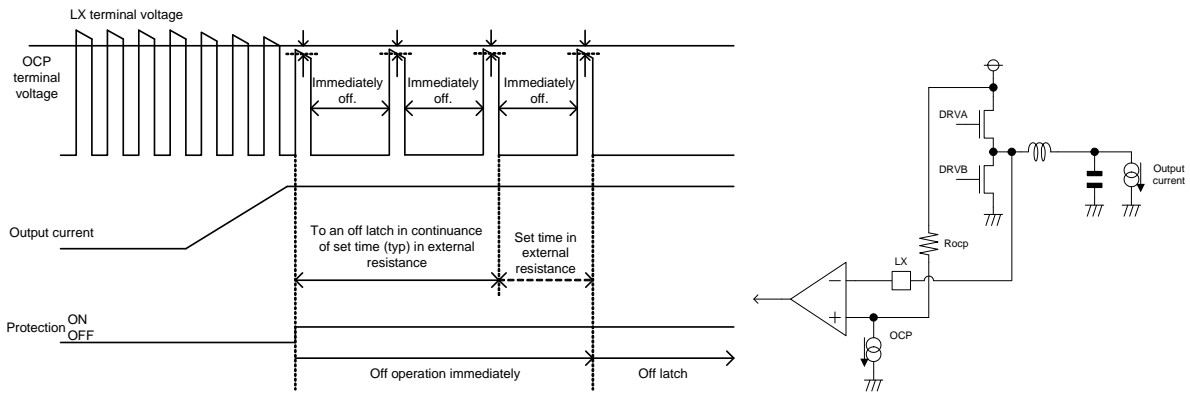

Figure.6 Overcurrent protection

RT terminal open/short protection function

RT terminal open/short protection function off-latches all DC/DC converter controller by detecting open/short condition internally from RT terminal to prevent from output voltage error caused by error oscillation of internal triangular wave at RT terminal open/short.

RT terminal open/short protection function is regularly enabled after boot-up.

RT terminal open/short protection function operates when error detection condition continues more than set time in external resistance.

Soft start time-out function

DC/DC converter off-latch-controls when V_{SS} does not exceed V_{SSPON} from V_{SS} > V_{SSSTB}+V_{SSSTB_HYS} after 50msec (typ) passed from soft start.

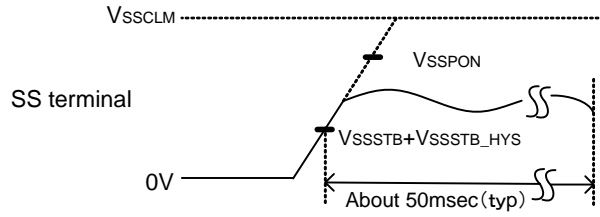

Figure.7 At soft start time-out

Error detection (off latch) release method

DC/DC converter becomes off latch condition when protection function operates. Off latch can be released by the following method. DC/DC converter controller of each Ch becomes able to do ON control transition by releasing off latch.

1. Set all Ch CTL terminal voltage as < V_{ILCTL} and continue that condition about more than 200usec (typ).
2. Drop down power supply VCC to below 2.7V(TYP).

Error detection time set function

Time from the error detection to the off latch can be set by putting resistance outside between GND and RSET terminal.

$$t_{\text{offlatch}} = 1.8 \times 10^{-3} \times R_{\text{rset}} \text{ [usec]}$$

Rset setting range

$$10\text{k}\Omega \leq R_{\text{set}} \leq 75\text{k}\Omega$$

$$(18\text{usec} \leq t_{\text{offlatch}} \leq 135\text{usec})$$

●Ordering part number

B	D
---	---

Part No

8	6	2	8
---	---	---	---

Part No.
8628
8624

E	F	V
---	---	---

Package
EFV: HTSSOP-B24

E	2
---	---

Packaging and forming specification
E2: Embossed tape and reel

HTSSOP-B24

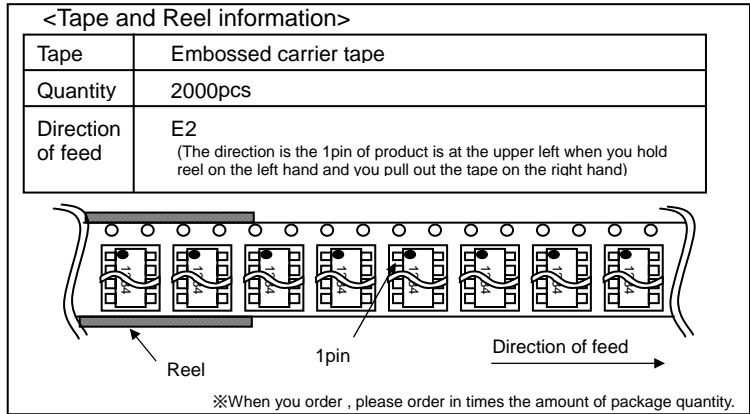
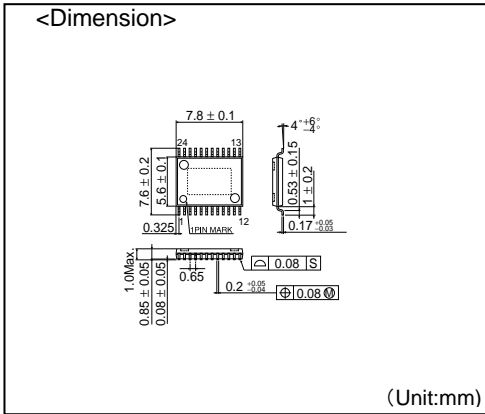

Notice

Precaution on using ROHM Products

- Our Products are designed and manufactured for application in ordinary electronic equipments (such as AV equipment, OA equipment, telecommunication equipment, home electronic appliances, amusement equipment, etc.). If you intend to use our Products in devices requiring extremely high reliability (such as medical equipment ^(Note 1), transport equipment, traffic equipment, aircraft/spacecraft, nuclear power controllers, fuel controllers, car equipment including car accessories, safety devices, etc.) and whose malfunction or failure may cause loss of human life, bodily injury or serious damage to property ("Specific Applications"), please consult with the ROHM sales representative in advance. Unless otherwise agreed in writing by ROHM in advance, ROHM shall not be in any way responsible or liable for any damages, expenses or losses incurred by you or third parties arising from the use of any ROHM's Products for Specific Applications.

(Note1) Medical Equipment Classification of the Specific Applications

JAPAN	USA	EU	CHINA
CLASS III	CLASS III	CLASS II b	CLASS III
CLASS IV		CLASS III	

- ROHM designs and manufactures its Products subject to strict quality control system. However, semiconductor products can fail or malfunction at a certain rate. Please be sure to implement, at your own responsibilities, adequate safety measures including but not limited to fail-safe design against the physical injury, damage to any property, which a failure or malfunction of our Products may cause. The following are examples of safety measures:
 - Installation of protection circuits or other protective devices to improve system safety
 - Installation of redundant circuits to reduce the impact of single or multiple circuit failure
- Our Products are designed and manufactured for use under standard conditions and not under any special or extraordinary environments or conditions, as exemplified below. Accordingly, ROHM shall not be in any way responsible or liable for any damages, expenses or losses arising from the use of any ROHM's Products under any special or extraordinary environments or conditions. If you intend to use our Products under any special or extraordinary environments or conditions (as exemplified below), your independent verification and confirmation of product performance, reliability, etc. prior to use, must be necessary:
 - Use of our Products in any types of liquid, including water, oils, chemicals, and organic solvents
 - Use of our Products outdoors or in places where the Products are exposed to direct sunlight or dust
 - Use of our Products in places where the Products are exposed to sea wind or corrosive gases, including Cl₂, H₂S, NH₃, SO₂, and NO₂
 - Use of our Products in places where the Products are exposed to static electricity or electromagnetic waves
 - Use of our Products in proximity to heat-producing components, plastic cords, or other flammable items
 - Sealing or coating our Products with resin or other coating materials
 - Use of our Products without cleaning residue of flux (even if you use no-clean type fluxes, cleaning residue of flux is recommended); or Washing our Products by using water or water-soluble cleaning agents for cleaning residue after soldering
 - Use of the Products in places subject to dew condensation
- The Products are not subject to radiation-proof design.
- Please verify and confirm characteristics of the final or mounted products in using the Products.
- In particular, if a transient load (a large amount of load applied in a short period of time, such as pulse. is applied, confirmation of performance characteristics after on-board mounting is strongly recommended. Avoid applying power exceeding normal rated power; exceeding the power rating under steady-state loading condition may negatively affect product performance and reliability.
- De-rate Power Dissipation (Pd) depending on Ambient temperature (Ta). When used in sealed area, confirm the actual ambient temperature.
- Confirm that operation temperature is within the specified range described in the product specification.
- ROHM shall not be in any way responsible or liable for failure induced under deviant condition from what is defined in this document.

Precaution for Mounting / Circuit board design

- When a highly active halogenous (chlorine, bromine, etc.) flux is used, the residue of flux may negatively affect product performance and reliability.
- In principle, the reflow soldering method must be used; if flow soldering method is preferred, please consult with the ROHM representative in advance.

For details, please refer to ROHM Mounting specification

Precautions Regarding Application Examples and External Circuits

1. If change is made to the constant of an external circuit, please allow a sufficient margin considering variations of the characteristics of the Products and external components, including transient characteristics, as well as static characteristics.
2. You agree that application notes, reference designs, and associated data and information contained in this document are presented only as guidance for Products use. Therefore, in case you use such information, you are solely responsible for it and you must exercise your own independent verification and judgment in the use of such information contained in this document. ROHM shall not be in any way responsible or liable for any damages, expenses or losses incurred by you or third parties arising from the use of such information.

Precaution for Electrostatic

This Product is electrostatic sensitive product, which may be damaged due to electrostatic discharge. Please take proper caution in your manufacturing process and storage so that voltage exceeding the Products maximum rating will not be applied to Products. Please take special care under dry condition (e.g. Grounding of human body / equipment / solder iron, isolation from charged objects, setting of ionizer, friction prevention and temperature / humidity control).

Precaution for Storage / Transportation

1. Product performance and soldered connections may deteriorate if the Products are stored in the places where:
 - [a] the Products are exposed to sea winds or corrosive gases, including Cl₂, H₂S, NH₃, SO₂, and NO₂
 - [b] the temperature or humidity exceeds those recommended by ROHM
 - [c] the Products are exposed to direct sunshine or condensation
 - [d] the Products are exposed to high Electrostatic
2. Even under ROHM recommended storage condition, solderability of products out of recommended storage time period may be degraded. It is strongly recommended to confirm solderability before using Products of which storage time is exceeding the recommended storage time period.
3. Store / transport cartons in the correct direction, which is indicated on a carton with a symbol. Otherwise bent leads may occur due to excessive stress applied when dropping of a carton.
4. Use Products within the specified time after opening a humidity barrier bag. Baking is required before using Products of which storage time is exceeding the recommended storage time period.

Precaution for Product Label

QR code printed on ROHM Products label is for ROHM's internal use only.

Precaution for Disposition

When disposing Products please dispose them properly using an authorized industry waste company.

Precaution for Foreign Exchange and Foreign Trade act

Since our Products might fall under controlled goods prescribed by the applicable foreign exchange and foreign trade act, please consult with ROHM representative in case of export.

Precaution Regarding Intellectual Property Rights

1. All information and data including but not limited to application example contained in this document is for reference only. ROHM does not warrant that foregoing information or data will not infringe any intellectual property rights or any other rights of any third party regarding such information or data. ROHM shall not be in any way responsible or liable for infringement of any intellectual property rights or other damages arising from use of such information or data.:
2. No license, expressly or implied, is granted hereby under any intellectual property rights or other rights of ROHM or any third parties with respect to the information contained in this document.

Other Precaution

1. This document may not be reprinted or reproduced, in whole or in part, without prior written consent of ROHM.
2. The Products may not be disassembled, converted, modified, reproduced or otherwise changed without prior written consent of ROHM.
3. In no event shall you use in any way whatsoever the Products and the related technical information contained in the Products or this document for any military purposes, including but not limited to, the development of mass-destruction weapons.
4. The proper names of companies or products described in this document are trademarks or registered trademarks of ROHM, its affiliated companies or third parties.

General Precaution

1. Before you use our Products, you are requested to carefully read this document and fully understand its contents. ROHM shall not be in any way responsible or liable for failure, malfunction or accident arising from the use of any ROHM's Products against warning, caution or note contained in this document.
2. All information contained in this document is current as of the issuing date and subject to change without any prior notice. Before purchasing or using ROHM's Products, please confirm the latest information with a ROHM sales representative.
3. The information contained in this document is provided on an "as is" basis and ROHM does not warrant that all information contained in this document is accurate and/or error-free. ROHM shall not be in any way responsible or liable for any damages, expenses or losses incurred by you or third parties resulting from inaccuracy or errors of or concerning such information.

Mouser Electronics

Authorized Distributor

Click to View Pricing, Inventory, Delivery & Lifecycle Information:

[ROHM Semiconductor:](#)

[BD8628EFV-E2](#) [BD8624EFV-E2](#)