

EIA-Based Vector-Pak™ Subrack Systems



Subracks for EFP Modules

CMA Module Racks

These 19" Rackmount Subracks provide attractive, sturdy, and mechanically excellent housings to enclose electronic assemblies.

These units provide the benefits and features of custom enclosures without the expense.

EFP modules feature aluminum extruded sides to accept .062" thick P.C. cards. Extended front panels on modules allow thumb screw locking of module to subrack for easy insertion and extraction. The extended front panel also provides an attractive appearance.

Side panels fasten to sturdy Vector TSW model (1.75" wide) Struts with two screws. Subrack models accept widths of 1.6", 2.0" and 3.0" EFP modules; 4.5" module optional. Rear Struts are adjustable in width and height.

- 1.6", 2.0" and 3.0" evenly spaced modules are accepted
- Side Panels have double screw attachment to wide TSW (1.75") metal strut
- Rear Struts are adjustable in width and height with BR16-1 bracket
- Special aluminum extruded case guides and spacers provide secure mounting for modules.
- Standard 19" width. Other widths available by special order
- Filler panels available where mixing widths creates gaps
- Aluminum construction, brushed, with clear irridite finish
- Paint options available

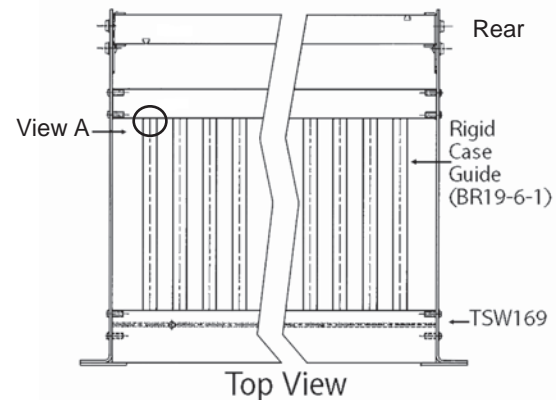
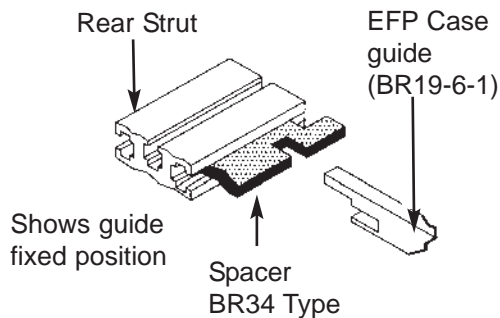

www.vectorelect.com

Subrack Part Number	# Of Modules	Width	Height	Depth
CMA13-16/90	10	19"	3U	9.00"
CMA13-20/90	8	19"	3U	9.00"
CMA13-30/90	5	19"	3U	9.00"
CMA14-16/90	10	19"	3U	12.00"
CMA14-20/90	8	19"	3U	12.00"
CMA14-30/90	5	19"	3U	12.00"
CMA15-20/90	8	19"	4U	12.00"

Subracks





EIA-Based Vector-Pak™ Subrack Systems

CMA Modules (EFPs)

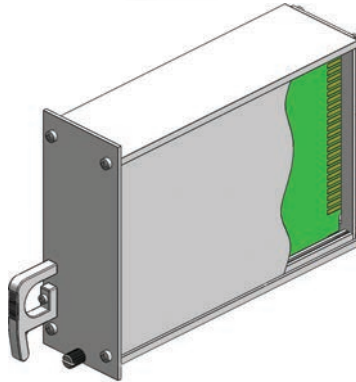

EFP204A66F - 2" EFP Modules with HA11 handle

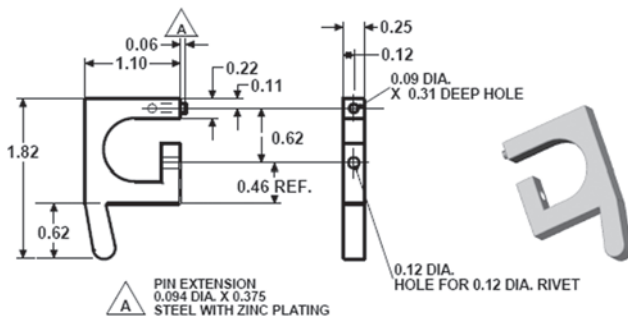

HA11 handle Pkg of 2,
order part number HA11/2

- Extended Front Panels provide thumb screw mounting and flush fit from module to module and with strut line.
- Modules provide shielding
- Front Panels may be customized with cutouts and/or color (Contact factory).
- All covers have locking detent; slides out of groove when released.
- Supplied in Kit form
- Modules with 6.5" depth accept 4.5" X 6.5" cards.
- Modules with 9.7" depth accept 4.5" X 9.6" cards.

Side Rail Extrusions: Grooves for card insertion

Side Rail Extrusions: Grooves for card insertion

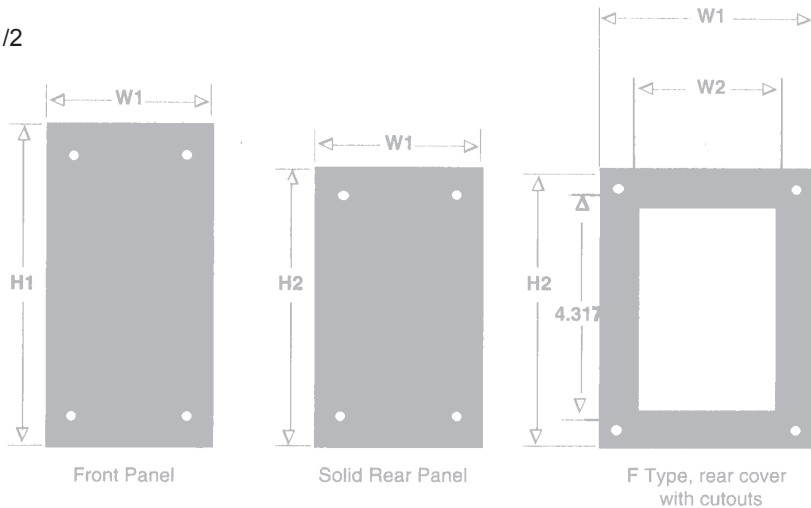
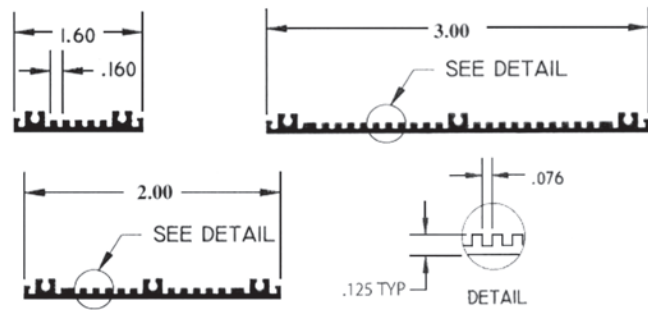

- Front panel is removable and may be customized
- HA11 finger-pull handle available separately (order part #HA11/2)
- Rear panels: single piece with cutouts (F type)
- Replacement side panels PL4566 (4.5" X 6.6") and PL4597 (4.5" X 9.7")

Kit Type Closed Rear Panel	Kit Type Open Rear Panel	L	W1	W2	H1	H2	Solid Front Panel #	Solid Rear Cover	Open Rear Panel
EFP164A66	EFP164A66F	6.5"	1.65"	1.31"	5.22"	4.62"	FP16A52	BP13-4	BP13-40F
EFP164A97	EFP164A97F	9.6"	1.65"	1.31"	5.22"	4.62"	FP16A52	BP13-4	BP13-40F
EFP204A66	EFP204A66F	6.5"	2.05"	1.71"	5.22"	4.62"	FP2A52	BP17-4	BP17-40F
EFP204A97	EFP204A97F	9.6"	2.05"	1.71"	5.22"	4.62"	FP2A52	BP17-4	BP17-40F
EFP304A66	EFP304A66F	6.5"	3.05"	2.71"	5.22"	4.62"	FP3A52	BP27-4	BP27-40F
EFP304A97	EFP304A97F	9.6"	3.05"	2.71"	5.22"	4.62"	FP3A52	BP27-4	BP27-40F
EFP454A66	EFP454A66F	6.5"	4.55"	4.21"	5.22"	4.62"	FP3A52	BP42-4	BP27-40F
EFP454A97	N/A	9.6"	4.55"	4.21"	5.22"	4.62"	FP45A52	BP42-4	BP42-40F
*EFP206A97	N/A	9.6"	2.05"	1.71"	6.97"	6.37"	FP2A70	BP17-6	N/A

* 4U for CMA15-20/90

INSTRUCTION FOR VECTORPAK™ Extended Front Panels (EFP) MODULES

1. Vectorpak™ EFP modules are available in various sizes and with either open frame-type or solid rear panels. Fig 2 illustrates both types and show that the solid rear panel can be machined or punched while the open frame-type allows for the PC board contacts to protrude.
2. PREPARATION OF MODULE PARTS prior to assembly should be as follows:
 - 2.1 Design front and rear panel layout
 - 2.2 Make connector/control cut-outs in addition to any ventilation holes needed in extruded top/bottom rails (side rails)
 - 2.3 Paint and/or silkscreen legend
 - 2.4 Attach mounting hardware, switches and indicators
3. CIRCUIT CARD PREPARATION: The maximum card dimensions are given in the EFP size tabulation at www.Vectorelect.com or in the Vector catalog. To enable the card to extend from the rear of the case, the normal card position is with the notch against the inside surface of the rear panel; card stops installed at the opposite end of the card will fix the card location within the module. The solid-type rear panel may be slotted, or the open frame-style may be used to mount the Vectorbord® Plugbord™. It is vital to lock the card into place with the CS0608-1 card stops included. The card stops supplied are pieces of threaded stock which are a press-fit into the card groove (see figure 4). Press-in with pliers or tap in with a small hammer in more accessible areas taking care to protect the clear anodized finish. If a variation of slot width due to manufacturing tolerances causes looseness, a more positive retention of card stops may be necessary. A short nail punch strike with a small hammer can be used to 'peen-over' or upset the grooved ridges on either side of the card stop. In order to prevent the card from tilting during installation and removal, card stops should be installed in both the top and bottom grooved rails. If there is insufficient space on the rails to place the card stops, a notch in the edge of the card may be necessary. A notch in the center of each card edge PCB would require only two card stops for containment in both directions.
4. ASSEMBLY: Where the Vector catalog part numbers of each part is given in the following, an asterisk (*) indicates the variation based on the particular EFP module kit purchased.
 - 4.1 Screw the back panel BP*.* to the chamfered end of the rails (P/N SR*.*.) using the no. 6-32 fillister head, self-tapping screws (P/N SC6-13)
 - 4.2 Slide the side covers (P/N PL*.*.) into position in the outside rails on either side of the grooves (see figs. 1 and 2) so that the smaller recessed detent (dimple) faces inward and locks against the rear panel. The detent (dimple) both holds the side cover in place and provides support for the back panel. Failure of detent to provide both functions can be remedied by slightly bending the side cover with hands and thumbs to provide needed adjustment.
 - 4.3 Install the PCB and any other components in the module. If card stops are used it may be necessary to spring the rails apart slightly towards the front to allow the card to ride over the stops and into place.
 - 4.4 Screw the front panel (P/N FP*.*.) to the other end of the rails using the 6-32 self-tapping miniature truss-head screws (P/N SC6-29)
 - 4.5 Remove the side covers to make internal connections from front or back panels to the PCB.
 - 4.6 Install the module retaining screw into the hole in the front panel; a jackscrew (P/N SC10-3A) is used to lever the module connector or PCB card-edge 'tongue' into the receptacle of the card-edge connector mounted on the CMA module subrack. As the jackscrew is being tightened, the PCB will insert and will 'Jack' the module assembly out of the CMA subrack as it is unscrewed. The jackscrew is held captive in the front panel with an 'E'-type retaining ring (P/N 0711-06-14) which should be pushed into the screw slot with a screwdriver or similar tool (see fig. 3A).
 - 4.7 If the side covers do not snap securely into position when replaced, they should be removed and the detent (dimple) area bowed inward slightly by hand; this should improve the retention action of the detent.
5. INSTALLATION: When installing the EFP module into the CMA module subrack, tighten the jackscrew to inject the module connector or PCB 'tongue' into the card-edge receptacle mounting on the subrack.

LIST OF PARTS INCLUDED WITH EACH EFP MODULE KIT

Part Number	Qty
SR** Extruded side rail (top/bottom holding PCB)	2
BP** Back Panel (eg. EFP164A66F = Frame-type open rear panel, EFP164A66 = solid rear panel)	1
FP** Front Panel	1
PL** Side covers with Detent (dimple)	2
IN198 Instruction sheet	

Each EFP module kit includes one **HD7-1** hardware pack that includes:

SC6-13, 6-32 Fillister head screws	4 or 6
SC-29, 6-32 Truss head screws	4
CS0608-1 Card Stop	8
SC10-3A jackscrew with 0711-06-14 E-type retaining ring	1

Figure 1 – Typical EFP Module

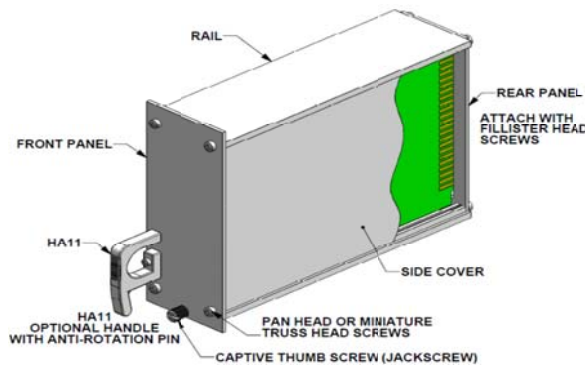

Jackscrew with 'E'-Retainer (Figure 3A)

HA11 Optional Handle

Figure 2

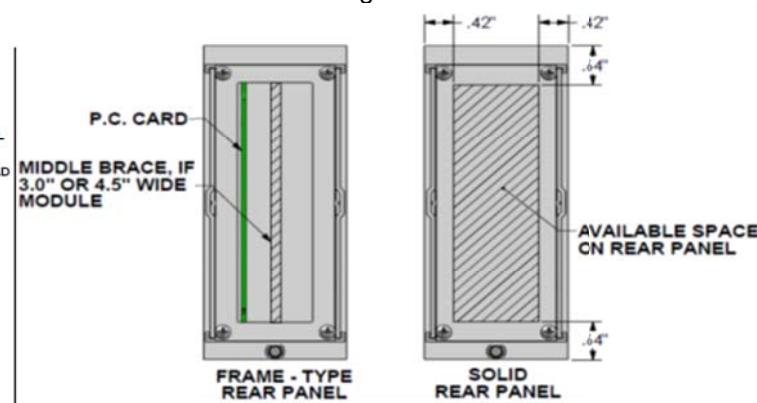
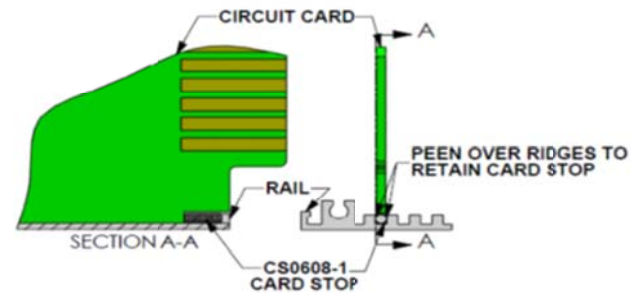

Figure 4



Mouser Electronics

Authorized Distributor

Click to View Pricing, Inventory, Delivery & Lifecycle Information:

[Vector:](#)

[CMA13-16/90](#) [CMA13-20/90](#) [EFP164A66F](#) [EFP204A66F](#) [EFP304A66F](#) [EFP304A97F](#) [EFP206A97](#) [EFP164A66](#)
[EFP454A97](#) [EFP204A66](#) [EFP204A97F](#) [EFP304A66](#) [EFP164A97](#) [CMA14-20/90](#) [CMA15-20/90](#) [EFP204A97](#)