

Date	SYM	REVISION RECORD	AUTH	DR.	CK.
11/30/12	C	DIM. 37.13 WAS 36.00 DIM. 17.32 WAS 17.04 DIM. Ø1.83 WAS Ø1.57	T.B.	B.S.	
12/05/14	D	UPDATED TO ROHS 2 COMPLIANT	T.B.	B.S.	

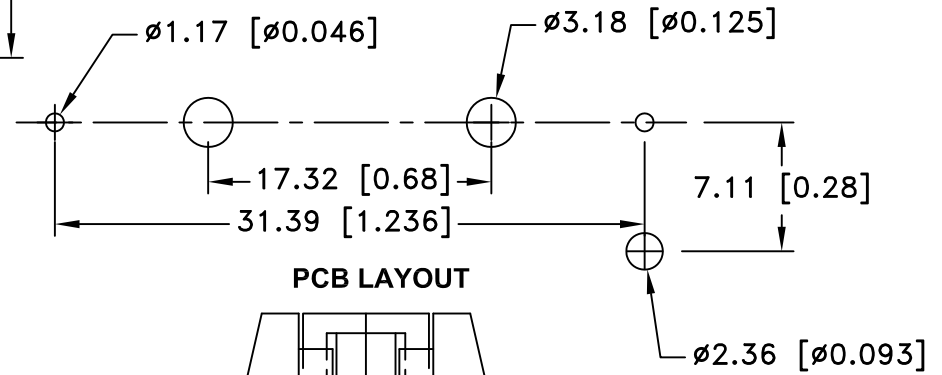

PCB LAYOUT

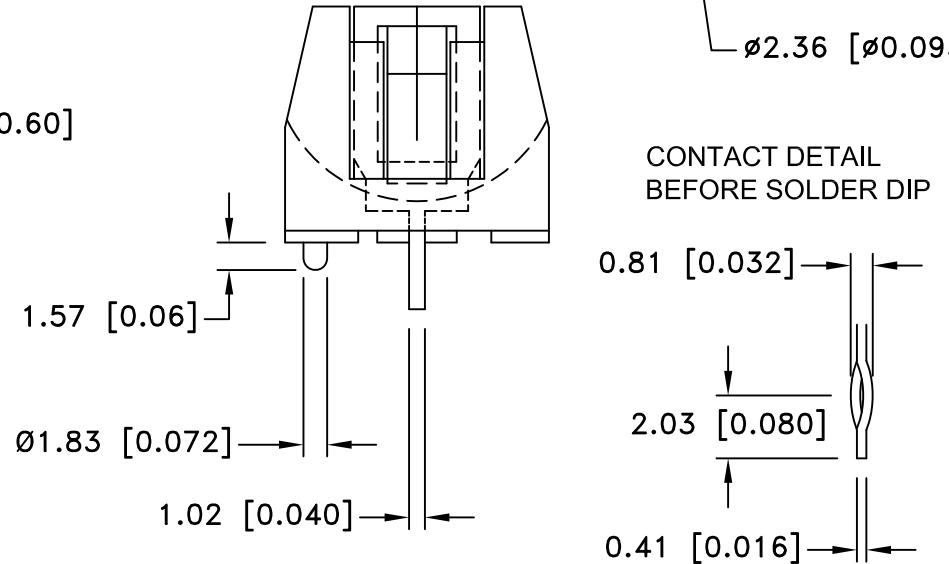
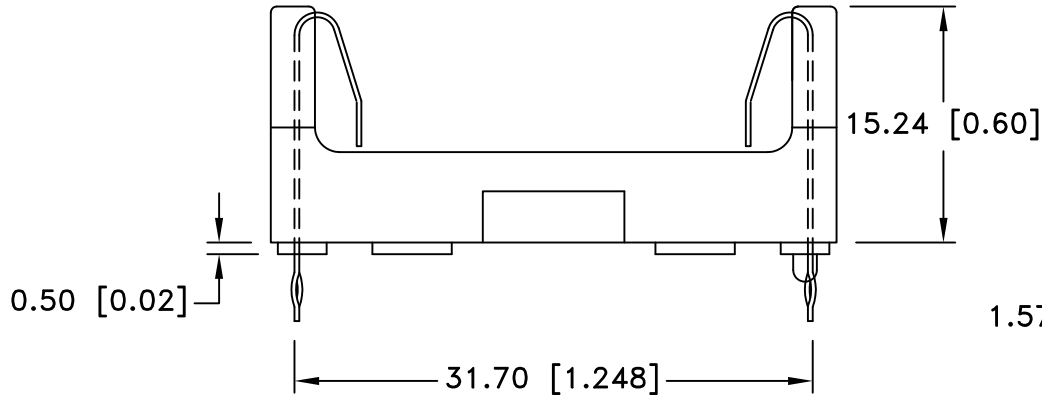

CONTACT DETAIL BEFORE SOLDER DIP

**SPECIFICATIONS:**

HOLDER MATERIAL: SELF EXTINGUISHING THERMOPLASTIC, BLACK PBT

FLAMMABILITY RATING:UL94V-0, FILE #E53829

CONTACTS: 302 SPRING TEMPER STAINLESS STEEL, NICKEL

PLATED OVERALL, SOLDER DIPPED PCB TAILS

DIELECTRIC STRENGTH: 560 VOLTS/MIL AT 25°C FOR 5 SEC.

TEMPERATURE RANGE: -55°C TO +180°C

RESISTANCE TO SOLVENTS: XYLENE, ETHYL , BUTYL, METHYL, PROPYL ALCOHOL, ETHYL ACETATE, HEPTANE, TOLUENE, REFRIGERANT

ROHS 2 COMPLIANT

**NOTES:**

EYELET STIMPSON STYLE#A1883 0.110" OD x 0.190" FLANGE  
FLANGE RECESS Ø0.203" x 0.090" DEEP  
ACCEPTS STANDARD 2-56 MACHINE SCREWS

Tolerance (Except as noted)	 <b>Memory Protection Devices, Inc</b> 200 Broad Hollow Road, Farmingdale, New York 11735	Scale	Drawn By B.S.
			Approved By T.B.
decimal ±.5 (.020)	Title CR2 BATTERY HOLDER, PCB MOUNTING		
Fractional ± .8 (.030)		Date 12/05/14	Drawing Number BH-CR2-PC
Angular ± 3°			