

Date	SYM	REVISION RECORD	AUTH	DR.	CK.
5/22/09	A	ADDED TEST RESULTS	T.B.	B.S.	
5/29/09	B	CONTACT MATERIAL WAS STAINLESS STEEL	T.B.	B.S.	
9/04/09	C	ADDED PIN LOCATION	T.B.	B.S.	
8/28/14	D	UPDATED TO ROHS 2 COMPLIANT	T.B.	B.S.	

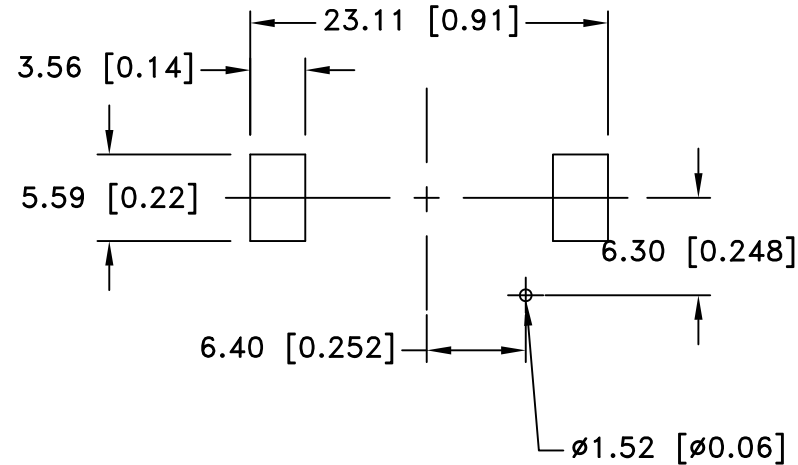
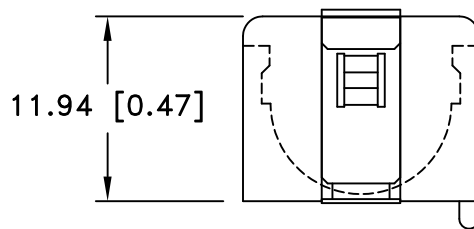
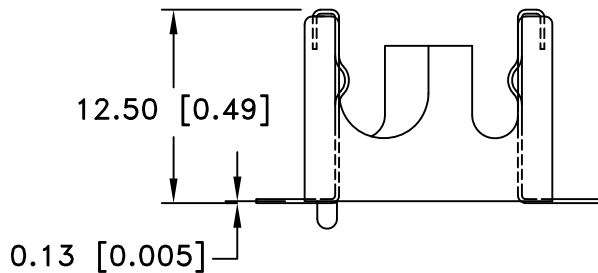
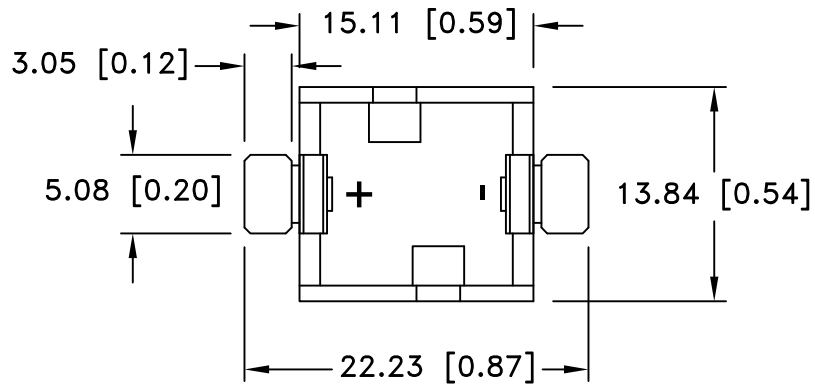

PCB LAYOUT

SPECIFICATIONS:

HOLDER MATERIAL: NYLON 46, 30% GLASS REINFORCED

FLAMMABILITY RATING:UL94-HB, FILE #E47960

CONTACTS: PHOSPHOR BRONZE, GOLD FLASH 1u -3u

TEMPERATURE RANGE: -40°C TO +270°C

* VIBRATION TEST: 10-50-10 HZ SWEEPED IN 60 SECONDS

X,Y,Z DIRECTION: 1 HOUR EACH DIRECTION

* RESULT: NO DISLODGE MENT OF THE CELL OR DAMAGE

NO DISCONTINUITY OVER 10 MICRO-SECONDS

* SHOCK TEST: HALF SINE WAVE ACCELERATION 150G, 6 MICRO-SECONDS

3 SHOCK PULSES EACH DIRECTION PER AXIS, TOTAL OF 18 PULSES

* RESULT: NO EVIDENCE OF PHYSICAL DAMAGE

* DROP TEST: DROPE D FROM 1M HIGH TO CONCRETE FLOOR

* RESULT: NO EVIDENCE OF PHYSICAL DAMAGE

ROHS 2 COMPLIANT

Tolerance (Except as noted)	 Memory Protection Devices, Inc 200 Broad Hollow Road, Farmingdale, New York 11735		
	decimal ±.5 (.020)	Scale	Drawn By B.S. Approved By T.B.
Fractional ± .8 (.030)	Title BC1/3N-C, CR1/3N LITHIUM BATTERY HOLDER		
Angular ± 3°	Date 8/28/14	Drawing Number BC1/3N-C-SM	