

Feb.1.2017 Copyright 2017 HIROSE ELECTRIC CO., LTD. All Rights Reserved.

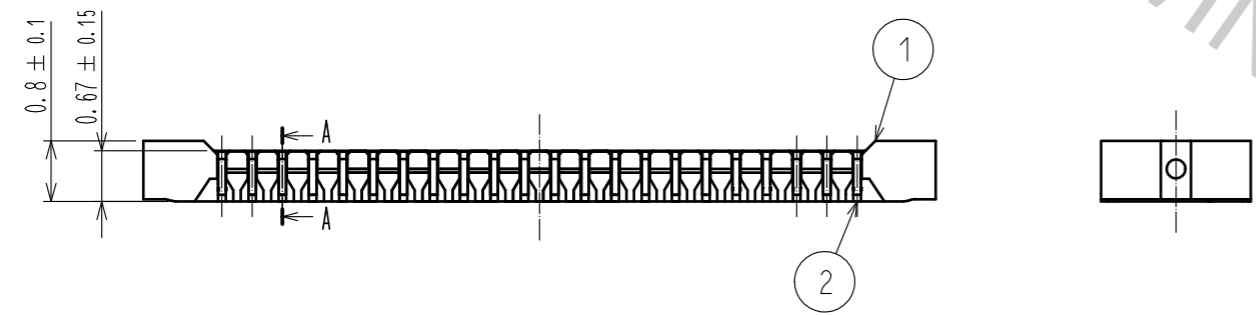

A-A (50:1)

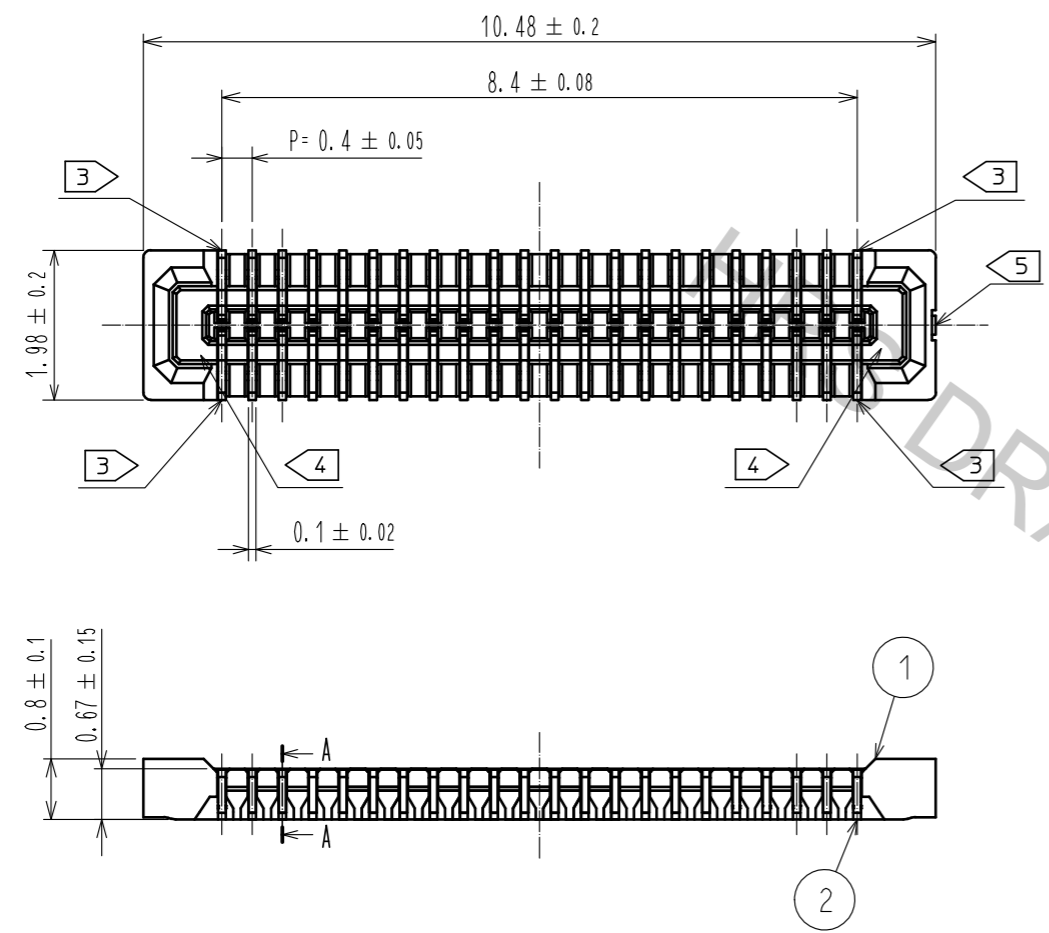
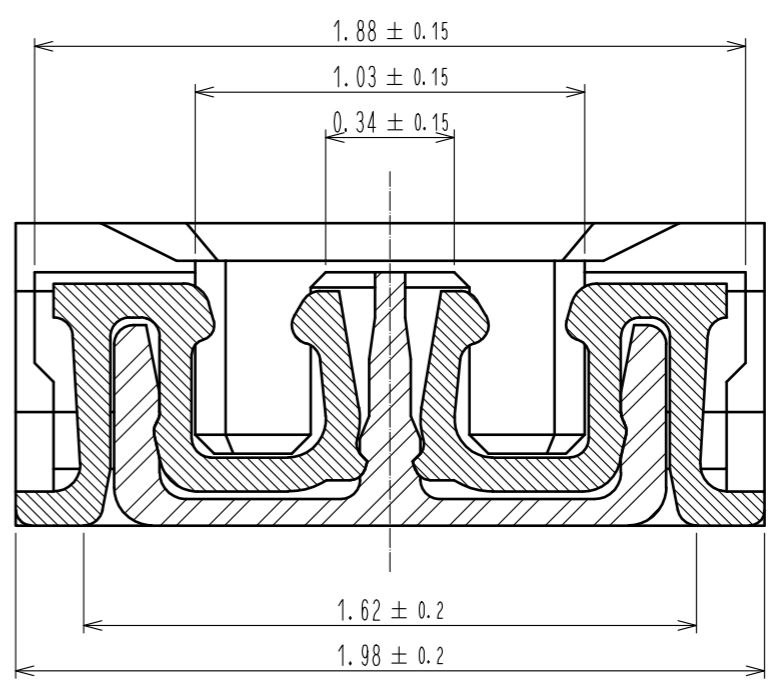

ENGAGEMENT FIGURE (50:1)

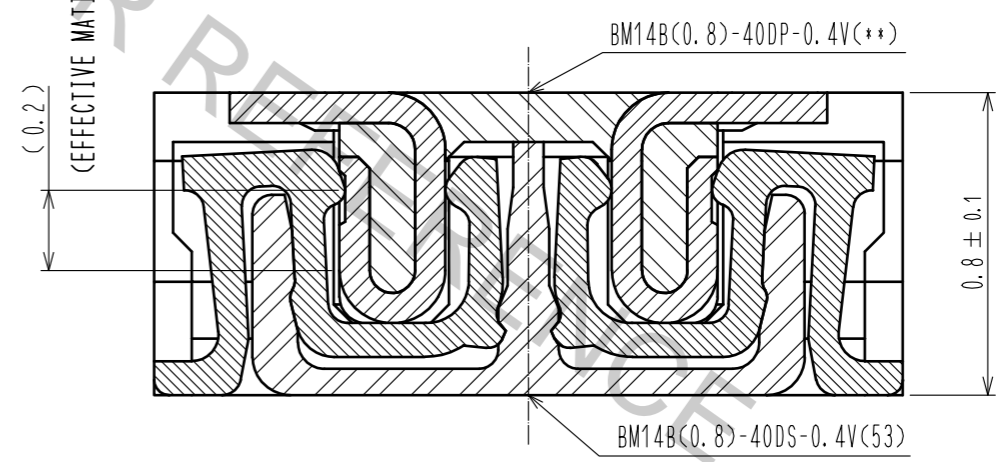

- NOTE) 1. ALL LEAD CO-PLANARITY SHALL BE 0.08mm MAX
 2. CONTACT PLATING SPECIFICATIONS.
 CONTACT AREA : GOLD 0.05 μm MIN
 SMT LEAD : GOLD 0.05 μm MIN
 UNDERPLATING : NICKEL 1 μm MIN
 (SURFACE : SEALING)
 3. EACH CONTACTS AT 4 CORNERS ARE PROVIDED FOR METAL FITTINGS AND GROUNDING PURPOSE.
 4. HRS MARK AND CAV NO. ARE INDICATED IN APPROX POSITION SHOWN.
 5. GATE POSITION IS INDICATED IN APPROX POSITION SHOWN.

3	PS	CLEAR (ENBOSSED CARRIER TAPE)	6	PS	CLEAR (REINFORCEMENT COLLAR)			
2	PHOSPHOR BRONZE	2	5	PS	BLACK (PLASTIC REEL)			
1	LCP	UL94 V-0, BLACK	4	POLYESTER	CLEAR (COVER TAPE)			
NO.	MATERIAL	FINISH . REMARKS	NO.	MATERIAL	FINISH . REMARKS			
UNITS	mm	SCALE	10:1	COUNT	DESCRIPTION OF REVISIONS	DESIGNED	CHECKED	DATE
HIROSE ELECTRIC CO., LTD.		APPROVED : MO. ISHIDA	17.01.19	DRAWING NO. EDC-319843-53-00				
		CHECKED : TS. MIYAZAKI	17.01.19	PART NO. BM14B(0.8)-40DS-0.4V(53)				
		DESIGNED : NY. YAMASHIRO	17.01.19	CODE NO. CL684-8008-9-53				
		DRAWN : SN. NUMAZAKI	17.01.18					

Feb.1.2017 Copyright 2017 HIROSE ELECTRIC CO., LTD. All Rights Reserved.

◆ RECOMMENDED PCB LAYOUT

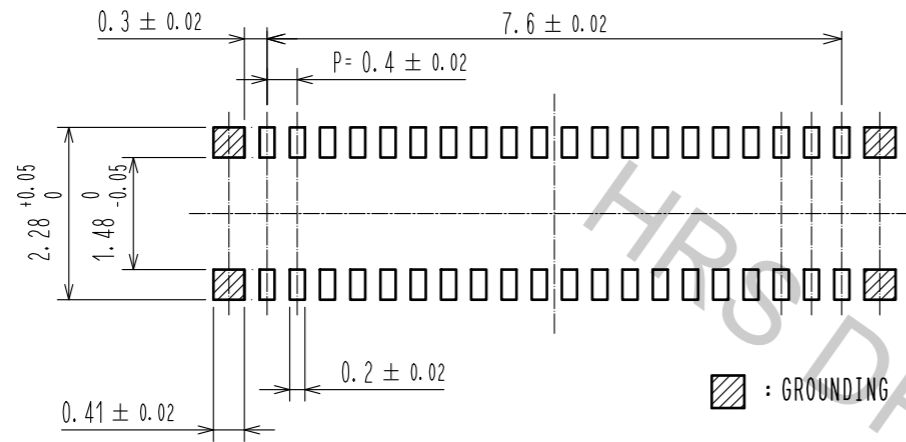

◆ RECOMMENDED METAL MASK DIMENSIONS

METAL MASK THICKNESS : 100 μm

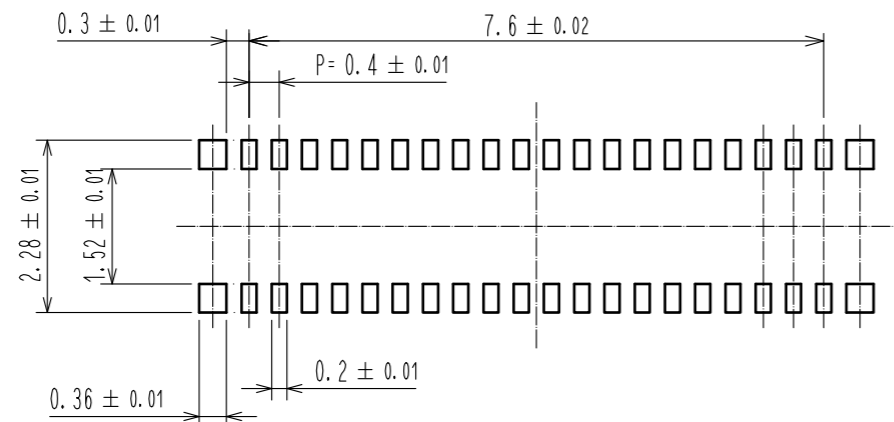

⑥ RECOMMENDED REFLOW TEMPERATURE PROFILE USING LEAD-FREE SOLDER PASTE.

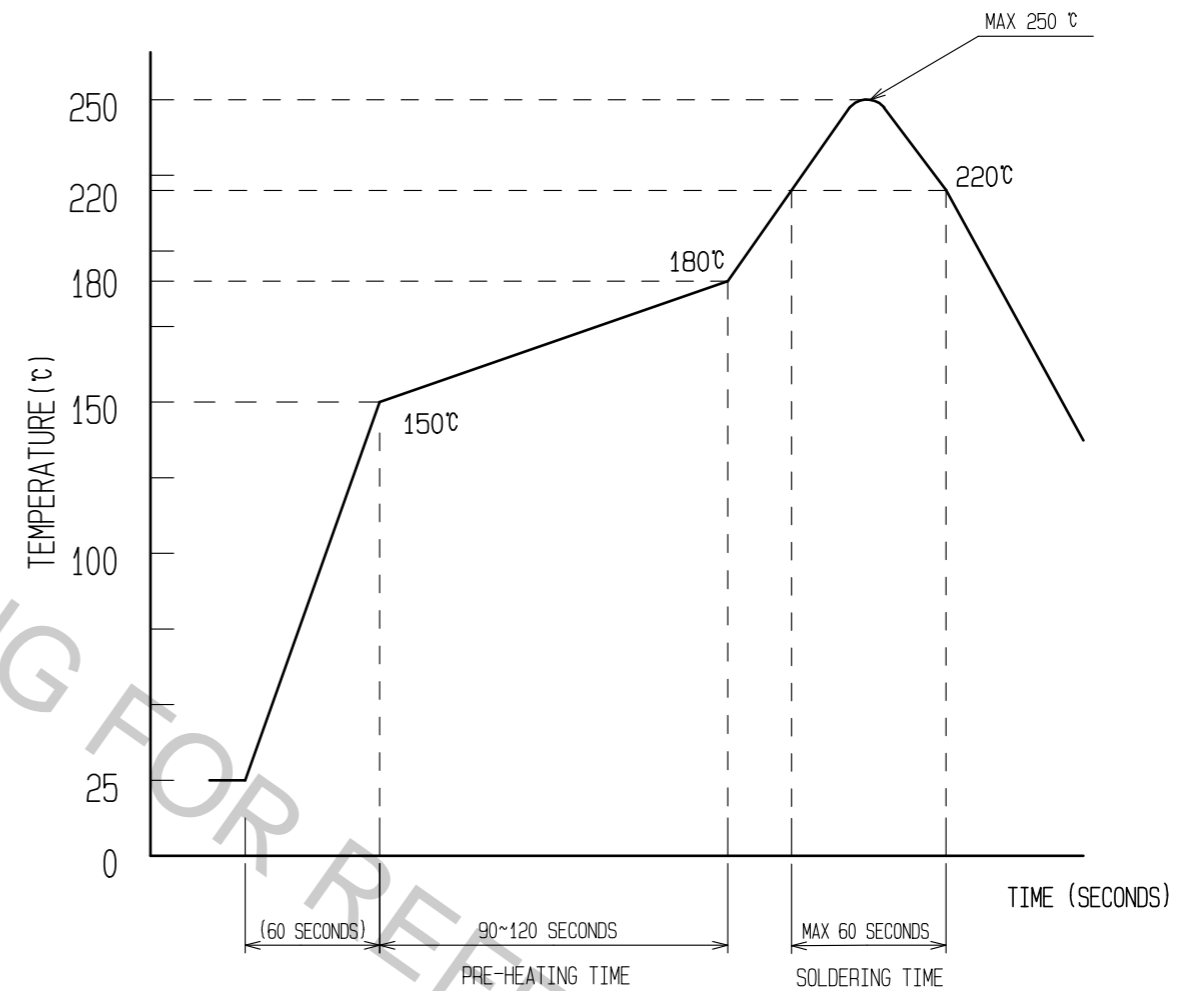

- REFLOW METHOD: IR REFLOW.
 NUMBER OF REFLOW CYCLES: 2 CYCLES MAX.
- REFLOW TIME
 DURATION ABOVE 220°C, 60 SEC. MAX.
 (PEAK TEMPERATURE: 250°C MAX)
 - PRE-HEAT TIME
 PRE-HEAT TEMPERATURE(MIN): 150°C
 PRE-HEAT TEMPERATURE(MAX): 180°C
 PRE-HEAT TIME: 90-120 sec.

⑥ THIS TEMPERATURE PROFILE IS PER THE CONDITIONS SHOWN ABOVE. ADDITIONAL FACTORS, SUCH AS SOLDER PASTE TYPE, PCB SIZE AND OTHER MOUNTED COMPONENTS COULD AFFECT THE PROFILE, THEREFORE, A THOROUGH EVALUATION OF MOUNTING CONDITION IS REQUIRED PRIOR TO PRODUCTION. TEMPERATURE IS MEASURED AT CONTACT LEAD.

HRS	DRAWING NO.	EDC-319843-53-00
	PART NO.	BM14B(0.8)-40DS-0.4V(53)
	CODE NO.	CL684-8008-9-53

EMBOSSED CARRIER TAPE PACKAGING (5:1)

STYLE AND DIMENTION OF REEL (FREE)

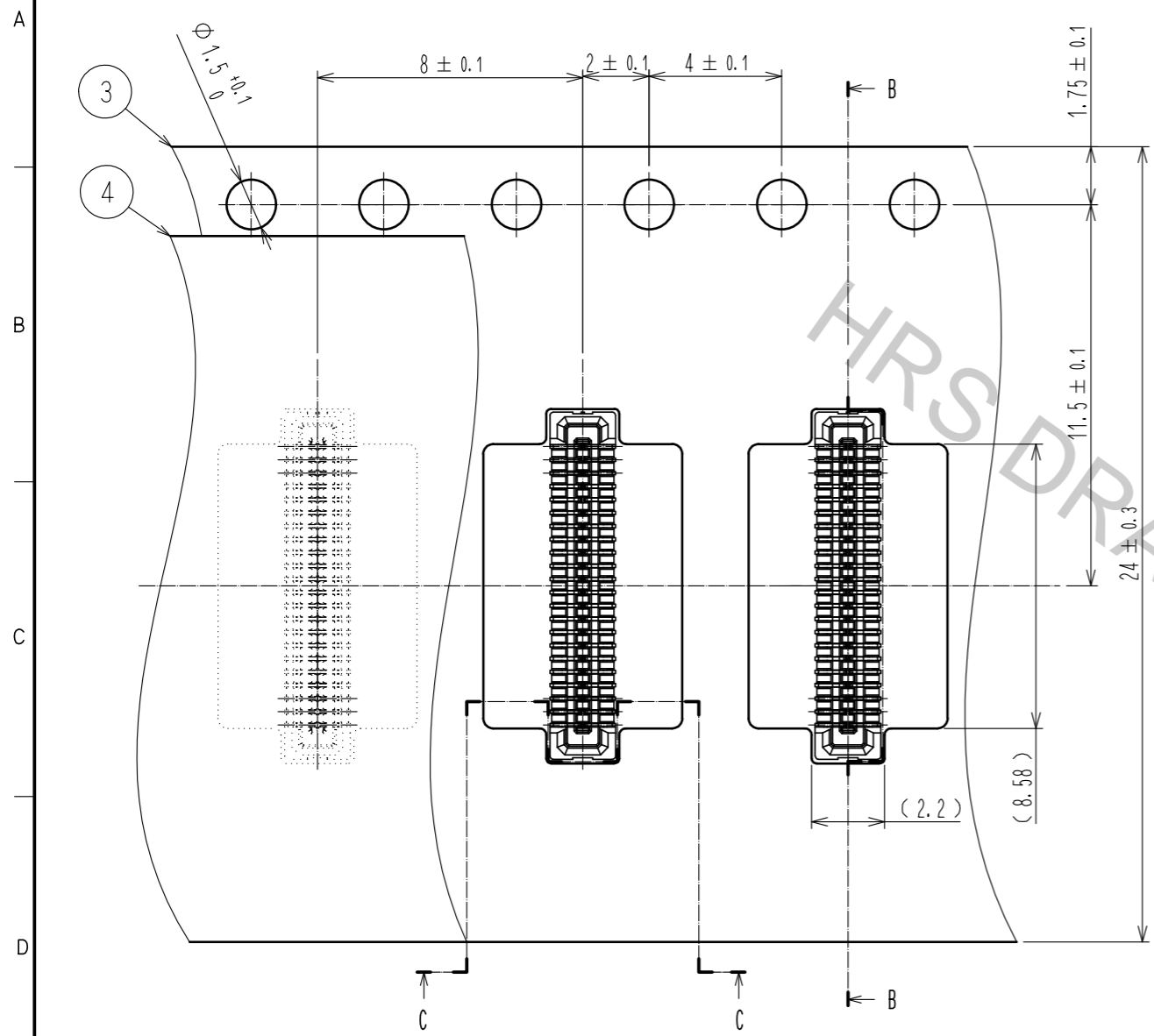

B-B (5:1)

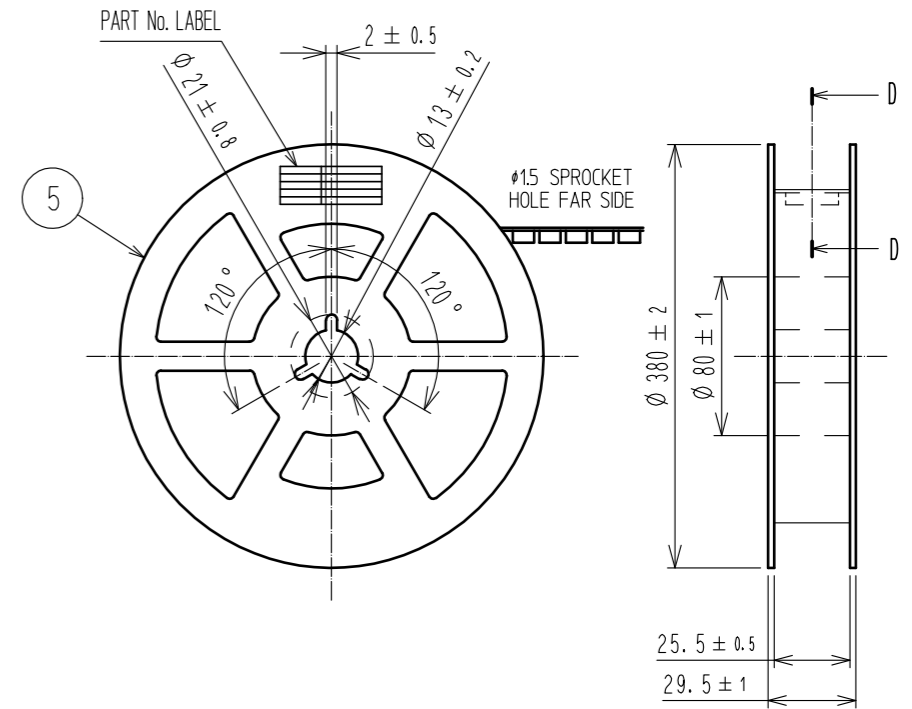
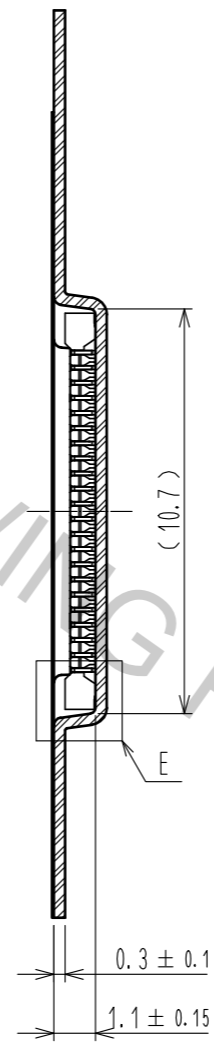

DETAIL OF PART No. LABEL

製造年月日	** ** *	DATE OF MANUFACTURED
製品コード	CL684-8008-9-53	CODE No.
製品名	BM14B<0.8>-40DS-0.4V<53>	PART No.
数量	1,000	QUANTITY
納入者	ヒロセ電機(株)	SUPPLIER

DATE OF MANUFACTURED
CODE No.
PART No.
QUANTITY
SUPPLIER

E<10:1>

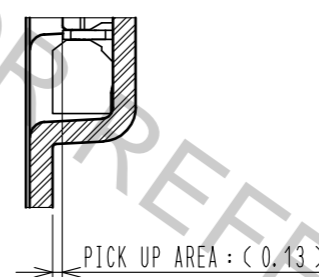

C-C (5:1)

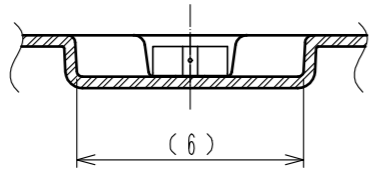

DIRECTION OF UNREELING

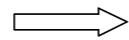

D-D (FREE)

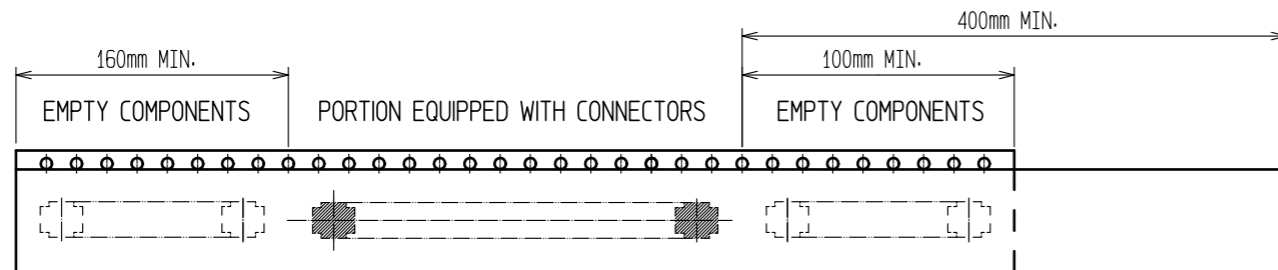
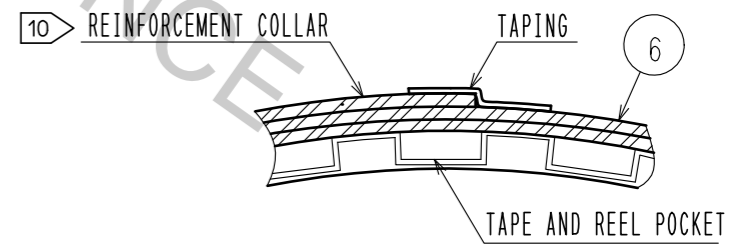

7. PER REEL 1000 CONNECTORS.

8. THE DIMENSIONS IN PARENTHESES ARE FOR REFERENCE.

9 REFER TO JIS C 0806(PACKAGING OF COMPONENTS FOR AUTOMATIC HANDLING)

10 AFTER PACKAGING, ROLL 2 METERS OF THE REINFORCEMENT COLLAR TO OUTER CIRCUMFERENCE OF TAPE AND REEL POCKET, AND TAPE DOWN AT THE END THE COLLAR.

HRS	DRAWING NO.	EDC-319843-53-00
	PART NO.	BM14B<0.8>-40DS-0.4V<53>
	CODE NO.	CL684-8008-9-53
		\triangle 3/3