

Common Mode Chokes – BU Series

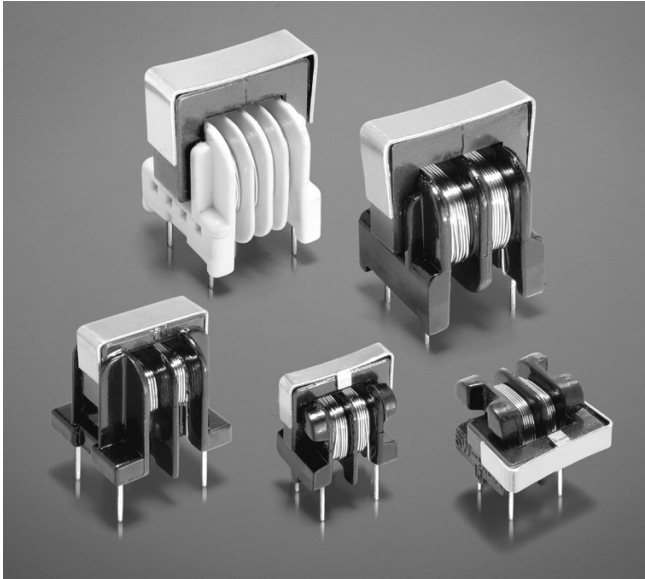

These low cost, high performance choke coils are designed to virtually eliminate line conducted common mode noise.

The BU9S and BU9HS families are ideal for signal line applications; the others can be used in switching power supplies and power supply circuits. All provide significant attenuation of common mode noise across a broad range of frequencies.

For height-restricted applications, the BU9 and BU9S filters are available in a horizontal configuration, which reduces their height to under half an inch (12.5 mm).

For free evaluation samples, contact Coilcraft or request them on-line at www.coilcraft.com.

Core material Ferrite

Terminations RoHS compliant tin-silver over copper. Other terminations available at additional cost.

Weight BU9: 3.1 – 4.1 g
 BU9H: 3.1 – 4.1 g
 BU9HS: 3.1 – 3.8 g
 BU9S: 3.1 – 3.8 g
 BU10: 6.3 – 6.9 g
 BU15: 14.6 – 16.1 g
 BU16: 15.1 – 18.0 g

Ambient temperature –40°C to +125°C

Storage temperature Component: –40°C to +125°C.

Tray packaging: –40°C to +80°C

Moisture Sensitivity Level (MSL) 1 (unlimited floor life at <30°C / 85% relative humidity)

Failures in Time (FIT) / Mean Time Between Failures (MTBF)

38 per billion hours / 26,315,789 hours, calculated per Telcordia SR-332

Packaging BU9: 100 per tray
 BU9H: 100 per tray
 BU9HS: 100 per tray
 BU9S: 100 per tray
 BU10: 100 per tray
 BU15: 80 per tray
 BU16: 80 per tray

PCB washing Tested with pure water or alcohol only. For other solvents, see Doc787_PCB_Washing.pdf.



www.coilcraft.com

US +1-847-639-6400 sales@coilcraft.com
UK +44-1236-730595 sales@coilcraft-europe.com
Taiwan +886-2-2264 3646 sales@coilcraft.com.tw
China +86-21-6218 8074 sales@coilcraft.com.cn
Singapore + 65-6484 8412 sales@coilcraft.com.sg

Document 260-1 Revised 08/06/13

© Coilcraft Inc. 2013

This product may not be used in medical or high risk applications without prior Coilcraft approval. Specification subject to change without notice. Please check web site for latest information.



Common Mode Chokes - BU9, BU9H Series

Part number	Impedance max (kOhms)	Frequency range @ 75% of impedance max	DCR ¹ (Ohms)	Current max (Aac)	Inductance ² L1, L2 min (mH)	Inductance difference L1 - L2 max (µH)
BU9-103R25BL	60 @ 220 kHz	200–240 kHz	3.5	0.25	10.0	200
BU9-2820R5BL	53 @ 410 kHz	310–430 kHz	1.0	0.50	2.8	50
BU9-1320R7BL	52 @ 660 kHz	600–700 kHz	0.5	0.70	1.3	50
BU9-6011R0BL	36 @ 1300 kHz	1200–1400 kHz	0.2	1.00	0.6	25
BU9-2011R6BL	5.4 @ 1500 kHz	900–2100 kHz	0.1	1.60	0.2	25
BU9H-103R25BL	60 @ 220 kHz	200–240 kHz	3.5	0.25	10.0	200
BU9H-2820R5BL	53 @ 410 kHz	310–430 kHz	1.0	0.50	2.8	50
BU9H-1320R7BL	52 @ 660 kHz	600–700 kHz	0.5	0.70	1.3	50
BU9H-6011R0BL	36 @ 1300 kHz	1200–1400 kHz	0.2	1.00	0.6	25
BU9H-2011R6BL	5.4 @ 1500 kHz	900–2100 kHz	0.1	1.60	0.2	25

1. DCR is per winding
2. Inductance tested at 1 kHz, 1 Vrms, 0 Adc on an Agilent/HP 4284A LCR-meter or equivalent.
3. 1000 Vrms typical isolation between windings.
4. Electrical specifications at 25°C.

Typical Attenuation

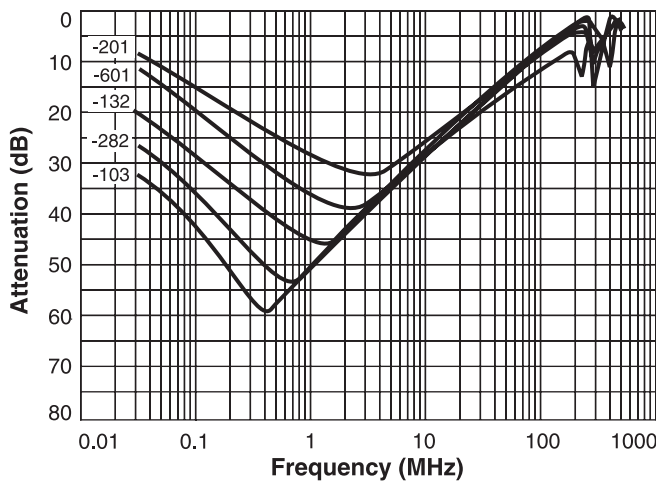

Typical Impedance

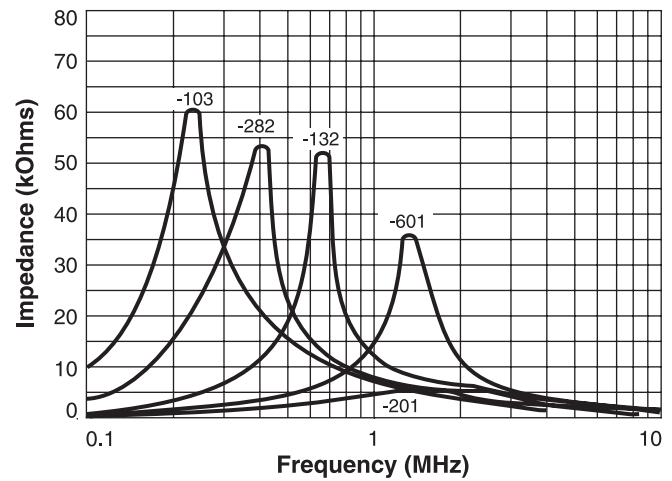

BU9

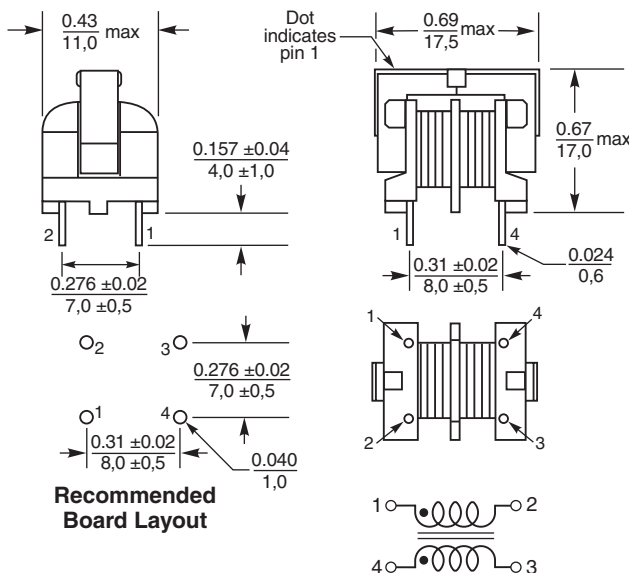

BU9H

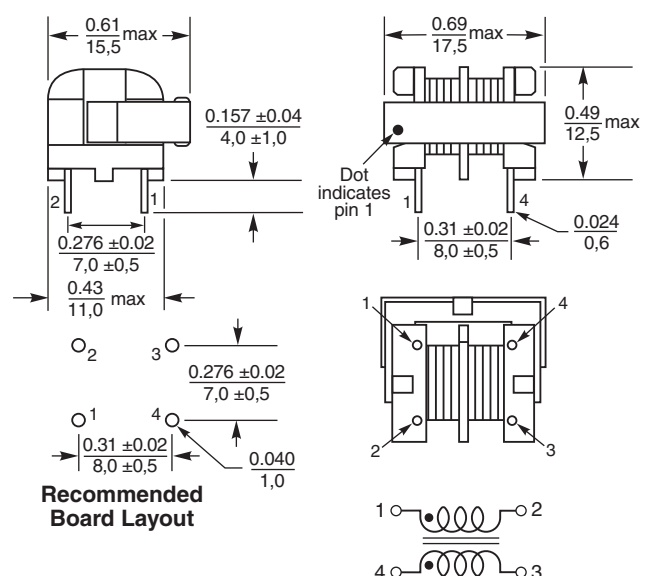

US +1-847-639-6400 sales@coilcraft.com
UK +44-1236-730595 sales@coilcraft-europe.com
Taiwan +886-2-2264 3646 sales@coilcraft.com.tw
China +86-21-6218 8074 sales@coilcraft.com.cn
Singapore +65-6484 8412 sales@coilcraft.com.sg

Document 260-2 Revised 08/06/13
 © Coilcraft Inc. 2013
 This product may not be used in medical or high risk applications without prior Coilcraft approval. Specification subject to change without notice. Please check web site for latest information.



Common Mode Chokes - BU9S, BU9HS Series

Part number	Impedance max (kOhms)	Frequency range @ 75% of impedance max	DCR ¹ (Ohms)	Current max (Aac)	Inductance ² L1, L2 min (mH)	Inductance difference L1 - L2 max (µH)
BU9S-153R15BL	71 @ 210 kHz	190–230 kHz	5.0	0.15	15.0	300
BU9S-7020R3BL	66 @ 330 kHz	300–360 kHz	2.5	0.30	7.0	200
BU9HS-153R15BL	71 @ 210 kHz	190–230 kHz	5.0	0.15	15.0	300
BU9HS-7020R3BL	66 @ 330 kHz	300–360 kHz	2.5	0.30	7.0	200

1. DCR is per winding
2. Inductance tested at 1 kHz, 1 Vrms, 0 Adc on an Agilent/HP 4284A LCR-meter or equivalent.
3. 1000 Vrms typical isolation between windings.
4. Electrical specifications at 25°C.

Typical Attenuation

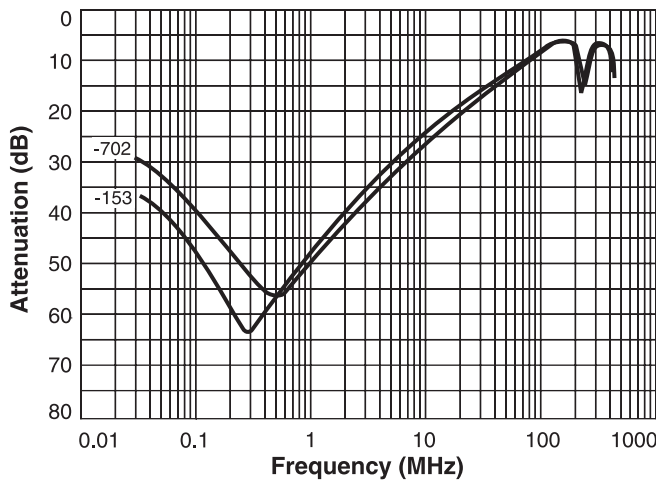

Typical Impedance

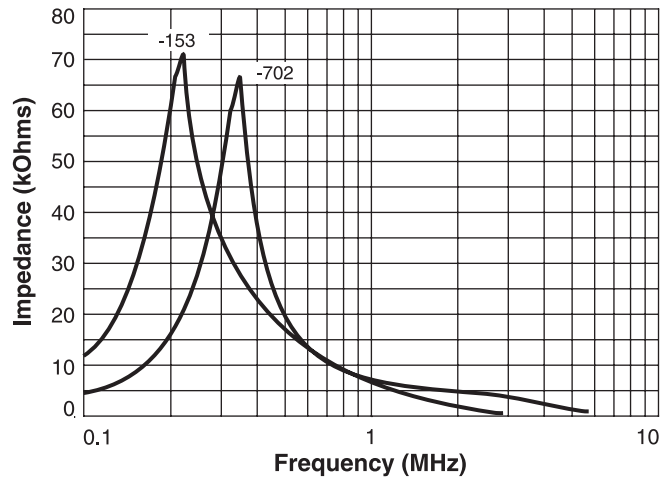

BU9S

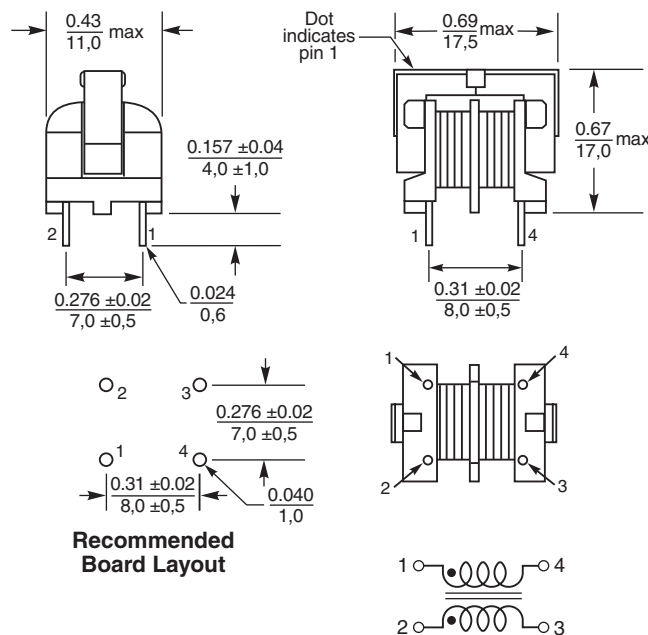

BU9HS

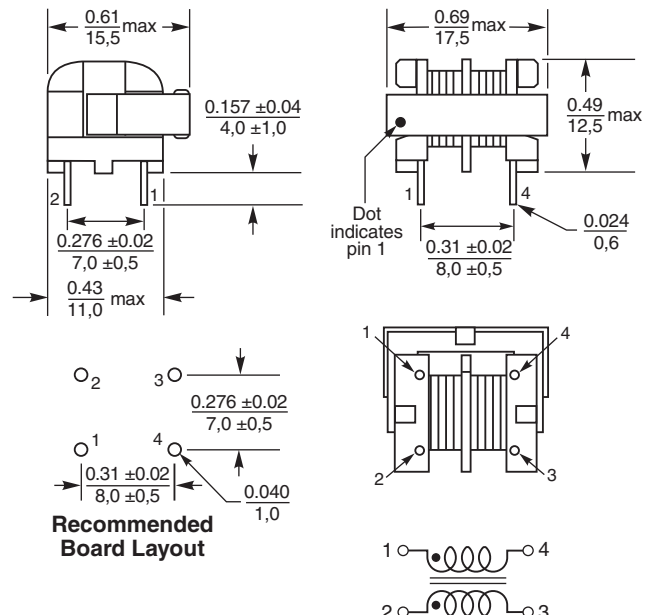

US +1-847-639-6400 sales@coilcraft.com
UK +44-1236-730595 sales@coilcraft-europe.com
Taiwan +886-2-2264 3646 sales@coilcraft.com.tw
China +86-21-6218 8074 sales@coilcraft.com.cn
Singapore + 65-6484 8412 sales@coilcraft.com.sg

Document 260-3 Revised 08/06/13
 © Coilcraft Inc. 2013
 This product may not be used in medical or high risk applications without prior Coilcraft approval. Specification subject to change without notice. Please check web site for latest information.



Common Mode Chokes - BU10 Series

Part number	Impedance max (kOhms)	Frequency range @ 75% of impedance max	DCR ¹ (Ohms)	Current max (Aac)	Inductance ² L1, L2 min (mH)	Inductance difference L1 - L2 max (µH)
BU10-1811R2BL	3.9 @ 1.8 MHz	1000–3200 kHz	0.20	1.20	0.18	30
BU10-1311R6BL	2.2 @ 2.2 MHz	800–2000 kHz	0.12	1.60	0.13	20
BU10-1012R2BL	1.6 @ 3.1 MHz	1300–8900 kHz	0.08	2.20	0.10	15
BU10-6003R0BL	1.0 @ 3.0 MHz	800–10000 kHz	0.04	3.00	0.06	10

1. DCR is per winding
2. Inductance tested at 1 kHz, 1 Vrms, 0 Adc on an Agilent/HP 4284A LCR-meter or equivalent.
3. 1000 Vrms typical isolation between windings.
4. Electrical specifications at 25°C.

Typical Attenuation

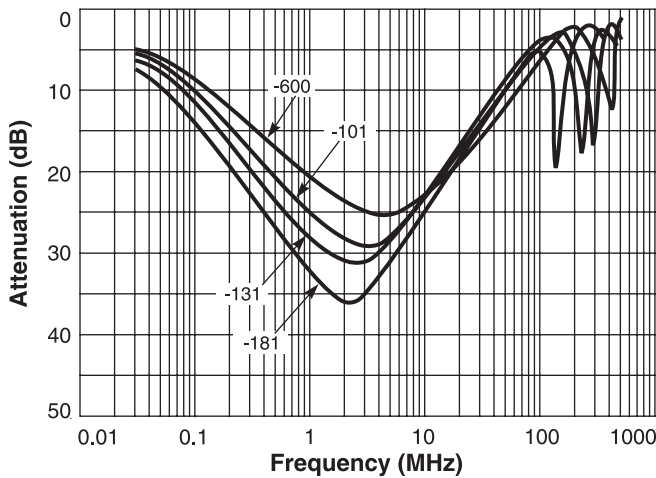

Typical Impedance

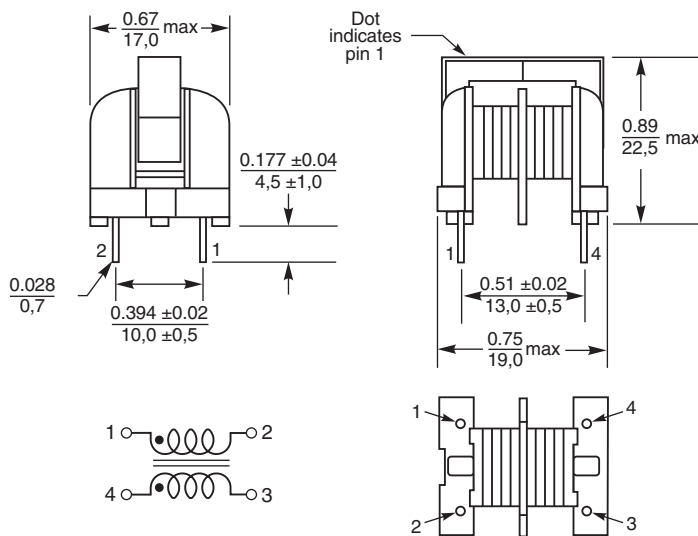
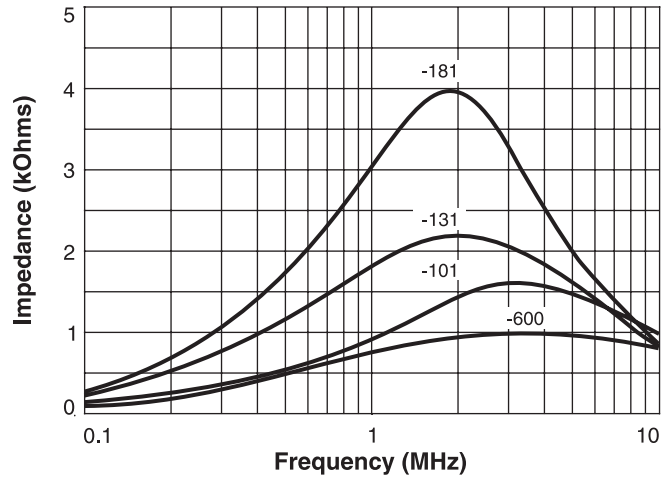

Recommended Board Layout

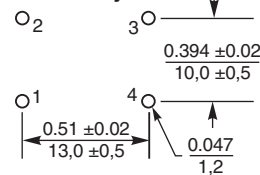

US +1-847-639-6400 sales@coilcraft.com
UK +44-1236-730595 sales@coilcraft-europe.com
Taiwan +886-2-2264 3646 sales@coilcraft.com.tw
China +86-21-6218 8074 sales@coilcraft.com.cn
Singapore + 65-6484 8412 sales@coilcraft.com.sg

Document 260-4 Revised 08/06/13

© Coilcraft Inc. 2013

This product may not be used in medical or high risk applications without prior Coilcraft approval. Specification subject to change without notice. Please check web site for latest information.



Common Mode Chokes - BU15 Series

Part number	Impedance max (kOhms)	Frequency range @ 75% of impedance max	DCR ¹ (Ohms)	Current max (Aac)	Inductance ² L1, L2 min (mH)	Inductance difference L1 - L2 max (µH)
BU15-4530R4BL	400 @ 230 kHz	140 – 160 kHz	3.0	0.40	45.0	300
BU15-1430R7BL	115 @ 470 kHz	400 – 650 kHz	1.0	0.70	14.0	300
BU15-7521R0BL	60 @ 600 kHz	420 – 720 kHz	0.6	1.00	7.5	150
BU15-4421R3BL	36 @ 670 kHz	430 – 1000 kHz	0.3	1.30	4.4	100
BU15-2721R6BL	20 @ 1000 kHz	510 – 1400 kHz	0.2	1.60	2.7	60

1. DCR is per winding
2. Inductance tested at 1 kHz, 1 Vrms, 0 Adc on an Agilent/HP 4284A LCR-meter or equivalent.
3. 1000 Vrms typical isolation between windings.
4. Electrical specifications at 25°C.

Typical Attenuation

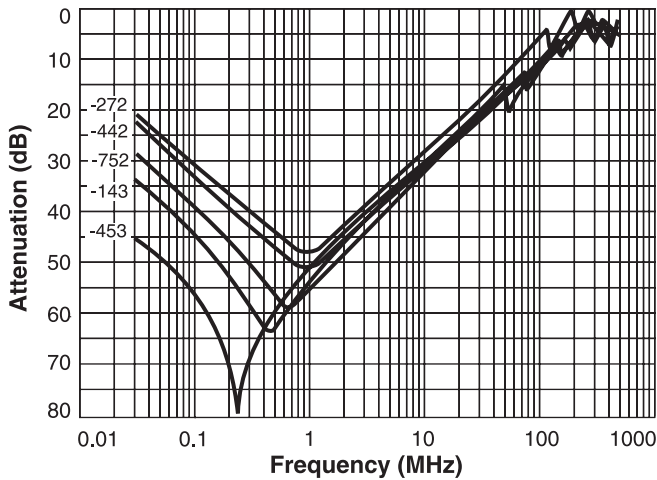

Typical Impedance

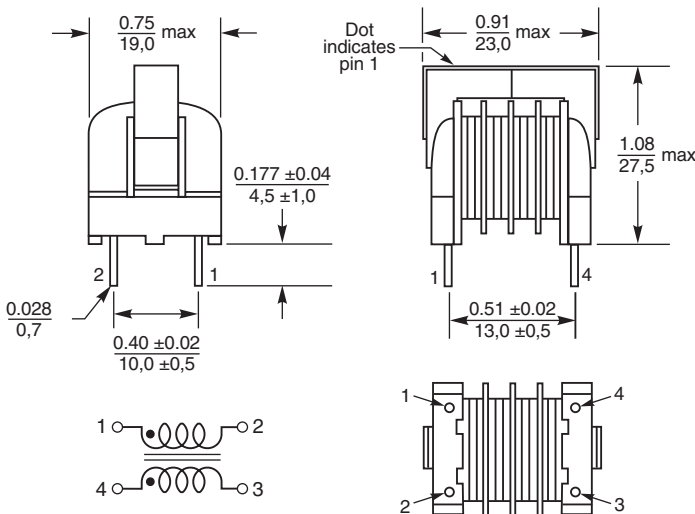
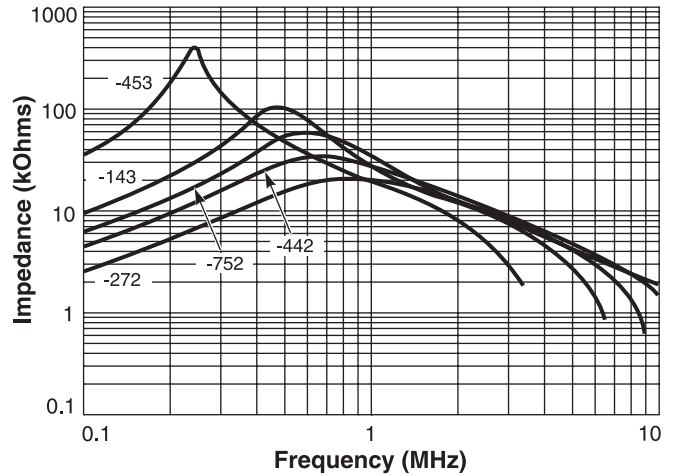

Recommended Board Layout

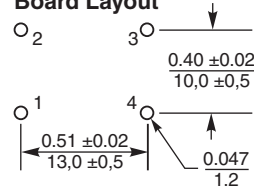



Common Mode Chokes - BU16 Series

Part number	Impedance max (kOhms)	Frequency range @ 75% of impedance max	DCR ¹ (Ohms)	Current max (Aac)	Inductance ² L1, L2 min (mH)	Inductance difference L1 - L2 max (µH)
BU16-4530R5BL	285 @ 150 kHz	140 – 160 kHz	2.3	0.50	45.0	900
BU16-2530R7BL	120 @ 200 kHz	160 – 220 kHz	1.3	0.70	25.0	500
BU16-1031R0BL	60 @ 320 kHz	260 – 390 kHz	0.5	1.00	10.0	200
BU16-4021R5BL	20 @ 470 kHz	360 – 600 kHz	0.3	1.50	4.0	80
BU16-2022R0BL	11 @ 690 kHz	450 – 900 kHz	0.2	2.00	2.0	50

1. DCR is per winding
2. Inductance tested at 1 kHz, 1 Vrms, 0 Adc on an Agilent/HP 4284A LCR-meter or equivalent.
3. 1000 Vrms typical isolation between windings.
4. Electrical specifications at 25°C.

Typical Attenuation

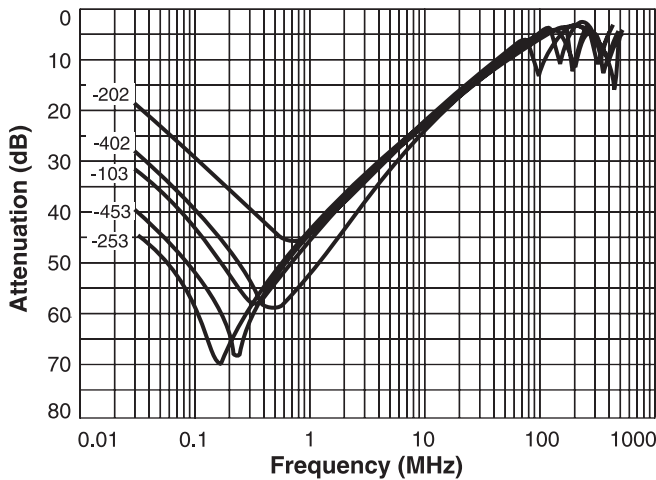

Typical Impedance

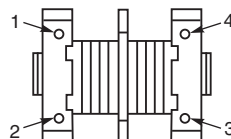
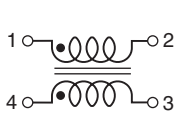
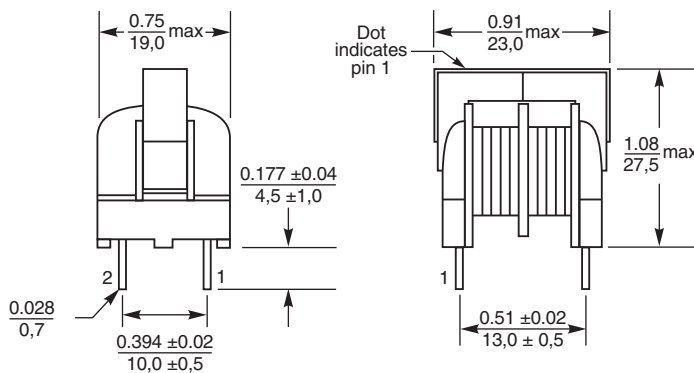
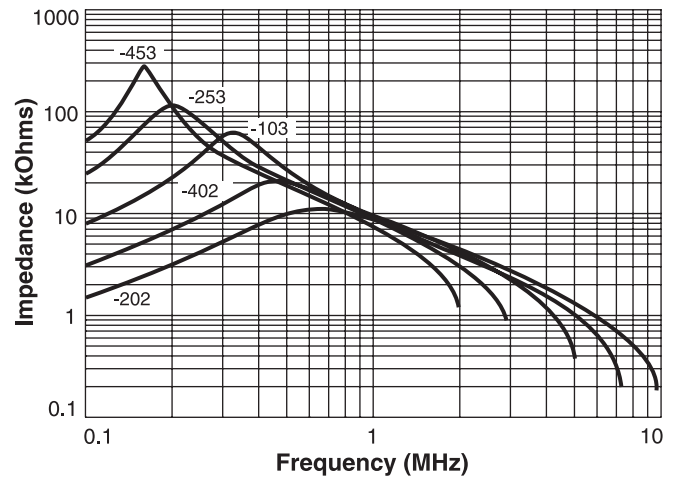

Recommended Board Layout

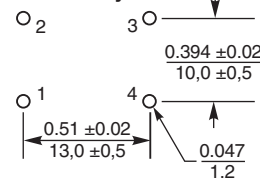

Mouser Electronics

Authorized Distributor

Click to View Pricing, Inventory, Delivery & Lifecycle Information:

Coilcraft:

[BU9HS-153R15BL](#) [BU9-2820R5BL](#) [BU15-4421R3BL](#) [BU16-2530R7BL](#) [BU9-6011R0BL](#) [BU16-1031R0BL](#) [BU10-1012R2BL](#) [BU9H-2011R6BL](#) [BU9H-103R25BL](#) [BU16-4530R5BL](#) [BU15-7521R0BL](#) [BU15-4530R4BL](#) [BU16-2022R0BL](#) [BU9-1320R7BL](#) [BU9-2011R6BL](#) [BU10-6003R0BL](#) [BU9H-6011R0BL](#) [BU10-1811R2BL](#) [BU9H-1320R7BL](#) [BU9-103R25BL](#) [BU9H-2820R5BL](#) [BU15-2721R6BL](#) [BU16-4021R5BL](#) [BU10-1311R6BL](#) [BU15-1430R7BL](#) [BU9S-7020R3BL](#) [BU9S-153R15BL](#) [BU9HS-7020R3BL](#)