

# BLM7G1822S-40PB; BLM7G1822S-40PBG

LDMOS 2-stage power MMIC

Rev. 5 — 24 February 2016

AMPLEON

Product data sheet

## 1. Product profile

### 1.1 General description

The BLM7G1822S-40PB(G) is a dual section, 2-stage power MMIC using Ampleon's state of the art GEN7 LDMOS technology. This multiband device is perfectly suited as general purpose driver or small cell final in the frequency range from 1805 MHz to 2170 MHz. Available in gull wing or straight lead outline.

**Table 1. Application performance**

Typical RF performance at  $T_{case} = 25\text{ °C}$ ;  $I_{Dq1} = 40\text{ mA}$ ;  $I_{Dq2} = 120\text{ mA}$ .

Test signal: 3GPP test model 1; 64 DPCH; PAR = 10 dB at 0.01% probability on CCDF; per section unless otherwise specified in a class-AB production circuit.

Test signal	f	V <sub>DS</sub>	P <sub>L(AV)</sub>	G <sub>p</sub>	η <sub>D</sub>	ACPR <sub>5M</sub>
	(MHz)	(V)	(W)	(dB)	(%)	(dBc)
single carrier W-CDMA	2167.5	28	4	31.5	25	-38.5

### 1.2 Features and benefits

- Designed for broadband operation (frequency 1805 MHz to 2170 MHz)
- High section-to-section isolation enabling multiple combinations
- Integrated temperature compensated bias
- Biasing of individual stages is externally accessible
- Integrated ESD protection
- Excellent thermal stability
- High power gain
- On-chip matching for ease of use
- Compliant to Directive 2002/95/EC, regarding restriction of hazardous substances (RoHS)

### 1.3 Applications

- RF power MMIC for W-CDMA base stations in the 1805 MHz to 2170 MHz frequency range. Possible circuit topologies are the following as also depicted in [Section 8.1](#):
  - ◆ Dual section or single ended
  - ◆ Doherty
  - ◆ Quadrature combined
  - ◆ Push-pull

## 2. Pinning information

### 2.1 Pinning

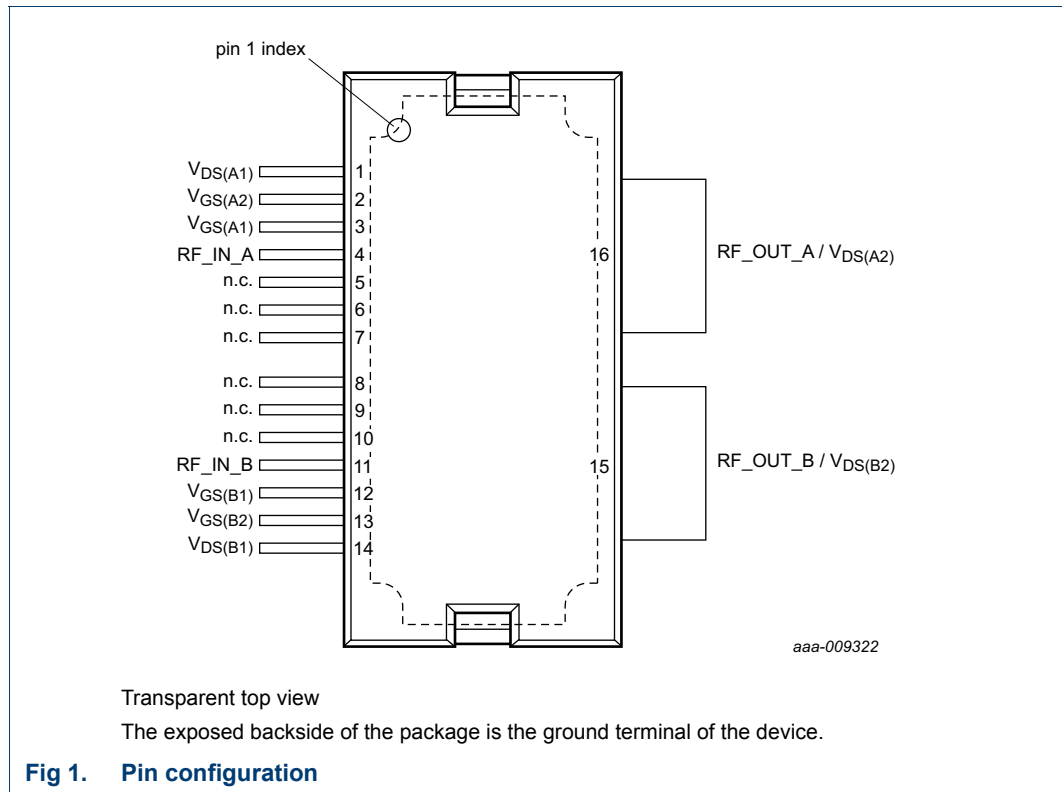

### 2.2 Pin description

Table 2. Pin description

Symbol	Pin	Description
$V_{DS(A1)}$	1	drain-source voltage of stage A1
$V_{GS(A2)}$	2	gate-source voltage of stage A2
$V_{GS(A1)}$	3	gate-source voltage of stage A1
RF_IN_A	4	RF input section A
n.c.	5	not connected
n.c.	6	not connected
n.c.	7	not connected
n.c.	8	not connected
n.c.	9	not connected
n.c.	10	not connected
RF_IN_B	11	RF input section B
$V_{GS(B1)}$	12	gate-source voltage of stage B1
$V_{GS(B2)}$	13	gate-source voltage of stage B2
$V_{DS(B1)}$	14	drain-source voltage of stage B1

Table 2. Pin description ...continued

Symbol	Pin	Description
RF_OUT_B/ $V_{DS(B2)}$	15	RF output section B / drain-source voltage of stage B2
RF_OUT_A/ $V_{DS(A2)}$	16	RF output section A / drain-source voltage of stage A2
GND	flange	RF ground

### 3. Ordering information

Table 3. Ordering information

Type number	Package		
	Name	Description	Version
BLM7G1822S-40PB	HSOP16F	plastic, heatsink small outline package; 16 leads (flat)	SOT1211-2
BLM7G1822S-40PBG	HSOP16	plastic, heatsink small outline package; 16 leads	SOT1212-2

### 4. Block diagram

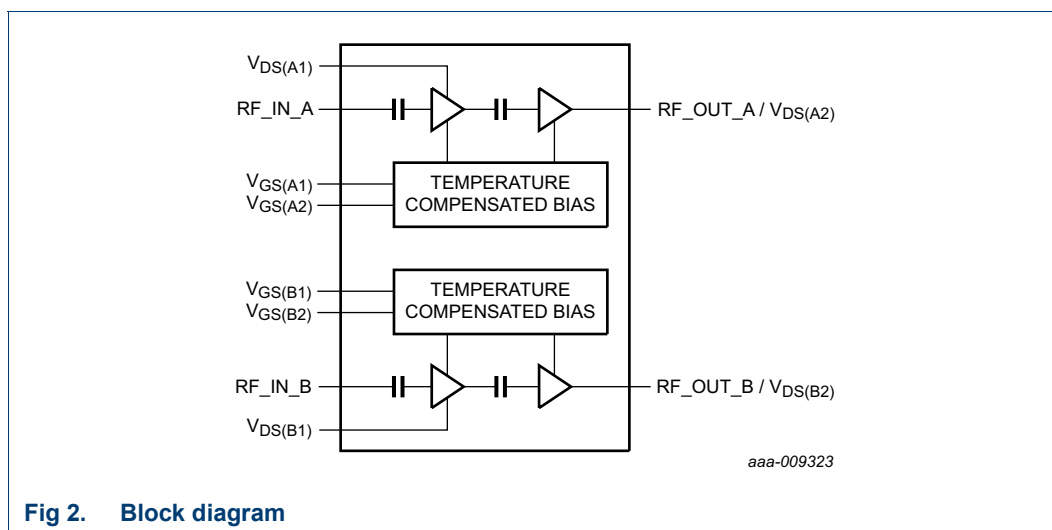

Fig 2. Block diagram

### 5. Limiting values

Table 4. Limiting values

In accordance with the Absolute Maximum Rating System (IEC 60134).

Symbol	Parameter	Conditions	Min	Max	Unit
$V_{DS}$	drain-source voltage		-	65	V
$V_{GS}$	gate-source voltage		-0.5	+13	V
$T_{stg}$	storage temperature		-65	+150	°C
$T_j$	junction temperature	[1]	-	225	°C
$T_{case}$	case temperature		-	150	°C

[1] Continuous use at maximum temperature will affect the reliability. For details refer to the online MTF calculator.

## 6. Thermal characteristics

**Table 5. Thermal characteristics**  
Measured for total device.

Symbol	Parameter	Conditions	Value	Unit
R <sub>th(j-c)</sub>	thermal resistance from junction to case	final stage; T <sub>case</sub> = 90 °C; P <sub>L</sub> = 2.52 W [1]	1.2	K/W
		driver stage; T <sub>case</sub> = 90 °C; P <sub>L</sub> = 2.52 W [1]	3.8	K/W

[1] When operated with a CW signal.

## 7. Characteristics

**Table 6. DC characteristics**  
T<sub>case</sub> = 25 °C; per section unless otherwise specified.

Symbol	Parameter	Conditions	Min	Typ	Max	Unit
<b>Final stage</b>						
V <sub>(BR)DSS</sub>	drain-source breakdown voltage	V <sub>GS</sub> = 0 V; I <sub>D</sub> = 0.302 mA	65	-	-	V
V <sub>GS(th)</sub>	gate-source threshold voltage	V <sub>DS</sub> = 10 V; I <sub>D</sub> = 30.2 mA	1.4	1.8	2.4	V
V <sub>GSq</sub>	gate-source quiescent voltage	V <sub>DS</sub> = 28 V; I <sub>D</sub> = 120 mA	1.55	1.9	2.45	V
		V <sub>DS</sub> = 28 V; I <sub>D</sub> = 120 mA [1]	1.9	2.3	3.3	V
I <sub>DSS</sub>	drain leakage current	V <sub>GS</sub> = 0 V; V <sub>DS</sub> = 28 V	-	-	1.4	μA
I <sub>DSX</sub>	drain cut-off current	V <sub>GS</sub> = V <sub>GS(th)</sub> + 3.75 V; V <sub>DS</sub> = 10 V	-	5.4	-	A
I <sub>GSS</sub>	gate leakage current	V <sub>GS</sub> = 1.0 V; V <sub>DS</sub> = 0 V	-	-	140	nA
<b>Driver stage</b>						
V <sub>(BR)DSS</sub>	drain-source breakdown voltage	V <sub>GS</sub> = 0 V; I <sub>D</sub> = 0.058 mA	65	-	-	V
V <sub>GS(th)</sub>	gate-source threshold voltage	V <sub>DS</sub> = 10 V; I <sub>D</sub> = 5.8 mA	1.4	1.8	2.4	V
V <sub>GSq</sub>	gate-source quiescent voltage	V <sub>DS</sub> = 28 V; I <sub>D</sub> = 40 mA	1.65	2	2.55	V
		V <sub>DS</sub> = 28 V; I <sub>D</sub> = 40 mA [2]	1.9	2.4	3.2	V
I <sub>DSS</sub>	drain leakage current	V <sub>GS</sub> = 0 V; V <sub>DS</sub> = 28 V	-	-	1.4	μA
I <sub>DSX</sub>	drain cut-off current	V <sub>GS</sub> = V <sub>GS(th)</sub> + 3.75 V; V <sub>DS</sub> = 10 V	-	1.04	-	A
I <sub>GSS</sub>	gate leakage current	V <sub>GS</sub> = 1.0 V; V <sub>DS</sub> = 0 V	-	-	140	nA

[1] In production circuit with 825 Ω gate feed resistor.

[2] In production circuit with 850 Ω gate feed resistor.

**Table 7. RF Characteristics**

Typical RF performance at  $T_{case} = 25\text{ °C}$ ;  $V_{DS} = 28\text{ V}$ ;  $I_{Dq1} = 40\text{ mA}$ ;  $I_{Dq2} = 120\text{ mA}$ ;  $P_{L(AV)} = 4\text{ W}$ . Per section unless otherwise specified, measured in an Ampleon wideband  $f = 1807.5\text{ MHz}$  to  $2167.5\text{ MHz}$  production circuit.

Symbol	Parameter	Conditions	Min	Typ	Max	Unit
<b>Test signal: single carrier W-CDMA [1]</b>						
$G_p$	power gain	$f = 1807.5\text{ MHz}$	-	31	-	dB
		$f = 2167.5\text{ MHz}$	30	31.5	33	dB
$\eta_D$	drain efficiency	$f = 1807.5\text{ MHz}$	-	24.5	-	%
		$f = 2167.5\text{ MHz}$	22	25	-	%
$RL_{in}$	input return loss	$f = 2167.5\text{ MHz}$	-	-15	-10	dB
$ACPR_{5M}$	adjacent channel power ratio (5 MHz)	$f = 1807.5\text{ MHz}$	-	-40.5	-	dBc
		$f = 2167.5\text{ MHz}$	-	-38.5	-36.5	dBc
$PAR_O$	output peak-to-average ratio	$f = 1807.5\text{ MHz}$	-	8	-	dB
		$f = 2167.5\text{ MHz}$	7.2	7.7	-	dB
$\Delta I_{Dq}/\Delta T$	quiescent drain current variation with temperature	$T = -40\text{ °C}$ to $+85\text{ °C}$				
		final stage $I_{Dq}$ ; gate feed resistor = $825\ \Omega$	-	$\pm 1$	-	%
		driver stage $I_{Dq}$ ; gate feed resistor = $850\ \Omega$	-	$\pm 1$	-	%
<b>Test signal: CW [2]</b>						
$\Delta\phi_{s21}$	phase response difference	between sections	-10	-	+10	deg
$\Delta S_{21} ^2$	insertion power gain difference	between sections	-0.5	-	+0.5	dB

[1] 3GPP test model 1; 64 DPCH; PAR = 10 dB at 0.01% probability on CCDF.

[2]  $f = 2170\text{ MHz}$ .

## 8. Application information

**Table 8. Typical performance**

Test signal: 1-tone CW; RF performance at  $T_{case} = 25\text{ °C}$ ;  $V_{DS} = 28\text{ V}$ ;  $I_{Dq1} = 80\text{ mA}$  (both sections);  $I_{Dq2} = 240\text{ mA}$  (both sections) unless otherwise specified, measured in an Ampleon wideband  $f = 1805\text{ MHz}$  to  $2170\text{ MHz}$  class AB application circuit.

Symbol	Parameter	Conditions	Min	Typ	Max	Unit
$P_{L(1dB)}$	output power at 1 dB gain compression	$f = 1960\text{ MHz}$	-	45.1	-	W
$\eta_D$	drain efficiency	at $P_{L(1dB)}$ ; $f = 1960\text{ MHz}$	-	53.3	-	%
$G_p$	power gain	$P_{L(AV)} = 4\text{ W}$ ; $f = 1960\text{ MHz}$	-	31.6	-	dB
$B_{video}$	video bandwidth	2-tone CW; $P_{L(AV)} = 4\text{ W}$ ; $f = 1960\text{ MHz}$	-	140	-	MHz
$G_{flat}$	gain flatness	$P_{L(AV)} = 4\text{ W}$	-	0.2	-	dB
$\Delta G/\Delta T$	gain variation with temperature	$f = 1960\text{ MHz}$	-	0.03	-	dB/°C
$ S_{12} ^2$	isolation	between sections A and B; $P_{L(AV)} = 4\text{ W}$ ; $f = 1960\text{ MHz}$	-	27.8	-	dB
K	Rollett stability factor	$T = -40\text{ °C}$ ; $f = 0.1\text{ GHz}$ to $3\text{ GHz}$	-	>1	-	

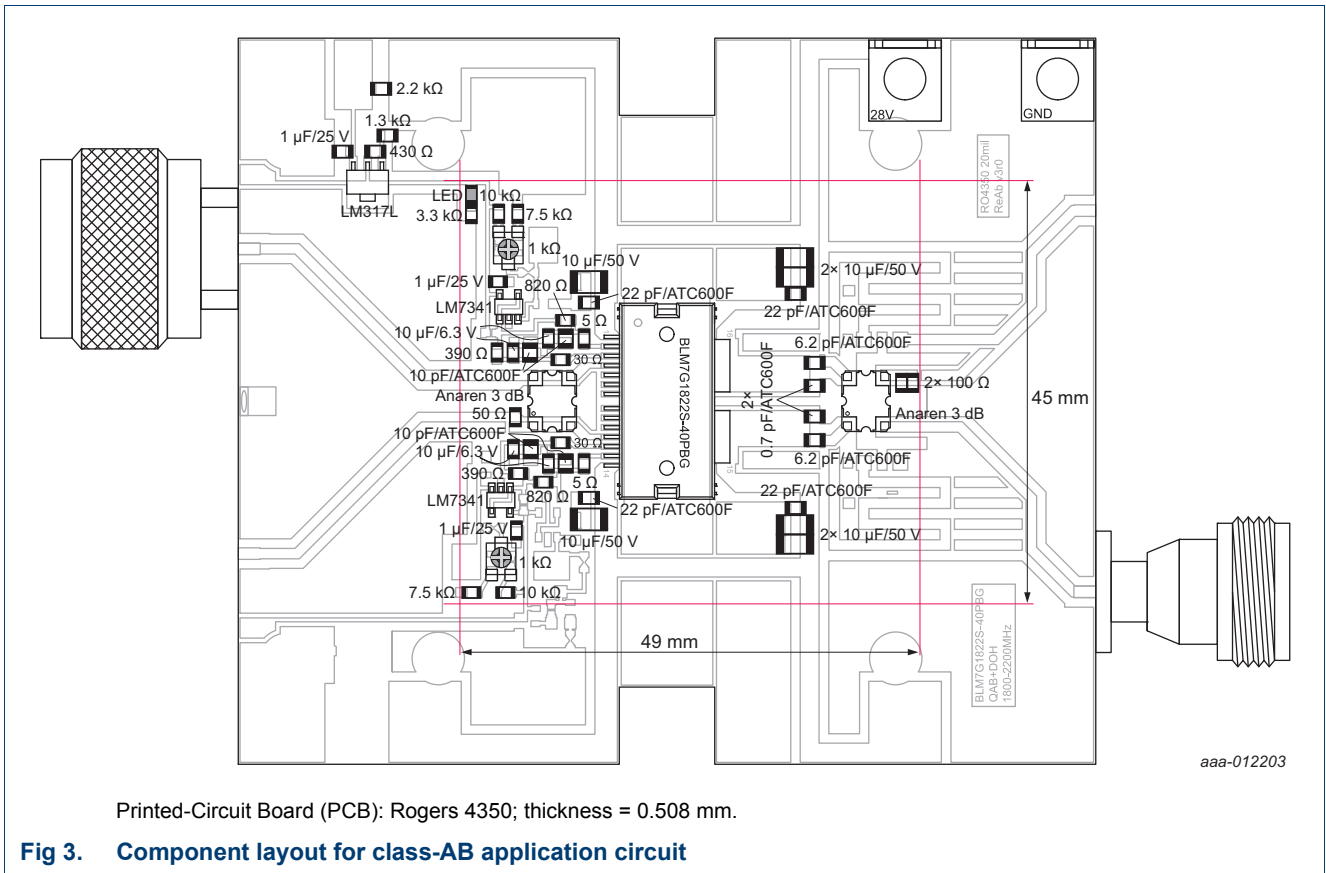

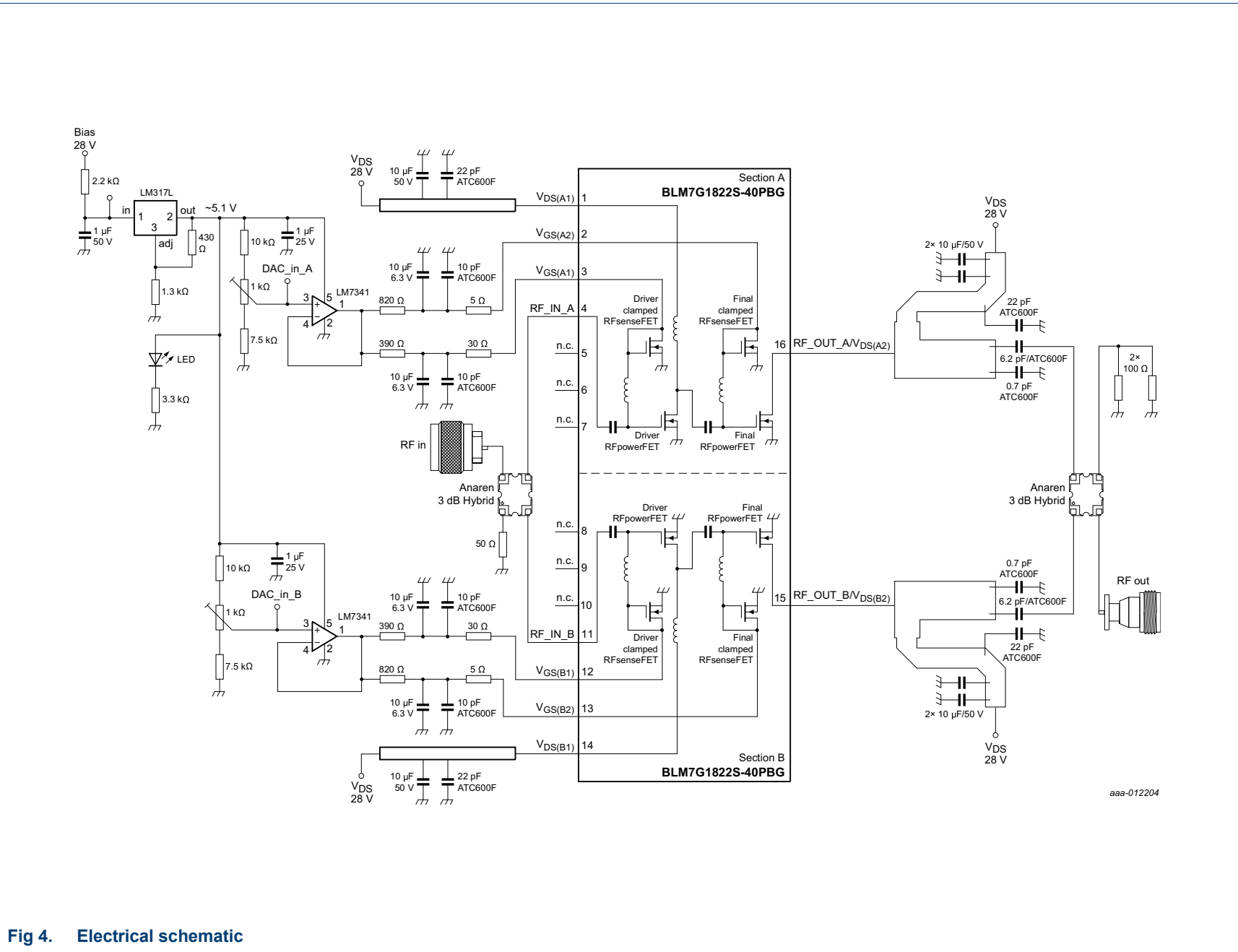

aaa-012204

Fig 4. Electrical schematic

8.1 Possible circuit topologies

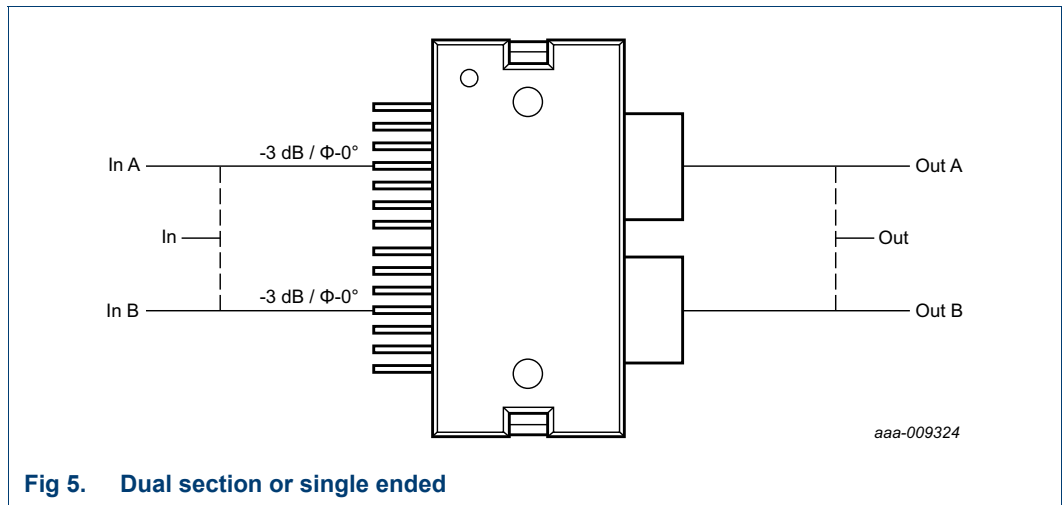

Fig 5. Dual section or single ended

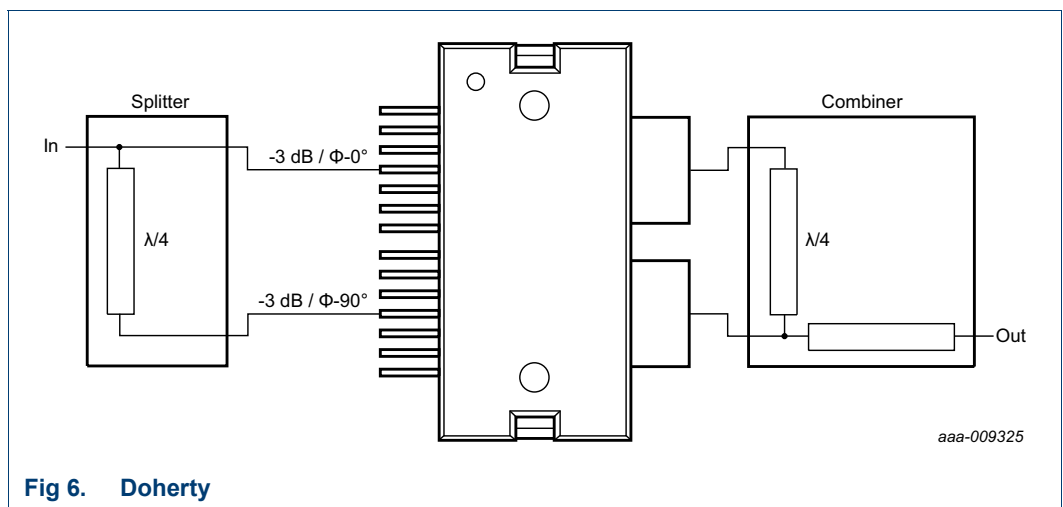

Fig 6. Doherty

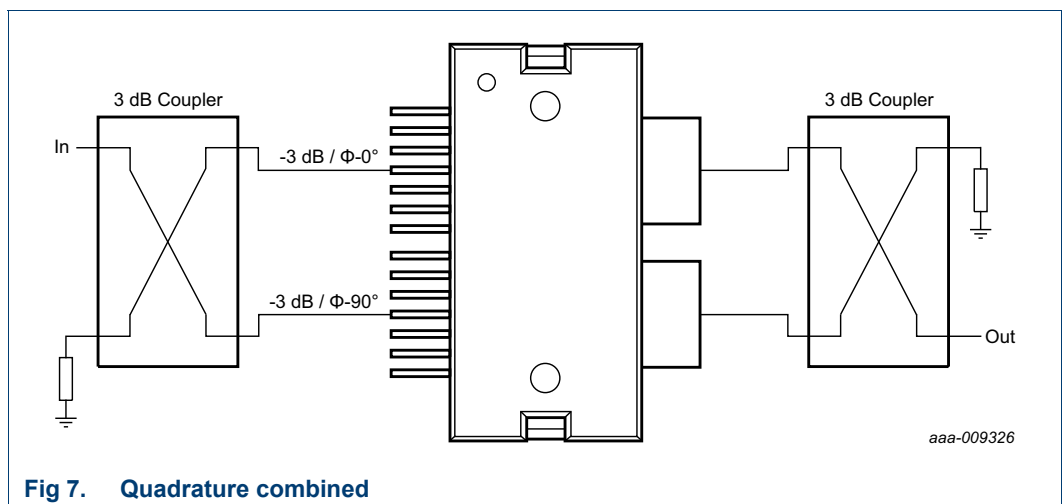
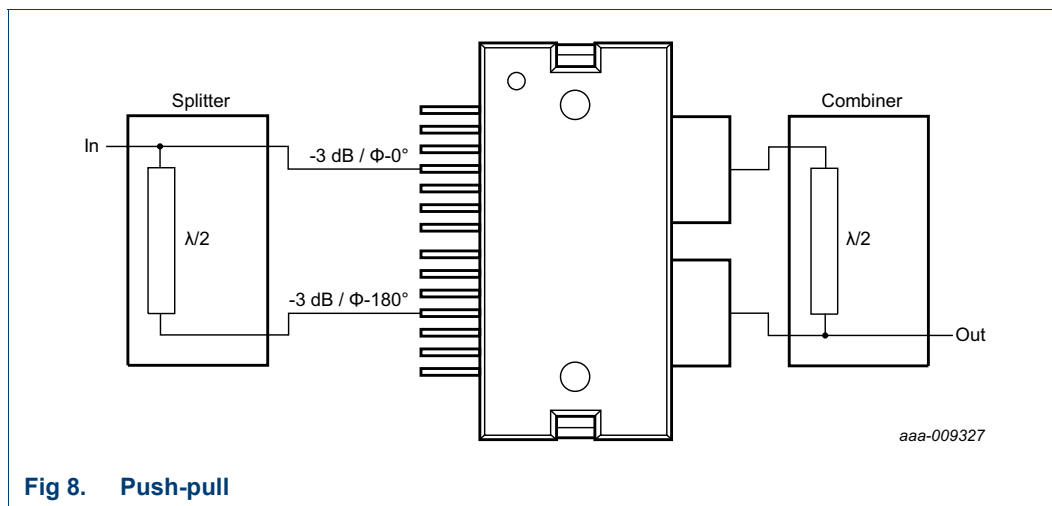

Fig 7. Quadrature combined





### 8.2 Ruggedness in class-AB operation

The BLM7G1822S-40PB and BLM7G1822S-40PBG are capable of withstanding a load mismatch corresponding to VSWR = 10 : 1 through all phases under the following conditions:  $V_{DS} = 28\text{ V}$ ;  $I_{Dq1} = 80\text{ mA}$ ;  $I_{Dq2} = 240\text{ mA}$ ;  $P_1 = 16\text{ dBm (CW)}$ ;  $f = 2140\text{ MHz}$ .

### 8.3 Impedance information

**Table 9. Typical impedance tuned for maximum output power**

Measured load-pull data per section; test signal: pulsed CW;  $T_{case} = 25\text{ °C}$ ;  $V_{DS} = 28\text{ V}$ ;  $I_{Dq1} = 40\text{ mA}$ ;  $I_{Dq2} = 110\text{ mA}$ ;  $t_p = 100\text{ }\mu\text{s}$ ;  $\delta = 10\text{ %}$ ;  $Z_S = 50\text{ }\Omega$ . Typical values unless otherwise specified.

f (MHz)	at 1dB gain compression point					at 3dB gain compression point				
	Z <sub>L</sub> (Ω)	G <sub>p(max)</sub> (dB)	P <sub>L</sub> (W)	η <sub>add</sub> (%)	AM-PM conversion (deg)	Z <sub>L</sub> (Ω)	G <sub>p(max)</sub> (dB)	P <sub>L</sub> (W)	η <sub>add</sub> (%)	AM-PM conversion (deg)
<b>BLM7G1822S-40PB</b>										
1805	7.2 – j9.2	32.2	45	48.3	1.7	7.7 – j10.6	32.2	45.8	51	0.3
1842.5	7.2 – j9.2	32.3	45	49	2.3	7.8 – j10.6	32.3	45.8	51.8	0.9
1880	7.2 – j9.2	32.4	44.9	49.9	2.7	7.7 – j10.6	32.3	45.8	52.1	1.4
1930	7.3 – j9.2	32.5	44.9	50.5	1.8	6.7 – j10.8	32	45.7	48.8	0.3
1960	7.2 – j9.2	32.7	45	50.8	3.3	7.8 – j10.6	32.6	45.7	51.4	1.6
1990	7.2 – j9.2	32.8	45	51	3.3	6.3 – j9.5	32.5	45.7	49.1	0.5
2110	6.3 – j9.5	33	45.2	50.7	2.2	6.3 – j9.5	33	45.8	51.4	-4
2140	6.3 – j9.5	33	45.1	50.7	1.2	6.3 – j9.5	33	45.7	51.8	-5.9
2170	6.3 – j9.5	33	45.1	51.3	0.3	6.8 – j10.8	32.8	45.6	50.1	-7.5
<b>BLM7G1822S-40PBG</b>										
1805	8.7 – j11.9	32.1	45	50.8	-0.2	8.0 – j13.4	31.8	45.8	50.3	-1.7
1842.5	8.7 – j11.8	32.3	45	50.6	0.4	8.0 – j13.4	31.9	45.8	49.2	-1
1880	7.5 – j12.0	32.1	45	48.6	1.4	8.0 – j13.4	32.1	45.8	50	-0.3
1930	8.0 – j13.4	32.1	45	48.7	1.6	8.0 – j13.4	32.1	45.8	50.3	-0.6
1960	7.5 – j12.1	32.5	45	49.5	1.7	8.0 – j13.4	32.4	45.7	49.9	-0.4

**Table 9. Typical impedance tuned for maximum output power ...continued**

Measured load-pull data per section; test signal: pulsed CW;  $T_{case} = 25\text{ }^{\circ}\text{C}$ ;  $V_{DS} = 28\text{ V}$ ;  $I_{Dq1} = 40\text{ mA}$ ;  $I_{Dq2} = 110\text{ mA}$ ;  $t_p = 100\text{ }\mu\text{s}$ ;  $\delta = 10\text{ }\%$ ;  $Z_S = 50\text{ }\Omega$ . Typical values unless otherwise specified.

f	at 1dB gain compression point					at 3dB gain compression point				
	Z <sub>L</sub>	G <sub>p(max)</sub>	P <sub>L</sub>	$\eta_{add}$	AM-PM conversion	Z <sub>L</sub>	G <sub>p(max)</sub>	P <sub>L</sub>	$\eta_{add}$	AM-PM conversion
(MHz)	( $\Omega$ )	(dB)	(W)	(%)	(deg)	( $\Omega$ )	(dB)	(W)	(%)	(deg)
1990	8.0 – j13.3	32.6	45	49	2.4	7.7 – j15.2	32.2	45.7	47	-0.7
2110	8.1 – j13.4	33	45.2	51	0.8	8.1 – j13.4	33	45.8	52.1	-6.1
2140	6.5 – j12.8	32.7	45.1	49.9	-0.8	6.5 – j12.8	32.7	45.7	50.8	-8.9
2170	7.0 – j14.1	32.4	45.1	48.3	-1.5	7.0 – j14.1	32.4	45.6	49.1	-10

**Table 10. Typical impedance tuned for maximum power added efficiency**

Measured load-pull data per section; test signal: pulsed CW;  $T_{case} = 25\text{ }^{\circ}\text{C}$ ;  $V_{DS} = 28\text{ V}$ ;  $I_{Dq1} = 40\text{ mA}$ ;  $I_{Dq2} = 110\text{ mA}$ ;  $t_p = 100\text{ }\mu\text{s}$ ;  $\delta = 10\text{ }\%$ ;  $Z_S = 50\text{ }\Omega$ . Typical values unless otherwise specified.

f	at 1dB gain compression point					at 3dB gain compression point				
	Z <sub>L</sub>	G <sub>p(max)</sub>	P <sub>L</sub>	$\eta_{add}$	AM-PM conversion	Z <sub>L</sub>	G <sub>p(max)</sub>	P <sub>L</sub>	$\eta_{add}$	AM-PM conversion
(MHz)	( $\Omega$ )	(dB)	(W)	(%)	(deg)	( $\Omega$ )	(dB)	(W)	(%)	(deg)
<b>BLM7G1822S-40PB</b>										
1805	18.0 – j7.9	33.4	43.1	57.8	-0.6	16.7 – j4.2	33.5	43.9	58.8	-4.9
1842.5	16.6 – j4.0	33.5	43	58	-1.1	16.2 – j5.6	33.4	44	58.5	-3
1880	14.2 – j5.6	33.4	43.6	57.9	0.4	12.2 – j4.6	33.4	44.5	58.4	-2.8
1930	11.6 – j3.4	33.5	43.4	57.5	-1.6	11.6 – j3.4	33.5	44.1	57.7	-4.3
1960	9.9 – j4.4	33.6	43.9	57.5	0.3	9.9 – j4.4	33.6	44.6	57.6	-2.3
1990	10.8 – j3.1	33.7	43.4	57.4	0.2	8.6 – j4.3	33.6	44.6	57	-3.1
2110	7.3 – j4.8	33.8	43.9	57.5	-0.2	7.3 – j4.8	33.8	44.6	56.4	-4.4
2140	7.3 – j4.8	33.8	43.9	57.5	-0.5	7.3 – j4.8	33.8	44.5	56.2	-5.4
2170	7.0 – j6.3	33.6	44.3	57.2	-0.3	7.0 – j6.3	33.6	44.9	56.5	-7
<b>BLM7G1822S-40PBG</b>										
1805	18.8 – j9.7	33	43.2	57.4	-2.4	14.8 – j8.7	33	44.6	58.1	-5.5
1842.5	16.9 – j6.3	33.2	43.2	57.4	-2.7	16.3 – j4.3	33.3	44.7	57.5	-7.4
1880	15.3 – j5.5	33.3	43.2	57.2	-1.9	12.7 – j7.1	33.2	44.5	57.3	-4.3
1930	12.8 – j7.3	33.2	43.7	56.7	-0.9	12.8 – j7.3	33.2	44.4	56.3	-3.4
1960	11.1 – j6.8	33.5	43.8	56.5	-1	11.1 – j6.8	33.5	44.5	56.1	-3.6
1990	9.6 – j6.5	33.5	43.7	56.3	-0.9	9.0 – j7.7	33.4	44.8	55.9	-3.4
2110	9.0 – j7.7	33.7	44	57.1	-0.4	7.6 – j8.0	33.6	44.7	56.1	-6.7
2140	8.1 – j6.7	33.6	43.5	56.9	-1.6	7.6 – j8.0	33.5	44.5	55.7	-7.7
2170	6.4 – j7.7	33.3	43.6	57.2	-3	8.6 – j9.0	33.3	44.8	55.8	-7.8

8.4 Graphs

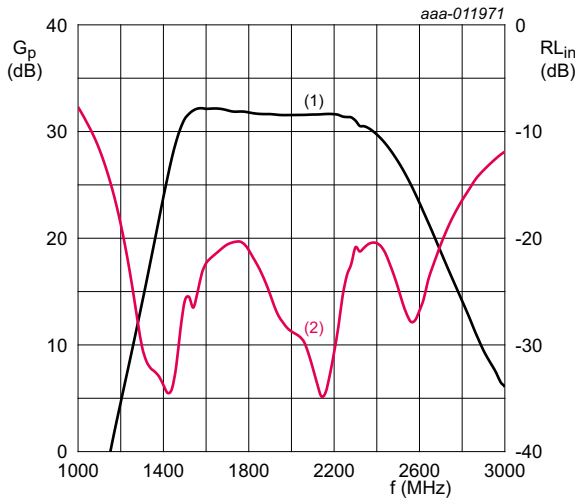

$T_{case} = 25\text{ }^{\circ}\text{C}$ ;  $V_{DS} = 28\text{ V}$ ;  $I_{DQ1} = 40\text{ mA}$ ;  $I_{DQ2} = 120\text{ mA}$ ;  $P_L = 4\text{ W}$ . Per section.

- (1) magnitude of  $G_p$
- (2) magnitude of  $RL_{in}$

Fig 9. Wideband power gain and input return loss as function of frequency; typical values

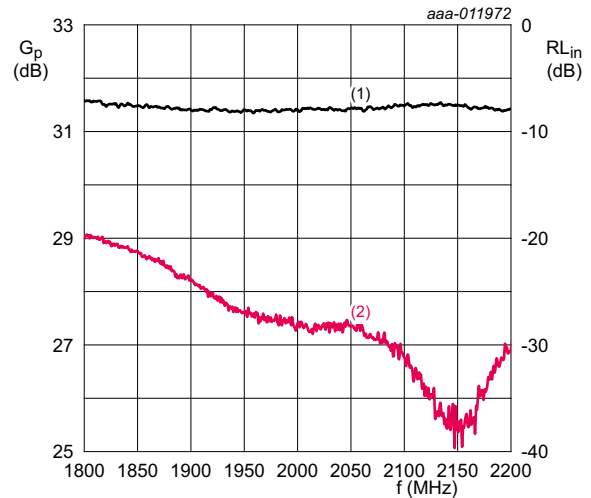

$T_{case} = 25\text{ }^{\circ}\text{C}$ ;  $V_{DS} = 28\text{ V}$ ;  $I_{DQ1} = 40\text{ mA}$ ;  $I_{DQ2} = 120\text{ mA}$ ;  $P_L = 4\text{ W}$ . Per section.

- (1) magnitude of  $G_p$
- (2) magnitude of  $RL_{in}$

Fig 10. In-band power gain and input return loss as function of frequency; typical values

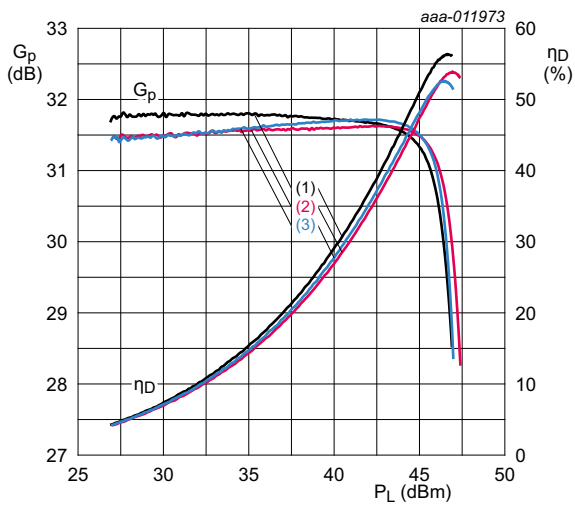

$T_{case} = 25\text{ }^{\circ}\text{C}$ ;  $V_{DS} = 28\text{ V}$ ;  $I_{DQ1} = 40\text{ mA}$ ;  $I_{DQ2} = 120\text{ mA}$ . Per section.

- (1)  $f = 1805\text{ MHz}$
- (2)  $f = 1960\text{ MHz}$
- (3)  $f = 2170\text{ MHz}$

Fig 11. Power gain and drain efficiency as function of output power; typical values

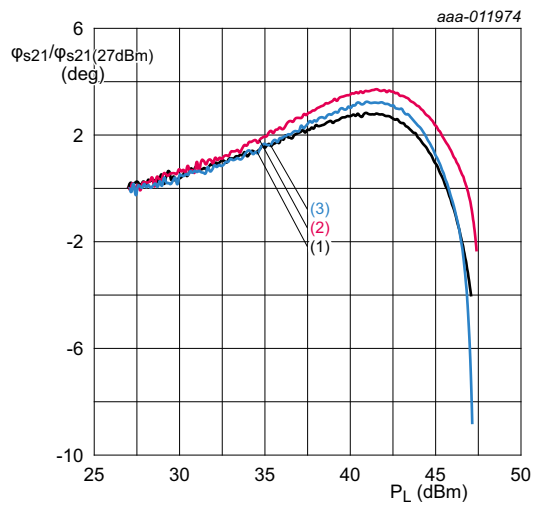

$T_{case} = 25\text{ }^{\circ}\text{C}$ ;  $V_{DS} = 28\text{ V}$ ;  $I_{DQ1} = 40\text{ mA}$ ;  $I_{DQ2} = 120\text{ mA}$ . Per section.

- (1)  $f = 1805\text{ MHz}$
- (2)  $f = 1960\text{ MHz}$
- (3)  $f = 2170\text{ MHz}$

Fig 12. 27 dBm normalized phase response as a function of output power; typical values

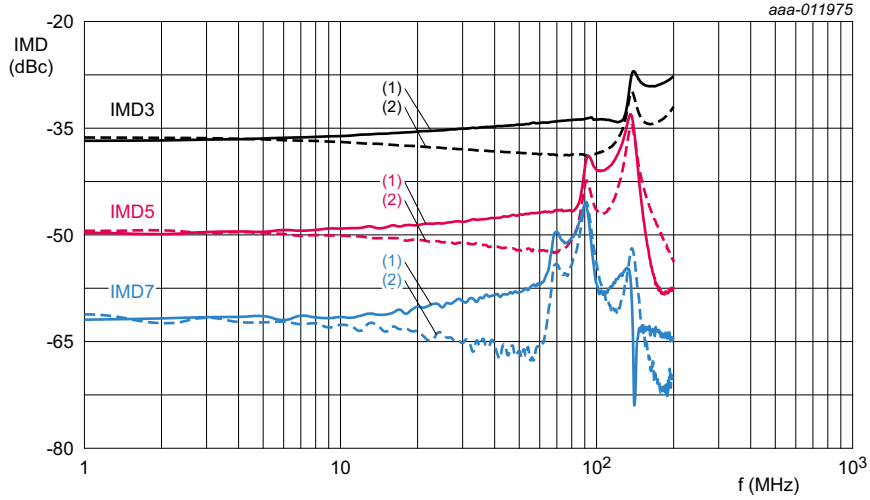

$T_{case} = 25\text{ }^{\circ}\text{C}$ ;  $V_{DS} = 28\text{ V}$ ;  $I_{Dq1} = 40\text{ mA}$ ;  $I_{Dq2} = 120\text{ mA}$ ;  $f = 1960\text{ MHz}$ ; 2-tone CW;  $P_{L(AV)} = 4\text{ W}$ . Per section.

- (1) IMD low
- (2) IMD high

**Fig 13. Intermodulation distortion as a function of tone spacing; typical values**

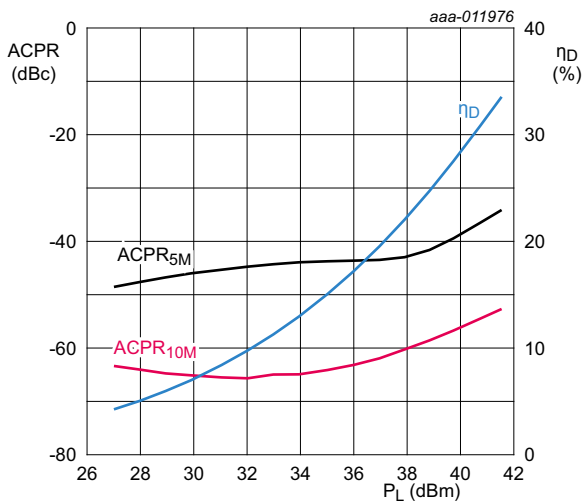

$T_{case} = 25\text{ }^{\circ}\text{C}$ ;  $V_{DS} = 28\text{ V}$ ;  $I_{Dq1} = 40\text{ mA}$ ;  $I_{Dq2} = 120\text{ mA}$ ;  
 $f = 1960\text{ MHz}$ ; 1-carrier W-CDMA; test model 1;  
 $PAR = 7.2\text{ dB}$  at 0.01 % probability on CCDF. Per section.

**Fig 14. Adjacent channel power ratio and drain efficiency as function of output power; typical values**

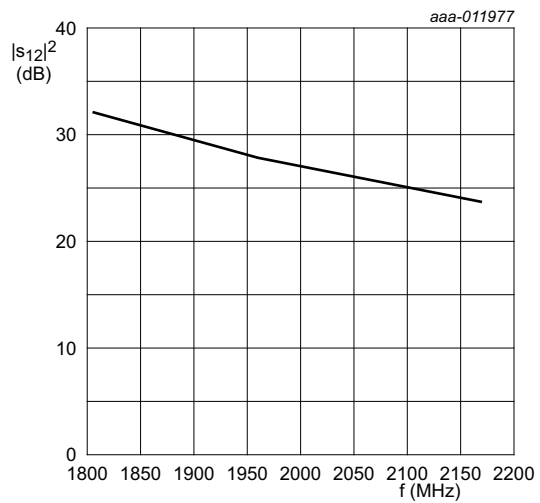

$T_{case} = 25\text{ }^{\circ}\text{C}$ ;  $V_{DS} = 28\text{ V}$ ;  $I_{Dq1} = 40\text{ mA}$ ;  $I_{Dq2} = 120\text{ mA}$ .  
 Per section.

**Fig 15. Isolation as a function of frequency; typical values**

9. Package outline

HSOP16F: plastic, heatsink small outline package; 16 leads(flat)

SOT1211-2

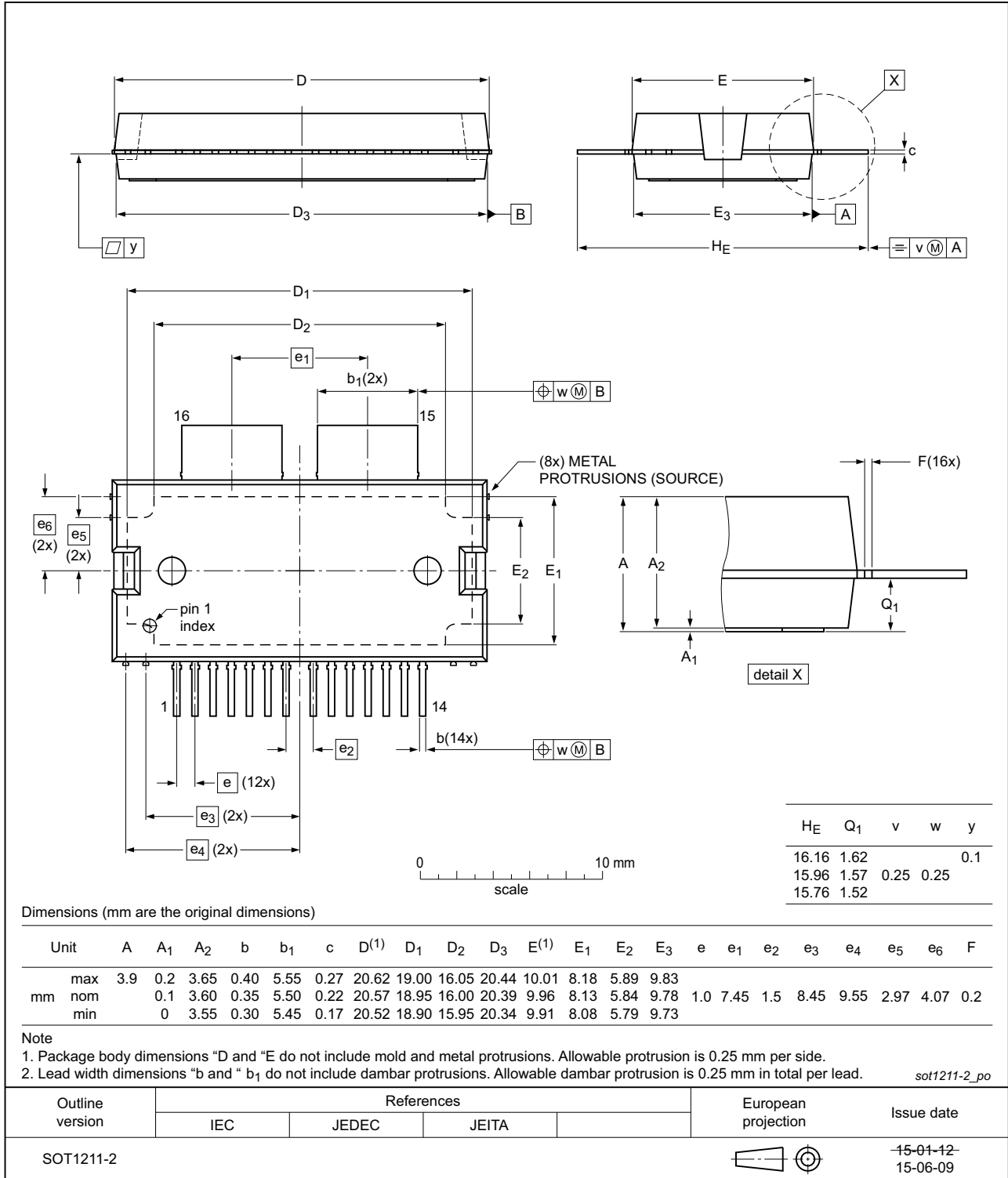

Fig 16. Package outline SOT1211-2 (HSOP16F)

HSOP16: plastic, heatsink small outline package; 16 leads

SOT1212-2

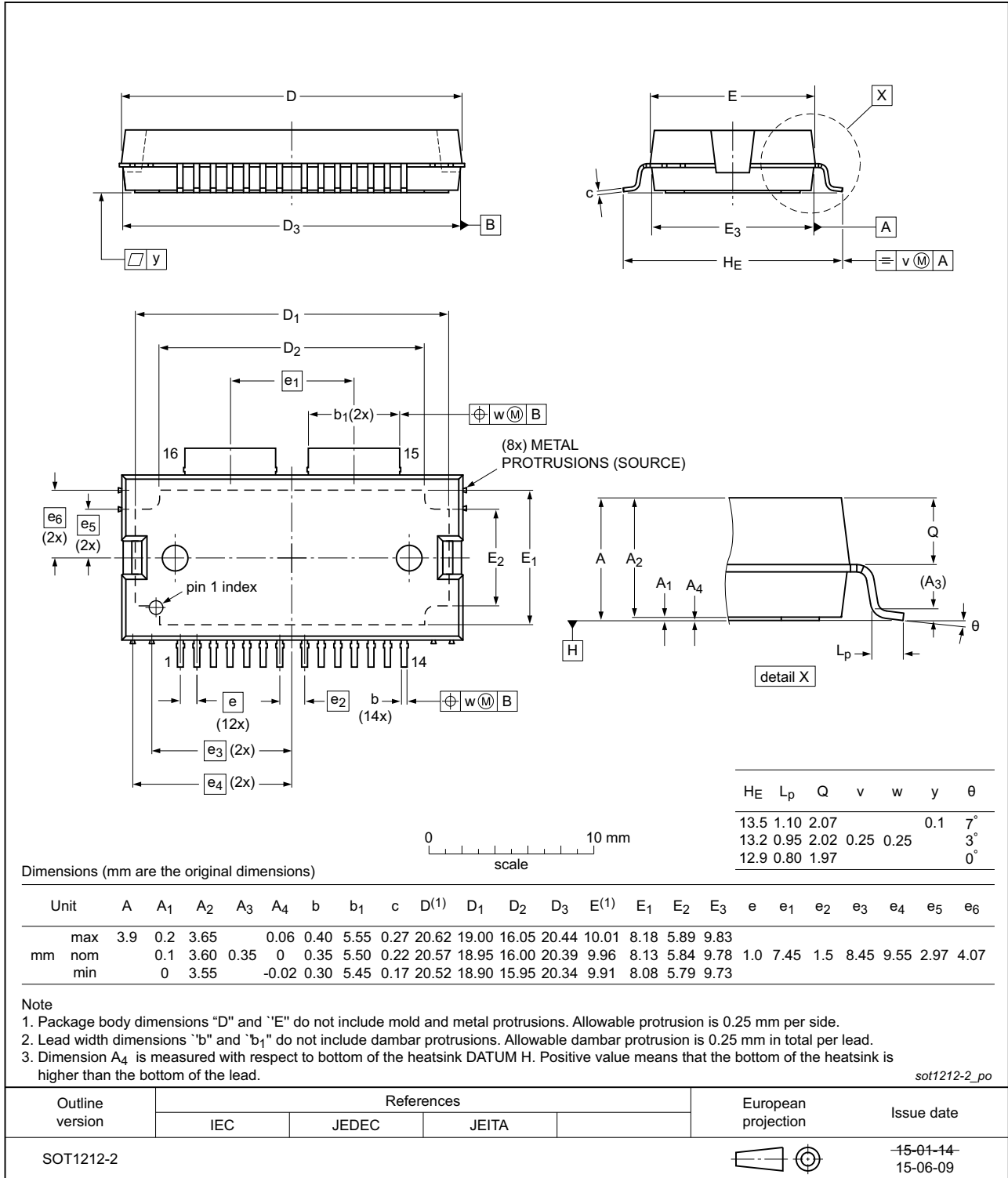

Fig 17. Package outline SOT1212-2 (HSOP16)

## 10. Handling information

### CAUTION



This device is sensitive to ElectroStatic Discharge (ESD). Observe precautions for handling electrostatic sensitive devices.

Such precautions are described in the *ANSI/ESD S20.20*, *IEC/ST 61340-5*, *JESD625-A* or equivalent standards.

## 11. Abbreviations

Table 11. Abbreviations

Acronym	Description
AM	Amplitude Modulation
3GPP	3rd Generation Partnership Project
CCDF	Complementary Cumulative Distribution Function
CW	Continuous Wave
DPCH	Dedicated Physical CHannel
ESD	ElectroStatic Discharge
GEN7	Seventh Generation
LDMOS	Laterally Diffused Metal Oxide Semiconductor
MMIC	Monolithic Microwave Integrated Circuit
MTF	Median Time to Failure
PAR	Peak-to-Average Ratio
PM	Phase Modulation
VSWR	Voltage Standing-Wave Ratio
W-CDMA	Wideband Code Division Multiple Access

## 12. Revision history

Table 12. Revision history

Document ID	Release date	Data sheet status	Change notice	Supersedes
BLM7G1822S-40PB_S-40PBG v.5	20160224	Product data sheet		BLM7G1822S-40PB_S-40PBG v.4
Modifications:	<ul style="list-style-type: none"> <li><a href="#">Table 6 on page 4</a>: table updated</li> </ul>			
BLM7G1822S-40PB_S-40PBG v.4	20150901	Product data sheet		BLM7G1822S-40PB_S-40PBG v.3
BLM7G1822S-40PB_S-40PBG v.3	20150701	Product data sheet	-	BLM7G1822S-40PB_S-40PBG v.2
BLM7G1822S-40PB_S-40PBG v.2	20140324	Product data sheet	-	BLM7G1822S-40PB_S-40PBG v.1
BLM7G1822S-40PB_S-40PBG v.1	20131009	Objective data sheet	-	-

## 13. Legal information

### 13.1 Data sheet status

Document status <sup>[1][2]</sup>	Product status <sup>[3]</sup>	Definition
Objective [short] data sheet	Development	This document contains data from the objective specification for product development.
Preliminary [short] data sheet	Qualification	This document contains data from the preliminary specification.
Product [short] data sheet	Production	This document contains the product specification.

[1] Please consult the most recently issued document before initiating or completing a design.

[2] The term 'short data sheet' is explained in section "Definitions".

[3] The product status of device(s) described in this document may have changed since this document was published and may differ in case of multiple devices. The latest product status information is available on the Internet at URL <http://www.ampleon.com>.

### 13.2 Definitions

**Draft** — The document is a draft version only. The content is still under internal review and subject to formal approval, which may result in modifications or additions. Ampleon does not give any representations or warranties as to the accuracy or completeness of information included herein and shall have no liability for the consequences of use of such information.

**Short data sheet** — A short data sheet is an extract from a full data sheet with the same product type number(s) and title. A short data sheet is intended for quick reference only and should not be relied upon to contain detailed and full information. For detailed and full information see the relevant full data sheet, which is available on request via the local Ampleon sales office. In case of any inconsistency or conflict with the short data sheet, the full data sheet shall prevail.

**Product specification** — The information and data provided in a Product data sheet shall define the specification of the product as agreed between Ampleon and its customer, unless Ampleon and customer have explicitly agreed otherwise in writing. In no event however, shall an agreement be valid in which the Ampleon product is deemed to offer functions and qualities beyond those described in the Product data sheet.

Ampleon product can reasonably be expected to result in personal injury, death or severe property or environmental damage. Ampleon and its suppliers accept no liability for inclusion and/or use of Ampleon products in such equipment or applications and therefore such inclusion and/or use is at the customer's own risk.

**Applications** — Applications that are described herein for any of these products are for illustrative purposes only. Ampleon makes no representation or warranty that such applications will be suitable for the specified use without further testing or modification.

Customers are responsible for the design and operation of their applications and products using Ampleon products, and Ampleon accepts no liability for any assistance with applications or customer product design. It is customer's sole responsibility to determine whether the Ampleon product is suitable and fit for the customer's applications and products planned, as well as for the planned application and use of customer's third party customer(s). Customers should provide appropriate design and operating safeguards to minimize the risks associated with their applications and products.

Ampleon does not accept any liability related to any default, damage, costs or problem which is based on any weakness or default in the customer's applications or products, or the application or use by customer's third party customer(s). Customer is responsible for doing all necessary testing for the customer's applications and products using Ampleon products in order to avoid a default of the applications and the products or of the application or use by customer's third party customer(s). Ampleon does not accept any liability in this respect.

**Limiting values** — Stress above one or more limiting values (as defined in the Absolute Maximum Ratings System of IEC 60134) will cause permanent damage to the device. Limiting values are stress ratings only and (proper) operation of the device at these or any other conditions above those given in the Recommended operating conditions section (if present) or the Characteristics sections of this document is not warranted. Constant or repeated exposure to limiting values will permanently and irreversibly affect the quality and reliability of the device.

**Terms and conditions of commercial sale** — Ampleon products are sold subject to the general terms and conditions of commercial sale, as published at <http://www.ampleon.com/terms>, unless otherwise agreed in a valid written individual agreement. In case an individual agreement is concluded only the terms and conditions of the respective agreement shall apply. Ampleon hereby expressly objects to applying the customer's general terms and conditions with regard to the purchase of Ampleon products by customer.

**No offer to sell or license** — Nothing in this document may be interpreted or construed as an offer to sell products that is open for acceptance or the grant, conveyance or implication of any license under any copyrights, patents or other industrial or intellectual property rights.

**Export control** — This document as well as the item(s) described herein may be subject to export control regulations. Export might require a prior authorization from competent authorities.

### 13.3 Disclaimers

**Limited warranty and liability** — Information in this document is believed to be accurate and reliable. However, Ampleon does not give any representations or warranties, expressed or implied, as to the accuracy or completeness of such information and shall have no liability for the consequences of use of such information. Ampleon takes no responsibility for the content in this document if provided by an information source outside of Ampleon.

In no event shall Ampleon be liable for any indirect, incidental, punitive, special or consequential damages (including - without limitation - lost profits, lost savings, business interruption, costs related to the removal or replacement of any products or rework charges) whether or not such damages are based on tort (including negligence), warranty, breach of contract or any other legal theory.

Notwithstanding any damages that customer might incur for any reason whatsoever, Ampleon's aggregate and cumulative liability towards customer for the products described herein shall be limited in accordance with the *Terms and conditions of commercial sale* of Ampleon.

**Right to make changes** — Ampleon reserves the right to make changes to information published in this document, including without limitation specifications and product descriptions, at any time and without notice. This document supersedes and replaces all information supplied prior to the publication hereof.

**Suitability for use** — Ampleon products are not designed, authorized or warranted to be suitable for use in life support, life-critical or safety-critical systems or equipment, nor in applications where failure or malfunction of an



**Non-automotive qualified products** — Unless this data sheet expressly states that this specific Ampleon product is automotive qualified, the product is not suitable for automotive use. It is neither qualified nor tested in accordance with automotive testing or application requirements. Ampleon accepts no liability for inclusion and/or use of non-automotive qualified products in automotive equipment or applications.

In the event that customer uses the product for design-in and use in automotive applications to automotive specifications and standards, customer (a) shall use the product without Ampleon' warranty of the product for such automotive applications, use and specifications, and (b) whenever customer uses the product for automotive applications beyond Ampleon' specifications such use shall be solely at customer's own risk, and (c) customer fully indemnifies Ampleon for any liability, damages or failed product claims resulting from customer design and use of the product for automotive applications beyond Ampleon' standard warranty and Ampleon' product specifications.

**Translations** — A non-English (translated) version of a document is for reference only. The English version shall prevail in case of any discrepancy between the translated and English versions.

## 13.4 Trademarks

Notice: All referenced brands, product names, service names and trademarks are the property of their respective owners.

Any reference or use of any 'NXP' trademark in this document or in or on the surface of Ampleon products does not result in any claim, liability or entitlement vis-à-vis the owner of this trademark. Ampleon is no longer part of the NXP group of companies and any reference to or use of the 'NXP' trademarks will be replaced by reference to or use of Ampleon's own trademarks.

## 14. Contact information

For more information, please visit: <http://www.ampleon.com>

For sales office addresses, please visit: <http://www.ampleon.com/sales>

**15. Contents**

**1 Product profile . . . . . 1**

1.1 General description . . . . . 1

1.2 Features and benefits . . . . . 1

1.3 Applications . . . . . 1

**2 Pinning information . . . . . 2**

2.1 Pinning . . . . . 2

2.2 Pin description . . . . . 2

**3 Ordering information . . . . . 3**

**4 Block diagram . . . . . 3**

**5 Limiting values . . . . . 3**

**6 Thermal characteristics . . . . . 4**

**7 Characteristics . . . . . 4**

**8 Application information . . . . . 5**

8.1 Possible circuit topologies . . . . . 8

8.2 Ruggedness in class-AB operation . . . . . 9

8.3 Impedance information . . . . . 9

8.4 Graphs . . . . . 11

**9 Package outline . . . . . 13**

**10 Handling information . . . . . 15**

**11 Abbreviations . . . . . 15**

**12 Revision history . . . . . 15**

**13 Legal information . . . . . 16**

13.1 Data sheet status . . . . . 16

13.2 Definitions . . . . . 16

13.3 Disclaimers . . . . . 16

13.4 Trademarks . . . . . 17

**14 Contact information . . . . . 17**

**15 Contents . . . . . 18**

Please be aware that important notices concerning this document and the product(s) described herein, have been included in section 'Legal information'.

© Ampleon Netherlands B.V. 2016. All rights reserved.

For more information, please visit: <http://www.ampleon.com>  
 For sales office addresses, please visit: <http://www.ampleon.com/sales>

Date of release: 24 February 2016

Document identifier: BLM7G1822S-40PB\_S-40PBG