

BMA145

Analog, triaxial acceleration sensor

Bosch Sensortec



BOSCH
Invented for life

General description

The BMA145 is an analog, triaxial low-g acceleration sensor for consumer market applications, available in a super-flat land-grid array (LGA) package with a very small footprint of 4mm x 4mm and a height of merely 0.9mm. It allows measurements of static as well as dynamic accelerations. Due to its three perpendicular axes it gives the absolute orientation in a gravity field and enables free-fall detection.

The BMA145 is a two-chip arrangement, which combines an application-specific integrated circuit (ASIC) with a three-channel silicon accelerometer, to form a true micro electro mechanical system (MEMS).

Key features BMA145

- ▶ Triaxial, analog low-g sensor with three parallel outputs
- ▶ $\pm 4g$ range
- ▶ Ultra-low power consumption
- ▶ Power-saving stand-by mode
- ▶ Fast wake-up time
- ▶ Very wide power supply range
- ▶ Additional multiplexed serial analog output
- ▶ Internal filtering capability
- ▶ On-chip gain and offset compensation
- ▶ Self-test capability
- ▶ Super-flat, small footprint LGA package
- ▶ RoHS compliant

This concept and the advanced micromachining technology have proven their robustness and reliability in more than 150 million Bosch MEMS sensors per year. The modular ASIC design provides the flexibility to react quickly to customer needs for additional sensor functionality in the future.

The BMA145 provides three parallel analog output signals in a $\pm 4g$ acceleration range. In addition to the parallel X, Y and Z output signals there is the option to multiplex any axis to a single supplementary output pin in a freely customized manner.

Leveraging its ultra-low power consumption and its wake-up feature the BMA145 senses tilt, motion, shock and vibration in advanced gaming console applications and all kind of mobile, personal communication and entertainment devices.

BMA145 applications based on low-g sensing

- ▶ Gaming
- ▶ Virtual reality
- ▶ Sports- and life-style wear
- ▶ Handhelds
- ▶ Healthcare
- ▶ Cell phones
- ▶ Navigation
- ▶ Electronic compass compensation

Technical data	BMA145
Sensitive axes	x/y/z
Measurement range	$\pm 4g$
Package	LGA, 4 mm x 4 mm x 0.9 mm
Sensitivity (factory trimmed)	$V_{DD}/10$ [V/g]
Non-linearity	± 0.5 % FS (typ.)
Cross axis sensitivity	0.2 % (typ.)
Zero-g offset (factory trimmed)	± 150 mg (max.)
Zero-g offset temperature drift	± 1 mg/K (typ.)
RMS-noise	220 $\mu g/\sqrt{Hz}$
Bandwidth (1 st order LP filtering)	1.5 kHz
Supply voltage	1.8 ... 3.5 V
Current consumption (typ., normal mode)	200 μA
Idle current (max., stand-by mode)	0.9 μA
Wake-up time	1 msec (typ.)
Temperature range	-40 °C ... +85 °C

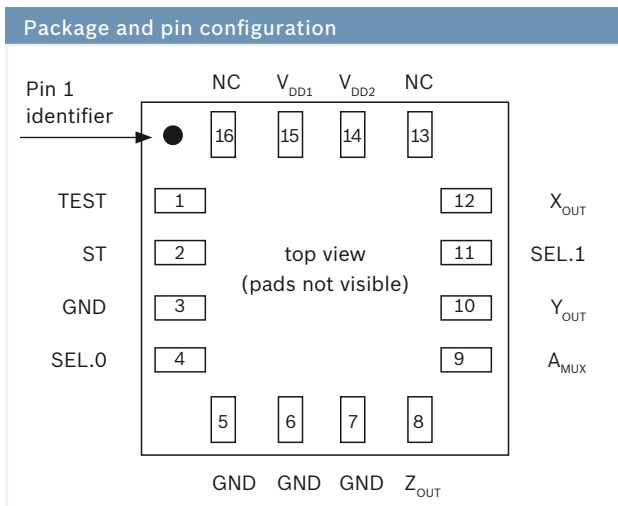

Pin No.	Name	Function
1	TEST	Do not connect
2	ST	Self-test activation
3	GND	Ground connection
4	SEL.0	Multiplexer selection
5	GND	Ground connection
6	GND	Ground connection
7	GND	Ground connection
8	Z _{OUT}	Z acceleration output
9	A _{MUX}	Multiplex serial output
10	Y _{OUT}	Y acceleration output
11	SEL.1	Multiplexer selection
12	X _{OUT}	X acceleration output
13	NC	Not connected
14	V _{DD2}	Supply voltage
15	V _{DD1}	Supply voltage
16	NC	Not connected

Sensor operation

The BMA145 provides three parallel analog output signals in a $\pm 4g$ acceleration range. All acceleration signals are permanently available on three independen-

dent analog pads through $33k\Omega$ resistors on each pad. For each axis, an independent analog $1.5kHz$ 1st-order low-pass filter is included to provide pre-conditioning of the measured acceleration signal. In combination with the integrated $33k\Omega$ resistors, the corner frequency of this filter can easily be customized by the use of external capacitors. Additional signal preconditioning steps are performed by a digital-to-analog converter for offset and gain correction purposes with a subsequent signal amplification. All output signals are fully ratio-metric.

With an acceleration range of $\pm 4g$ the BMA145 provides a sensitivity of $300mV/g$ at $3.0V$ supply voltage ($V_{DD}/10$) and $220\mu g/\sqrt{Hz}$ as a typical RMS noise level. The typical current consumption is only $200\mu A$ in normal operation mode.

In addition to the parallel X, Y and Z output signals there is the option to multiplex any axis to one single supplementary output pin in a freely customized manner, thus requiring only one A/D channel.

Furthermore, the BMA145 can be switched into stand-by mode via supplementary selection pins. In this mode the sensor module features an ultra-low current consumption of only $0.9\mu A$ at maximum. The return from stand-by mode to normal mode takes less than 1 millisecond wake up time.

The BMA145 is ready to use due to test and calibration at factory level. All calibration parameters, e.g. for offset and sensitivity, are stored in an internal EEPROM.

The BMA145 also features full self-test capability for all three axes. It provides full testing of the complete signal evaluation path including the MEMS accelerationsensing element and the evaluation ASIC.

Headquarters

Bosch Sensortec GmbH

Gerhard-Kindler-Strasse 8
72770 Reutlingen · Germany
Telephone +49 7121 3535 900
Fax +49 7121 3535 909
contact@bosch-sensortec.com
www.bosch-sensortec.com