

BMA150

Digital, triaxial acceleration sensor

Bosch Sensortec



BOSCH

Invented for life

General description

The BMA150 is an LGA packaged triaxial, low-g acceleration sensor with digital output. Offering many smart functional features the BMA150 is aimed for consumer market applications. It allows measurements of accelerations in 3 perpendicular axes. An evaluation circuitry converts the output of a three-channel micromechanical acceleration sensing structure that works according to the differential capacitance principle.

The base of the micromachining technology has proven its capability in more than 100 million Bosch accelerometers and gyroscopes so far. The modular ASIC design provides a flexibility to react quickly to customer needs for additional sensor functionality in the future.

The BMA150 package and interface have been defined to match a multitude of hardware requirements. Since the sensor has a flat, small footprint package it is attractive for mobile applications. The sensor can be programmed to optimize functionality, performance and power consumption in customer specific applications.

Key features BMA150

- ▶ Switchable g-range and bandwidth
- ▶ Low-power consumption
- ▶ SPI (3-wire/4-wire) and I²C interfaces
- ▶ Programmable interrupt feature for mobile wake-up or free-fall detection
- ▶ Ultra-low-power self-wake-up mode
- ▶ Self-test capability
- ▶ Absolute temperature output
- ▶ LGA package (footprint 3mm x 3mm, height 0.9mm)
- ▶ RoHS compliant

The BMA150 senses tilt, motion, and vibration in cell phones, handhelds, computer peripherals, man-machine interfaces, virtual reality features and game controllers.

BMA150 target applications

- ▶ Advanced power management for mobile devices
- ▶ HDD protection
- ▶ Drop detection for warranty logging
- ▶ Menu scrolling, tip-tap function
- ▶ Step-counting
- ▶ Display profile switching (portrait/landscape)
- ▶ Detection
- ▶ Gaming

Technical data	BMA150
Sensitivity axes	x/y/z
Measurement range	±2g, ±4g, ±8g (switchable via SPI/I ² C)
Sensitivity (calibrated)	2g: 256LSB/g 4g: 128LSB/g 8g: 64LSB/g
Resolution	10bit → 4mg (±2g range)
Nonlinearity	±0.5% FS
Axes mixing	2%
Zero-g offset (calibrated)	±60mg
Zero-g offset temperature drift	1mg/K
Noise	0.5mg/√Hz
Bandwidth	25Hz ... 1500Hz (switchable via SPI/I ² C)
Digital input / output	SPI & I ² C, Interrupt pin
Supply voltage	2.4 ... 3.6V, 1.62 ... 3.6V IO
Current consumption	200μA
Idle current	1μA
Wake-up time	1ms
Temperature range	-40°C ... +85°C

Pin configuration for SPI interface (bottom view)

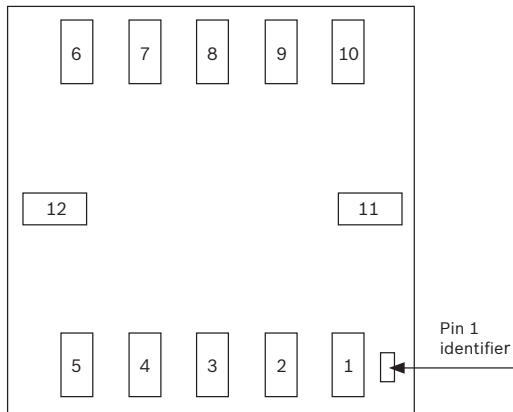

Pin No.	Name	Function
1	Reserved	Do not connect
2	VDD	Analog power supply
3	GND	Ground
4	INT	Interrupt
5	CSB	Chip select
6	SCK	Serial clock
7	SDO	Serial data output
8	SDI	Serial data in/out
9	VDDIO	Digital interface power supply
10	Reserved	Do not connect
11	Reserved	Do not connect
12	Reserved	Do not connect

Sensor operation

The function and performance of the BMA150 can be programmed to match customer specific applications by means of parameter and control settings.

The BMA150 provides a digital 10bit output signal in SPI or I²C format. Via serial interface command the full measurement range can be chosen to $\pm 2g$, $\pm 4g$ or $\pm 8g$. A second-order filter with a pole-frequency of 1500Hz is included to provide preconditioning of the measured acceleration signal. The maximum data conversion rate is 3KHz.

Additional digital filtering is possible to improve S/N ratio (down to 25Hz bandwidth). Typical noise level and quantization lead to a resolution of 4mg.

The current consumption is typically 200 μ A at a supply voltage of 2.5V. In addition there are several features implemented to support the host system in reducing power consumption.

Parallel to normal operation where acceleration values are provided to the output registers the BMA150 is capable to perform internal computations of the results. The customer is enabled to define specific criteria, e.g. high-g or low-g thresholds but also criteria for the recognition of smooth motion profiles. The sensor can inform the host system about the violation of one of these criteria via an interrupt pin. This feature can be used for many purposes, e.g. to wake-up the host system from a global sleep mode, to signalise a shock situation or to indicate free fall.

The BMA150 also features self-test capability. Thus, it allows for testing of the complete signal evaluation path including the micromachined sensor structure and the evaluation ASIC.

The sensor comes in a land-grid array (LGA) type package with a footprint of 3mm x 3mm and a height of merely 0.9mm.

Please contact us for further details. We are happy to provide more information.

Headquarters Bosch Sensortec GmbH

Gerhard-Kindler-Strasse 8
72770 Reutlingen · Germany
Telephone +49 7121 3535 900
Fax +49 7121 3535 909
contact@bosch-sensortec.com
www.bosch-sensortec.com