

FEATURES

- 3.8 mm × 5.0 mm × 0.9 mm module with integrated optical components**
- 2 green LEDs, 2 PDs with IR cut filter**
- 2 external sensor inputs**
- 3, 370 mA LED drivers**
- 20-bit burst accumulator enabling 20 bits per sample period**
- On-board sample to sample accumulator enabling up to 27 bits per data read**
- Custom optical package made to work under a glass window**
- Optimized SNR for signal limited cases**
- I²C or SPI communications**

APPLICATIONS

- Optical heart rate monitoring**
- Reflective SpO₂ measurement**
- CNIBP measurement**

GENERAL DESCRIPTION

The ADPD188GG is a complete photometric system designed to measure optical signals from ambient light and from synchronous reflected light emitting diode (LED) pulses. Synchronous measurement offers best-in-class rejection of ambient light interference, both dc and ac. The module integrates a highly efficient photometric front end, two LEDs, and two photodiode (PD). All of these items are housed in a custom package that prevents light from going directly from the LED to the photodiode without first entering the subject.

The front end of the application specific integrated circuit (ASIC) consists of a control block, a 14-bit analog-to-digital converter (ADC) with a 20-bit burst accumulator, and three flexible, independently configurable LED drivers. The control circuitry includes flexible LED signaling and synchronous detection. The analog front end (AFE) features best-in-class rejection of signal offset and corruption due to modulated interference commonly caused by ambient light. The data output and functional configuration occur over a 1.8 V I²C interface or a serial peripheral interface (SPI) port.

FUNCTIONAL BLOCK DIAGRAM

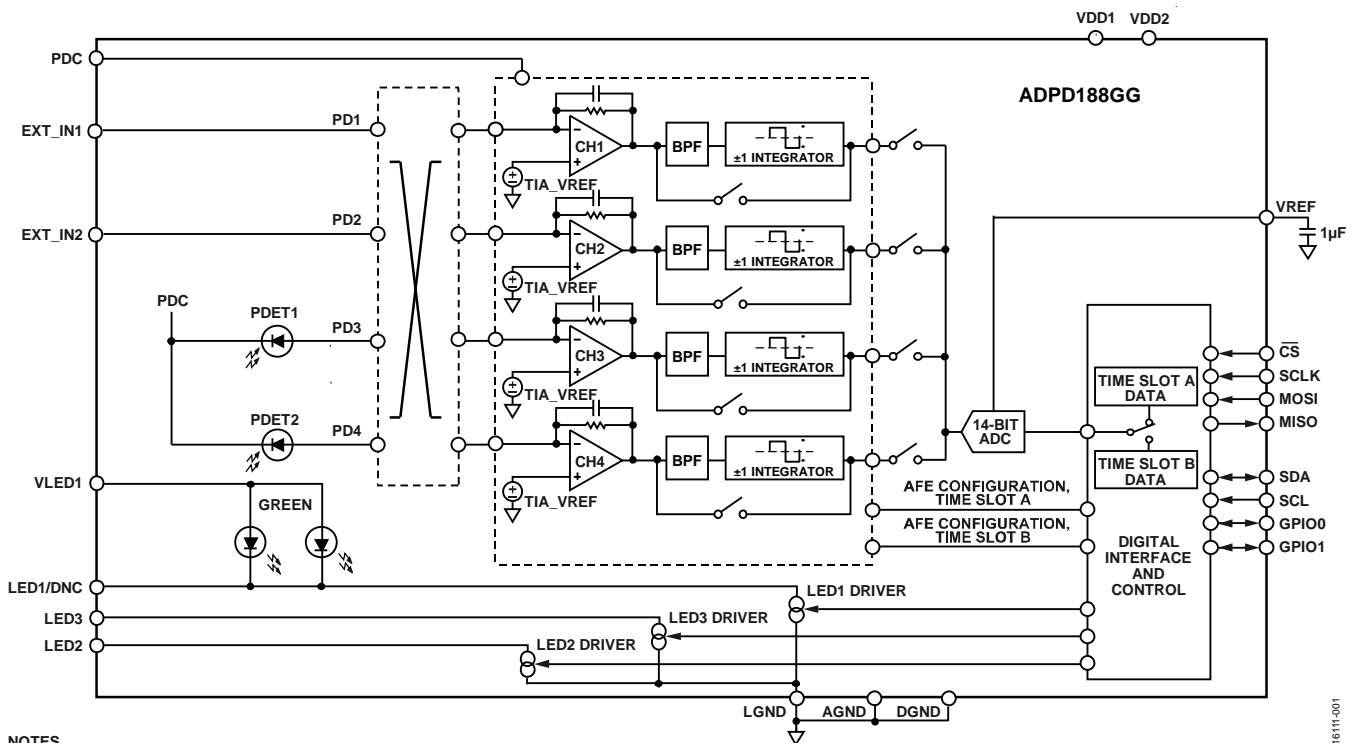

NOTES
1. DNC = DO NOT CONNECT. DO NOT CONNECT TO THIS PIN WHEN USING INTERNAL LEDs.

Figure 1.

Rev. A

[Document Feedback](#)

Information furnished by Analog Devices is believed to be accurate and reliable. However, no responsibility is assumed by Analog Devices for its use, nor for any infringements of patents or other rights of third parties that may result from its use. Specifications subject to change without notice. No license is granted by implication or otherwise under any patent or patent rights of Analog Devices. Trademarks and registered trademarks are the property of their respective owners.

One Technology Way, P.O. Box 9106, Norwood, MA 02062-9106, U.S.A.
Tel: 781.329.4700 ©2018 Analog Devices, Inc. All rights reserved.
[Technical Support](#) www.analog.com

TABLE OF CONTENTS

Features	1	Typical Connection Diagram	22
Applications	1	Land Pattern	22
General Description	1	Recommended Start-Up Sequence	23
Functional Block Diagram	1	Reading Data	23
Revision History	2	Clocks and Timing Calibration	24
Specifications	3	Optional Timing Signals Available on GPIO0 and GPIO1 ..	25
Analog Specifications	5	LED Driver Pins and LED Supply Voltage	26
Digital Specifications	6	LED Driver Operation	26
Timing Specifications	7	Determining the Average Current	27
Absolute Maximum Ratings	9	Determining C_{VLED}	27
Thermal Resistance	9	Using External LEDs	28
Recommended Soldering Profile	9	Calculating Current Consumption	28
ESD Caution	9	Mechanical Considerations for Covering the ADPD188GG ...	30
Pin Configuration and Function Descriptions	10	TIA ADC Mode	30
Typical Performance Characteristics	11	Pulse Connect Mode	33
Theory of Operation	13	Synchronous ECG and PPG Measurement Using TIA ADC Mode	34
Introduction	13	Float Mode	35
Optical Components	13	Register Listing	42
Dual Time Slot Operation	14	LED Control Registers	46
Time Slot Switch	15	AFE Configuration Registers	48
Adjustable Sampling Frequency	16	Float Mode Registers	52
External Synchronization for Sampling	16	System Registers	54
State Machine Operation	16	ADC Registers	59
Normal Mode Operation and Data Flow	17	Data Registers	60
Communications Interface	19	Outline Dimensions	61
I ² C Interface	19	Ordering Guide	61
SPI Port	20		
Applications Information	22	Changes to Table 26	42
		Changes to Table 29	50
		Changes to Table 30	51
		Changes to Address 0x58 Description Column, Table 31	53

REVISION HISTORY

10/2018—Rev. 0 to Rev. A

Changes to Figure 24 and Figure 25	22
Changes to Calibrating the 32 kHz Clock Section	25
Added Improving SNR Using Integrator Chopping Section and Figure 32; Renumbered Sequentially	29
Added Table 18; Renumbered Sequentially	30
Changes to Table 26	42
Changes to Table 29	50
Changes to Table 30	51
Changes to Address 0x58 Description Column, Table 31	53

2/2018—Revision 0: Initial Version

SPECIFICATIONS

The voltage applied at the VDD1 and VDD2 pins (V_{DD}) = 1.8 V, and T_A = full operating temperature range, unless otherwise noted.

Table 1.

Parameter	Test Conditions/Comments	Min	Typ	Max	Unit
CURRENT CONSUMPTION					
Peak V_{DD} Supply Current	See the Calculating Current Consumption section for the relevant equations Single-channel (Register 0x3C, Bits[8:3] = 0x38)		4.5		mA
V_{DD} Standby Current			0.3		μ A
Average V_{DD} Supply Current	100 Hz data rate; LED offset = 25 μ s; LED pulse period (t_{LED_PERIOD}) = 13 μ s; LED peak current = 25 mA				
1 Pulse	Time Slot A only		53		μ A
	Time Slot B only		41		μ A
	Both Time Slot A and Time Slot B		76		μ A
10 Pulses	Time Slot A only		107		μ A
	Time Slot B only		95		μ A
	Both Time Slot A and Time Slot B		184		μ A
Average V_{LED} Supply Current	LED peak current = 25 mA				
1 Pulse	50 Hz data rate		3.75		μ A
	100 Hz data rate		7.5		μ A
	200 Hz data rate		15		μ A
10 Pulses	50 Hz data rate		38		μ A
	100 Hz data rate		75		μ A
	200 Hz data rate		150		μ A
SATURATION ILLUMINANCE¹					
Direct Illumination	Blackbody color temperature ($T = 5500$ K) ² , PDET1 and PDET2 multiplexed into a single channel (1.2 mm ² active area) Transimpedance amplifier (TIA) gain = 25 k Ω TIA gain = 50 k Ω TIA gain = 100 k Ω TIA gain = 200 k Ω		58.8 29.4 14.7 7.4		kLux kLux kLux kLux
DATA ACQUISITION					
ADC Resolution	Single pulse		14		Bits
Per Sample	64 pulses to 255 pulses		20		Bits
Per Data Read	64 pulses to 255 pulses; 128 samples averaged		27		Bits
LED PERIOD					
	AFE width = 4 μ s ³	13	19		μ s
	AFE width = 3 μ s	11	17		μ s
Sampling Frequency ⁴	Time Slot A or Time Slot B; normal mode; 1 pulse; SLOTA_LED_OFFSET = 23 μ s; SLOTA_PERIOD = 19 μ s	0.122		2000	Hz
	Both time slots; normal mode; 1 pulse; SLOTA_LED_OFFSET = 23 μ s; SLOTA_PERIOD = 19 μ s	0.122		1600	Hz
	Time Slot A or Time Slot B; normal mode; 8 pulses; SLOTA_LED_OFFSET = 23 μ s; SLOTA_PERIOD = 19 μ s	0.122		1600	Hz
	Both time slots; normal mode; 8 pulses; SLOTA_LED_OFFSET = 23 μ s; SLOTA_PERIOD = 19 μ s	0.122		1000	Hz

Parameter	Test Conditions/Comments	Min	Typ	Max	Unit
CATHODE PIN (PDC) VOLTAGE					
During All Sampling Periods	Register 0x54, Bit 7 = 0x0; Register 0x3C, Bit 9 = 1 ⁵		1.8		V
	Register 0x54, Bit 7 = 0x0; Register 0x3C, Bit 9 = 0		1.3		V
During Time Slot A Sampling	Register 0x54, Bit 7 = 0x1; Register 0x54, Bits[9:8] = 0x0 ⁵		1.8		V
	Register 0x54, Bit 7 = 0x1; Register 0x54, Bits[9:8] = 0x1		1.3		V
	Register 0x54, Bit 7 = 0x1; Register 0x54, Bits[9:8] = 0x2		TIA_VREF + 0.25		V
During Time Slot B Sampling	Register 0x54, Bit 7 = 0x1; Register 0x54, Bits[9:8] = 0x3 ⁶		0		V
	Register 0x54, Bit 7 = 0x1; Register 0x54, Bits[11:10] = 0x0 ⁵		1.8		V
	Register 0x54, Bit 7 = 0x1; Register 0x54, Bits[11:10] = 0x1		1.3		V
	Register 0x54, Bit 7 = 0x1; Register 0x54, Bits[11:10] = 0x2		TIA_VREF + 0.25		V
During Sleep Periods	Register 0x54, Bit 7 = 0x1; Register 0x54, Bits[11:10] = 0x3 ⁶		0		V
	Register 0x54, Bit 7 = 0x0; Register 0x3C, Bit 9 = 1		1.8		V
	Register 0x54, Bit 7 = 0x0; Register 0x3C, Bit 9 = 0		1.3		V
	Register 0x54, Bit 7 = 0x1; Register 0x54, Bits[13:12] = 0x0		1.8		V
	Register 0x54, Bit 7 = 0x1; Register 0x54, Bits[13:12] = 0x1		1.3		V
	Register 0x54, Bit 7 = 0x1; Register 0x54, Bits[13:12] = 0x2		TIA_VREF + 0.25		V
	Register 0x54, Bit 7 = 0x1; Register 0x54, Bits[13:12] = 0x3		0		V
LEDs					
LED Peak Current Setting	Adjustable via the Register 0x22 through Register 0x25 settings	12		370	mA
Dominant Wavelength ⁷			525		nm
LED1; Green LED	I _F = 40 mA				
Luminous Intensity	λ = 525 nm, I _F = 40 mA at 25°C	2800		3200	mcd
Photodiode					
Responsivity	Wavelength, λ = 525 nm		0.25		A/W
Active Area					
Photodiode 1			0.4		mm ²
Photodiode 2			0.8		mm ²
POWER SUPPLY VOLTAGES	The ADPD188GG does not require a specific power-up sequence Applied at the VDD1 and VDD2 pins	1.7	1.8	1.9	V
V _{DD}					
V _{LED1} ^{8,9}		4	4.5	5.0	V
DC Power Supply Rejection Ratio (PSRR)	At 75% full scale input signal		24		dB
TEMPERATURE RANGE					
Operating		-40		+85	°C

¹ Saturation illuminance refers to the amount of ambient light that saturates the ADPD188GG signal. Actual results may vary by factors of up to 2× from typical specifications. As a point of reference, Air Mass 1.5 (AM1.5) sunlight (brightest sunlight) produces 100 kLux.

² Blackbody color temperature (T = 5800 K) closely matches the light produced by solar radiation (sunlight).

³ Minimum LED period = (2 × AFE width) + 5 μs.

⁴ The maximum values in this specification are the internal ADC sampling rates in normal mode. The I²C read rates in some configurations may limit the output data rate.

⁵ This mode may induce additional noise and is not recommended unless necessary. The 1.8 V setting uses V_{DD}, which contains greater amounts of differential voltage noise with respect to the anode voltage. A differential voltage between the anode and cathode injects a differential current across the capacitance of the photodiode of the magnitude of C × dV/dt.

⁶ This setting is not recommended for photodiodes because it causes a 1.3 V forward bias of the photodiode.

⁷ I_F is the forward current of the diode.

⁸ Set V_{LEDx} such that the maximum desired LED current is achievable with the turn on voltage of the LEDs that are wired to the LEDx/DNC pins. The LEDx/DNC pins are connected to the LEDx driver, which can be modeled as current sinks (see Figure 1). When an appropriate V_{LEDx} is used, the voltage at the LEDx/DNC pins adjusts automatically to accommodate the LED turn on voltage and the LED current.

⁹ See Figure 9 for the current limitation at the minimum V_{LED} supply voltage, V_{LED}.

ANALOG SPECIFICATIONS

VDD1 = VDD2 = 1.8 V, and T_A = full operating temperature range, unless otherwise noted.

Table 2.

Parameter	Test Conditions/Comments	Min	Typ	Max	Unit
EXT_INx SERIES RESISTANCE (R_IN) ¹	Measured from -3 μA to +3 μA		6.5		kΩ
PULSED SIGNAL CONVERSIONS, 3 μs WIDE LED PULSE ² ADC Resolution ³	4 μs wide AFE integration; normal operation, Register 0x43 and Register 0x45 = 0xADA5 TIA feedback resistor 25 kΩ 50 kΩ 100 kΩ 200 kΩ				
			3.27		nA/LSB
			1.64		nA/LSB
			0.82		nA/LSB
			0.41		nA/LSB
ADC Saturation Level	TIA feedback resistor 25 kΩ 50 kΩ 100 kΩ 200 kΩ				
			26.8		μA
			13.4		μA
			6.7		μA
			3.35		μA
Ambient Signal Headroom on Pulsed Signal	TIA feedback resistor 25 kΩ 50 kΩ 100 kΩ 200 kΩ				
			23.6		μA
			11.8		μA
			5.9		μA
			2.95		μA
PULSED SIGNAL CONVERSIONS, 2 μs WIDE LED PULSE ² ADC Resolution ³	3 μs wide AFE integration; normal operation, Register 0x43 and Register 0x45 = 0xADA5 TIA feedback resistor 25 kΩ 50 kΩ 100 kΩ 200 kΩ				
			4.62		nA/LSB
			2.31		nA/LSB
			1.15		nA/LSB
			0.58		nA/LSB
ADC Saturation Level	TIA feedback resistor 25 kΩ 50 kΩ 100 kΩ 200 kΩ				
			37.84		μA
			18.92		μA
			9.46		μA
			4.73		μA
Ambient Signal Headroom on Pulsed Signal	TIA feedback resistor 25 kΩ 50 kΩ 100 kΩ 200 kΩ				
			12.56		μA
			6.28		μA
			3.14		μA
			1.57		μA
FULL SIGNAL CONVERSIONS ⁴ TIA Saturation Level Pulsed Signal and Ambient Level	TIA feedback resistor 25 kΩ 50 kΩ 100 kΩ 200 kΩ				
			50.4		μA
			25.2		μA
			12.6		μA
			6.3		μA
TIA Linear Range	TIA feedback resistor 25 kΩ 50 kΩ 100 kΩ 200 kΩ				
			42.8		μA
			21.4		μA
			10.7		μA
			5.4		μA

Parameter	Test Conditions/Comments	Min	Typ	Max	Unit
SYSTEM PERFORMANCE					
Total Output Noise Floor	Normal mode; per pulse; per channel; no LED; photodiode capacitance (C_{PD}) = 25 pF				
	25 k Ω ; referred to ADC input		1.0		LSB rms
	25 k Ω ; referred to peak input signal for 2 μ s LED pulse		4.6		nA rms
	25 k Ω ; referred to peak input signal for 3 μ s LED pulse		3.3		nA rms
	25 k Ω ; saturation signal-to-noise ratio (SNR) per pulse per channel ⁵		78.3		dB
	50 k Ω ; referred to ADC input		1.1		LSB rms
	50 k Ω ; referred to peak input signal for 2 μ s LED pulse		2.5		nA rms
	50 k Ω ; referred to peak input signal for 3 μ s LED pulse		1.8		nA rms
	50 k Ω ; saturation SNR per pulse per channel ⁵		77.4		dB
	100 k Ω ; referred to ADC input		1.2		LSB rms
	100 k Ω ; referred to peak input signal for 2 μ s LED pulse		1.4		nA rms
	100 k Ω ; referred to peak input signal for 3 μ s LED pulse		0.98		nA rms
	100 k Ω ; saturation SNR per pulse per channel ⁵		76.7		dB
	200 k Ω ; referred to ADC input		1.4		LSB rms
	200 k Ω ; referred to peak input signal for 2 μ s LED pulse		0.81		nA rms
	200 k Ω ; referred to peak input signal for 3 μ s LED pulse		0.57		nA rms
200 k Ω ; saturation SNR per pulse per channel ⁵		75.3		dB	

¹ The R_{IN} value can be ignored for current source inputs or for PD inputs. This value is important for calculating correct voltages for voltage inputs through a resistor.

² This saturation level applies to the ADC only and, therefore, includes only the pulsed signal. Any nonpulsatile signal is removed prior to the ADC stage.

³ ADC resolution is listed per pulse. If using multiple pulses, divide by the number of pulses.

⁴ This saturation level applies to the full signal path and, therefore, includes both the ambient signal and the pulsed signal.

⁵ The noise term of the saturation SNR value refers to the receive noise only and does not include photon shot noise or any noise on the LED signal itself.

DIGITAL SPECIFICATIONS

VDD1 = VDD2 = 1.7 V to 1.9 V, unless otherwise noted.

Table 3.

Parameter	Symbol	Test Conditions/Comments	Min	Typ	Max	Unit
LOGIC INPUTS						
Input Voltage Level						
High	V_{IH}	GPIOx, SCLK, MOSI, \overline{CS} SCL, SDA	$0.7 \times VDDx$		$VDDx$	V
High	V_{IH}		$0.7 \times VDDx$		3.6	
Low	V_{IL}				$0.3 \times VDDx$	V
Input Current Level						
High	I_{IH}		-10		+10	μ A
Low	I_{IL}		-10		+10	μ A
Input Capacitance	C_{IN}			10		pF
LOGIC OUTPUTS						
Output Voltage Level						
High	V_{OH}	GPIOx, MISO	$VDDx - 0.5$			V
Low	V_{OL}				0.5	V
Output Voltage Level						
Low	V_{OL1}	SDA			$0.2 \times VDDx$	V
Output Current Level						
Low	I_{OL}	SDA $V_{OL1} = 0.6 V$	6			mA

TIMING SPECIFICATIONS

I²C Timing Specifications

Table 4.

Parameter	Symbol	Min	Typ	Max	Unit
SCL					
Frequency			1		Mb/sec
Minimum Pulse Width					
High	t ₁	370			ns
Low	t ₂	530			ns
START CONDITION					
Hold Time	t ₃	260			ns
Setup Time	t ₄	260			ns
SDA SETUP TIME	t ₅	50			ns
SCL AND SDA					
Rise Time	t ₆			120	ns
Fall Time	t ₇			120	ns
STOP CONDITION					
Setup Time	t ₈	260			ns

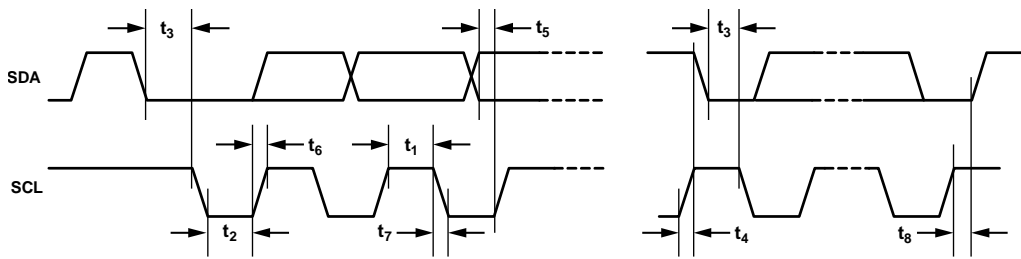

Figure 2. I²C Timing Diagram

1811-002

SPI Timing Specifications

Table 5.

Parameter	Symbol	Test Conditions/Comments	Min	Typ	Max	Unit
SCLK						
Frequency	f_{SCLK}				10	MHz
Minimum Pulse Width						
High	$t_{SCLKPWH}$		20			ns
Low	$t_{SCLKPWL}$		20			ns
\overline{CS}						
Setup Time	t_{CSS}	\overline{CS} setup to SCLK rising edge	10			ns
Hold Time	t_{CSH}	\overline{CS} hold from SCLK rising edge	10			ns
Pulse Width High	t_{CSPWH}	\overline{CS} pulse width high	10			ns
MOSI						
Setup Time	t_{MOSIS}	MOSI setup to SCLK rising edge	10			ns
Hold Time	t_{MOSIH}	MOSI hold from SCLK rising edge	10			ns
MISO OUTPUT DELAY	t_{MISOD}	MISO valid output delay from SCLK falling edge			21	ns

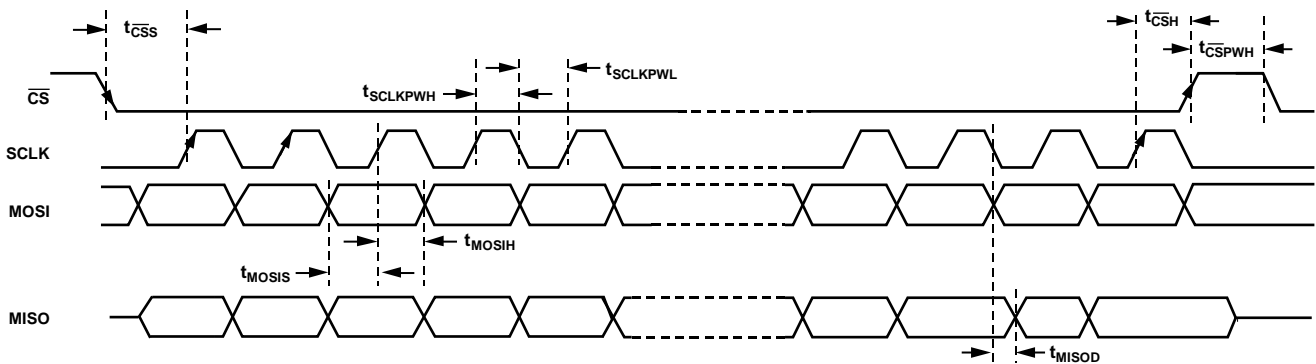

Figure 3. SPI Timing Diagram

1611-003

ABSOLUTE MAXIMUM RATINGS

Table 6.

Parameter	Rating
VDD1, VDD2 to AGND	-0.3 V to +2.2 V
VDD1, VDD2 to DGND	-0.3 V to +2.2 V
EXT_IN1/EXT_IN2	-0.3 V to +2.2 V
GPIO0/GPIO1 to DGND	-0.3 V to +2.2 V
MISO/MOSI/SCLK/ \overline{CS} to DGND	-0.3 V to +2.2 V
LEDx/DNC to LGND	-0.3 V to +3.6 V
SCL/SDA to DGND	-0.3 V to +3.6 V
VLEDx to LGND ¹	-0.3 V to +5.0 V
Electrostatic Discharge (ESD)	
Human Body Model (HBM)	3000 V
Charged Device Model (CDM)	1250 V
Machine Model (MM)	100 V
Solder Reflow (Pb-Free)	
Peak Temperature	260 (+0/-5)°C
Time at Peak Temperature	<30 sec
Temperature Range	
Powered	-40°C to +85°C
Storage	-40°C to +105°C
Junction Temperature	105°C

¹ The absolute maximum voltage allowable between VLEDx and LGND is the voltage that causes the LEDx/DNC pins to reach or exceed their absolute maximum voltage.

Stresses at or above those listed under Absolute Maximum Ratings may cause permanent damage to the product. This is a stress rating only; functional operation of the product at these or any other conditions above those indicated in the operational section of this specification is not implied. Operation beyond the maximum operating conditions for extended periods may affect product reliability.

THERMAL RESISTANCE

Thermal performance is directly linked to printed circuit board (PCB) design and operating environment. Careful attention to PCB thermal design is required.

Table 7. Thermal Resistance

Package Type ¹	Supply Pins	θ_{JA}	Unit
CE-24-1			
ASIC	VDD1, VDD2	67	°C/W
LED1	VLED1	156	°C/W

¹ Thermal impedance simulated values are based on JEDEC 252P and two thermal vias. See JEDEC JESD51.

RECOMMENDED SOLDERING PROFILE

Figure 4 and Table 8 provide details about the recommended soldering profile.

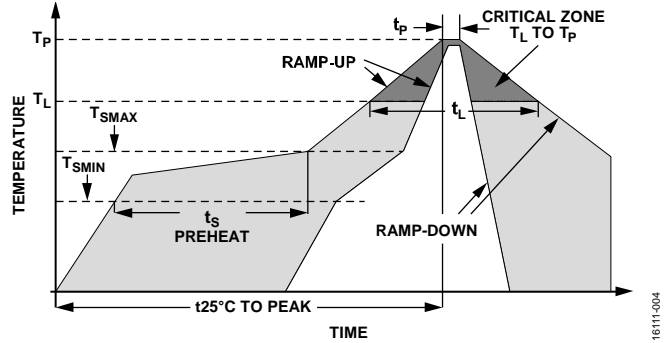

Figure 4. Recommended Soldering Profile

Table 8. Recommended Soldering Profile

Profile Feature	Condition (Pb-Free)
Average Ramp Rate (T_L to T_P)	2°C/sec max
Preheat	
Minimum Temperature (T_{SMIN})	150°C
Maximum Temperature (T_{SMAX})	200°C
Time, T_{SMIN} to T_{SMAX} (t_S)	60 sec to 120 sec
T_{SMAX} to T_L Ramp-Up Rate	2°C/sec max
Time Maintained Above Liquidous Temperature	
Liquidous Temperature (T_L)	217°C
Time (t_L)	60 sec to 150 sec
Peak Temperature (T_P)	260 (+0/-5)°C
Time Within 5°C of Actual Peak Temperature (t_P)	<30 sec
Ramp-Down Rate	3°C/sec max
Time 25°C to Peak Temperature	8 minutes max

ESD CAUTION



ESD (electrostatic discharge) sensitive device. Charged devices and circuit boards can discharge without detection. Although this product features patented or proprietary protection circuitry, damage may occur on devices subjected to high energy ESD. Therefore, proper ESD precautions should be taken to avoid performance degradation or loss of functionality.

PIN CONFIGURATION AND FUNCTION DESCRIPTIONS

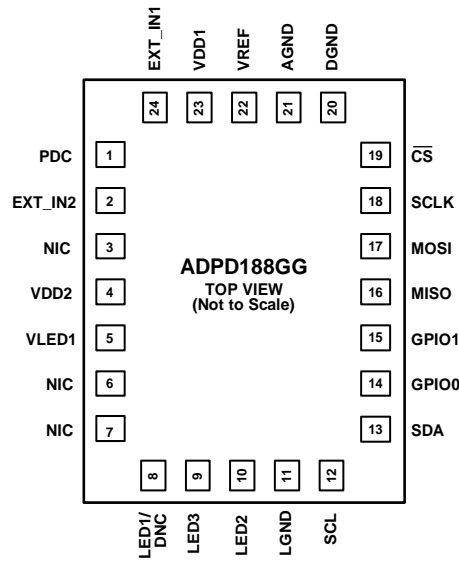

NOTES

1. DNC = DO NOT CONNECT. DO NOT CONNECT TO THIS PIN WHEN USING INTERNAL LEDs.
2. NIC = NO INTERNAL CONNECTION.

18111-005

Figure 5. Pin Configuration

Table 9. Pin Function Descriptions

Pin No.	Mnemonic	Type ¹	Description
1	PDC	AO	Photodiode Common Cathode Bias.
2	EXT_IN2	AI	EXT_IN2 Current Input.
3	NIC	NIC	No Internal Connection. This pin is not internally connected.
4	VDD2	S	1.8 V Supply.
5	VLED1	S	Green LED Anode Supply Voltage.
6	NIC	NIC	No Internal Connection. This pin is not internally connected.
7	NIC	NIC	No Internal Connection. This pin is not internally connected.
8	LED1/DNC	AO/DNC	LED1 Driver Current Sink (LED1)/Do Not Connect (DNC). Do not connect to this pin when using internal LEDs.
9	LED3	AO	LED3 Driver Current Sink. If not in use, leave this pin floating.
10	LED2	AO	LED2 Driver Current Sink. If not in use, leave this pin floating.
11	LGND	S	LED Driver Ground.
12	SCL	DI	I ² C Clock Input.
13	SDA	DO	I ² C Data Output.
14	GPIO0	DIO	General-Purpose Input/Output 0.
15	GPIO1	DIO	General-Purpose Input/Output 1.
16	MISO	DO	SPI Master Input, Slave Output.
17	MOSI	DI	SPI Master Output, Slave Input.
18	SCLK	DI	SPI Clock Input.
19	\overline{CS}	DI	SPI Chip Select (Active Low).
20	DGND	S	Digital Ground.
21	AGND	S	Analog Ground.
22	VREF	REF	Internally Generated ADC Voltage Reference. Connect a 1 μ F ceramic capacitor from VREF to ground.
23	VDD1	S	1.8 V Supply.
24	EXT_IN1	AI	EXT_IN1 Current Input.

¹ AO is analog output, AI is analog input, NIC is not internally connected, S is supply, DNC is do not connect, DI is digital input, DO is digital output, DIO is digital input/output, and REF is analog reference.

TYPICAL PERFORMANCE CHARACTERISTICS

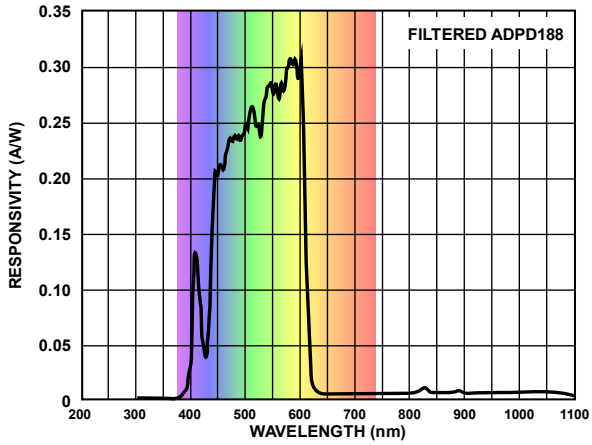

Figure 6. Typical Photodiode Responsivity

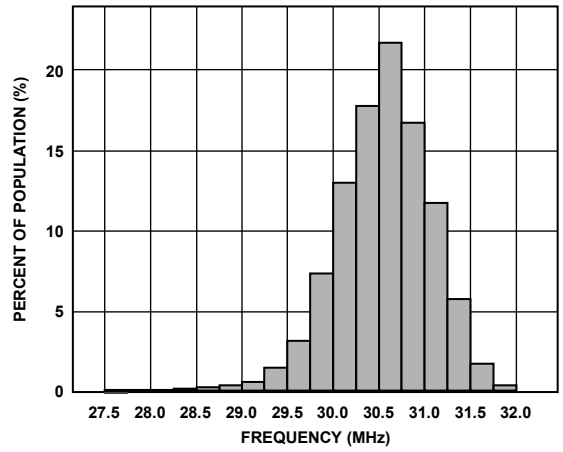

Figure 8. 32 MHz Clock Frequency Distribution; Default Settings; Before User Calibration, Register 0x4D = 0x425E

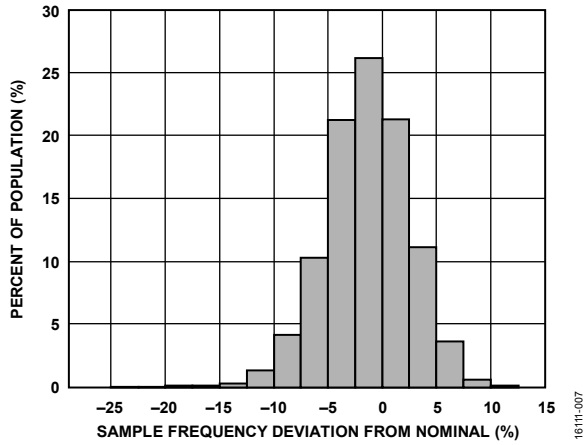

Figure 7. 32 kHz Clock Frequency Distribution; Default Settings; Before User Calibration, Register 0x4B = 0x2612

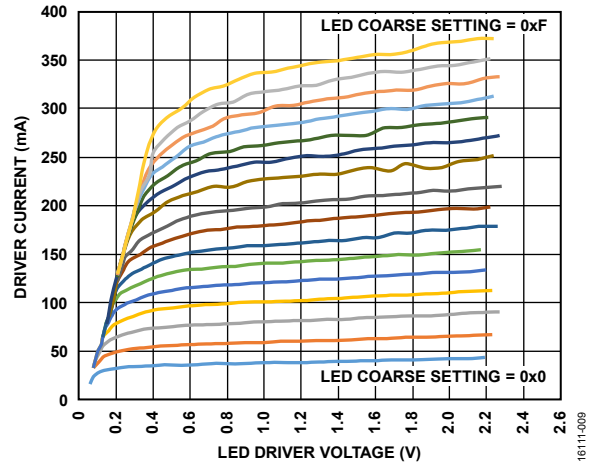

Figure 9. LED Driver Current vs. LED Driver Voltage at Various Coarse Settings

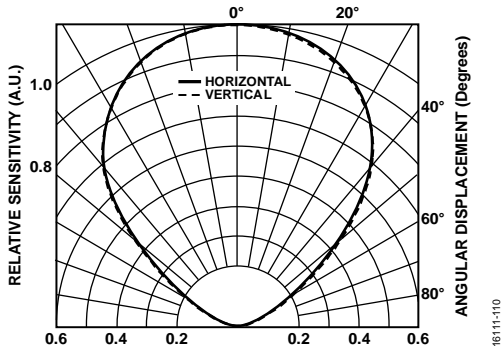

Figure 10. PD1 Relative Sensitivity vs. Angular Displacement

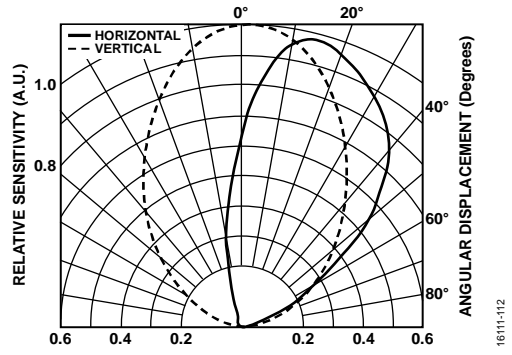

Figure 12. LED Relative Intensity vs. Angular Displacement

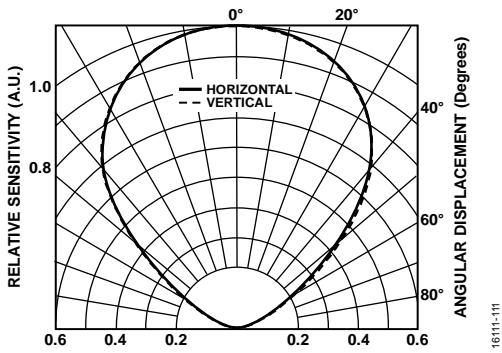

Figure 11. PD2 Relative Sensitivity vs. Angular Displacement

THEORY OF OPERATION

INTRODUCTION

The ADPD188GG is a complete, integrated, optical module designed for photoplethysmography (PPG) measurements. The module contains two optical detectors. Photodiode 1 (PDET1) has 0.4 mm² of active area and is connected to Channel 3 of the ASIC. Photodiode 2 (PDET2) has 0.8 mm² of active area and is connected to Channel 4 of the ASIC. The two photodiodes can be combined into a single detector with 1.2 mm² of active area. Both photo-diodes are coated with an infrared (IR) cut filter that maximizes ambient light rejection without the need for other light cancellation techniques.

The module combines the dual photodetector with two green LEDs, and a mixed-signal, photometric, front-end ASIC into a single compact device for optical measurements. The on-board ASIC includes an analog signal processing block, an ADC, a digital signal processing block, an I²C and SPI communication interface, and three, independently programmable, pulsed LED current sources.

The core circuitry stimulates the LEDs and measures the corresponding optical return signals in discrete data locations. Data can be read from output registers directly or through a first in, first out (FIFO) buffer.

This highly integrated system works well in environments where ambient light is poorly controlled and the signal modulation ratio is low. As a result, the device produces high SNR for relatively low LED power.

OPTICAL COMPONENTS

Photodiode

The ADPD188GG integrates a 1.2 mm² deep junction photodiode. The optical sensing area is a dual detector that is connected to Channel PD3 and Channel PD4 in the ASIC. The photodiodes are accessible from Time Slot A or Time Slot B. The responsivity of the ADPD188GG photodiode is shown in Figure 6.

LEDs

The ADPD188GG module integrates two green LEDs.

Table 10. LED Dominant Wavelength

LED Color	Driver	Typical Wavelength (nm)
Green (2x)	LED1	525

In addition to the integrated LEDs, the ADPD188GG has the ability to drive external LEDs.

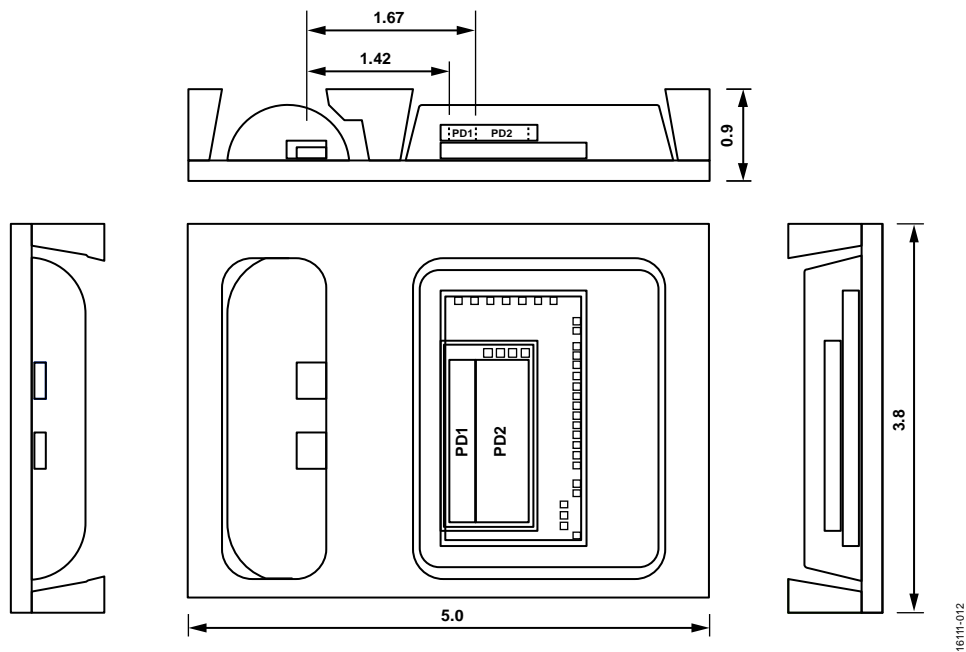

Figure 13. Optical Component Locations

DUAL TIME SLOT OPERATION

The ADPD188GG operates in two independent time slots, Time Slot A and Time Slot B, which are carried out sequentially. The entire signal path from LED stimulation to data capture and processing is executed during each time slot. Each time slot has a separate datapath that uses independent settings for the LED driver, AFE setup, and the resulting data. Time Slot A and Time Slot B operate in sequence for every sampling period, as shown in Figure 14.

The timing parameters in Figure 14 are defined as follows:

$$t_A (\mu s) = 25 + n_A \times 19$$

where n_A is the number of pulses for Time Slot A (Register 0x31, Bits[15:8]).

$$t_B (\mu s) = 25 + n_B \times 19$$

where n_B is the number of pulses for Time Slot B (Register 0x36, Bits[15:8]).

$t_1 = 68 \mu s$, the processing time for Time Slot A

$t_2 = 20 \mu s$, the processing time for Time Slot B

f_{SAMPLE} is the sampling frequency (Register 0x12, Bits[15:0]).

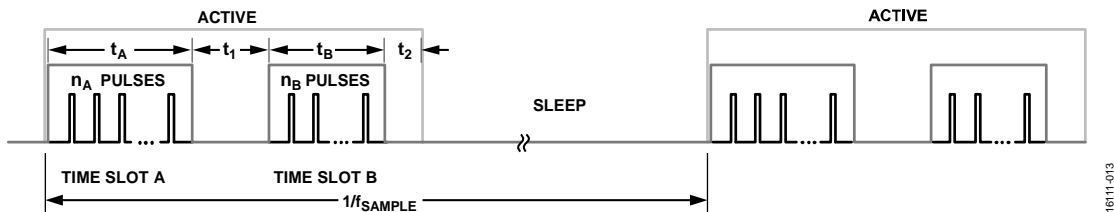

Figure 14. Time Slot Timing Diagram

Table 11. Recommended AFE and LED Timing Configuration

Register Name	Address		Recommended Setting
	Time Slot A	Time Slot B	
SLOTx_LEDMODE	0x30	0x35	0x0319
SLOTx_AFEMODE	0x39	0x3B	0x2209

TIME SLOT SWITCH

Multiple configurations of the four input channels are supported, depending on the settings of Register 0x14. The integrated photodiodes can either be routed to Channel 3 and Channel 4, or summed together into Channel 1. The external EXT_IN1 and EXT_IN2 inputs can be routed to Channel 1 and Channel 2, respectively, or summed into Channel 2. See Figure 15 and Figure 16 for the supported configurations. In Figure 15 and Figure 16, PDET1 is Photodiode 1, and PDET2 is Photodiode 2.

See Table 12 for the time slot switch registers. It is important to leave any unused inputs floating for proper operation of the devices. The photodiode inputs are current inputs and, as such, these pins are also considered to be voltage outputs. Tying these inputs to a voltage may saturate the analog block.

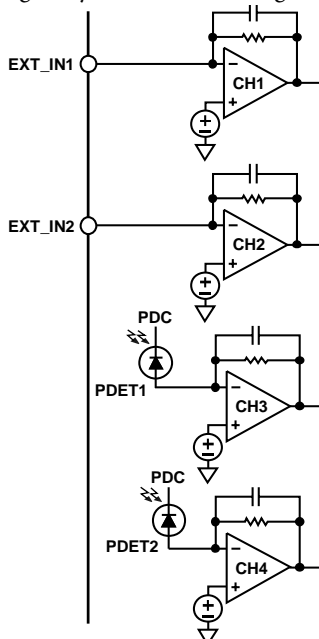

INPUT CONFIGURATION FOR
REGISTER 0x14[11:8] = 5
REGISTER 0x14[7:4] = 5

16111-014

Figure 15. PD1 to PD4 Connection

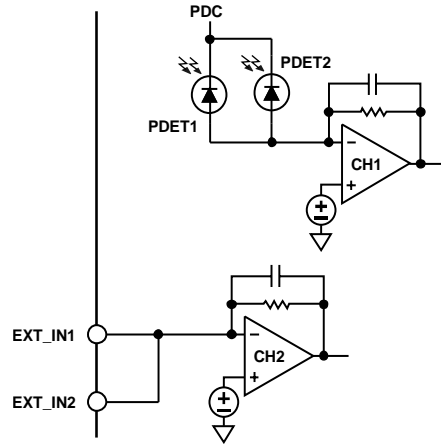

INPUT CONFIGURATION FOR
REGISTER 0x14[11:8] = 1
REGISTER 0x14[7:4] = 1

Figure 16. Current Summation

16111-015

Table 12. Time Slot Switch (Register 0x14)

Address	Bits	Name	Description
0x14	[11:8]	SLOTB_PD_SEL	These bits select the connection of input channels for Time Slot B as shown in Figure 15 and Figure 16. 0x0: inputs are floating in Time Slot B. 0x1: PDET1 and PDET2 are connected to Channel 1; EXT_IN1 and EXT_IN2 are connected to Channel 2 during Time Slot B. 0x5: EXT_IN1 is connected to Channel 1, EXT_IN2 is connected to Channel 2, PDET1 is connected to Channel 3, and PDET2 is connected to Channel 4 during Time Slot B. Other: reserved.
	[7:4]	SLOTA_PD_SEL	These bits select the connection of input channels for Time Slot A as shown in Figure 15 and Figure 16. 0x0: inputs are floating in Time Slot A. 0x1: PDET1 and PDET2 are connected to Channel 1; EXT_IN1 and EXT_IN2 are connected to Channel 2 during Time Slot A. 0x5: EXT_IN1 is connected to Channel 1, EXT_IN2 is connected to Channel 2, PDET1 is connected to Channel 3, and PDET2 is connected to Channel 4 during Time Slot A. Other: reserved.

ADJUSTABLE SAMPLING FREQUENCY

Register 0x12 controls the sampling frequency setting of the ADPD188GG and Register 0x4B, Bits[5:0] further tunes this clock for greater accuracy. The sampling frequency is governed by an internal 32 kHz sample rate clock that also drives the transition of the internal state machine. The maximum sampling frequencies for some sample conditions are listed in Table 1. The maximum sample frequency for all conditions, $f_{\text{SAMPLE_MAX}}$, is determined by the following equation:

$$f_{\text{SAMPLE_MAX}} = 1/(t_A + t_1 + t_B + t_2 + t_{\text{SLEEP_MIN}})$$

where $t_{\text{SLEEP_MIN}}$ is the minimum sleep time required between samples. See the Dual Time Slot Operation section for the definitions of t_A , t_1 , t_B , and t_2 .

If a given time slot is not in use, elements from that time slot do not factor into the calculation. For example, if Time Slot A is not in use, t_A and t_1 do not add to the sampling period and the new maximum sampling frequency is calculated as follows:

$$f_{\text{SAMPLE_MAX}} = 1/(t_B + t_2 + t_{\text{SLEEP_MIN}})$$

EXTERNAL SYNCHRONIZATION FOR SAMPLING

The ADPD188GG provides an option to use an external synchronization signal to trigger the sampling periods. This external sample synchronization signal can be provided either on the GPIO0 pin or the GPIO1 pin. This functionality is controlled by Register 0x4F, Bits[3:2]. When enabled, a rising edge on the selected input specifies when the next sample cycle occurs. When triggered, there is a delay of one to two internal sampling clock (32 kHz) cycles, and then the normal start-up sequence occurs. This sequence is the same as when the normal sample timer provides the trigger. To enable the external synchronization signal feature, use the following procedure:

1. Write 0x1 to Register 0x10 to enter program mode.
2. Write the appropriate value to Register 0x4F, Bits[3:2] to select whether the GPIO0 pin or the GPIO1 pin specifies when the next sample cycle occurs. Also, enable the appropriate input buffer using Register 0x4F, Bit 1, for the GPIO0 pin, or Register 0x4F, Bit 5, for the GPIO1 pin.
3. Write 0x4000 to Register 0x38.
4. Write 0x2 to Register 0x10 to start the sampling operations.
5. Apply the external synchronization signal on the selected pin at the desired rate; sampling occurs at that rate. As with normal sampling operations, read the data using the FIFO or the data registers. The maximum frequency constraints also apply in this case.

Providing an External 32 kHz Clock

The ADPD188GG has an option for the user to provide an external 32 kHz clock to the device for system synchronization or for situations where a clock with better accuracy than the internal 32 kHz clock is required. The external 32 kHz clock is provided on the GPIO1 pin only. To enable the 32 kHz external clock, use the following procedure at startup:

1. Drive the GPIO1 pin to a valid logic level or with the desired 32 kHz clock prior to enabling the GPIO1 pin as an input. Do not leave the pin floating prior to enabling it.
2. Write 0x1 to Register 0x4F, Bits[6:5] to enable the GPIO1 pin as an input.
3. Write 0x2 to Register 0x4B, Bits[8:7] to configure the devices to use an external 32 kHz clock. This setting disables the internal 32 kHz clock and enables the external 32 kHz clock.
4. Write 0x1 to Register 0x10 to enter program mode.
5. Write additional control registers in any order while the device is in program mode to configure the device as required.
6. Write 0x2 to Register 0x10 to start the normal sampling operation

STATE MACHINE OPERATION

During each time slot, the ADPD188GG operates according to a state machine. The state machine operates in the sequence shown in Figure 17.

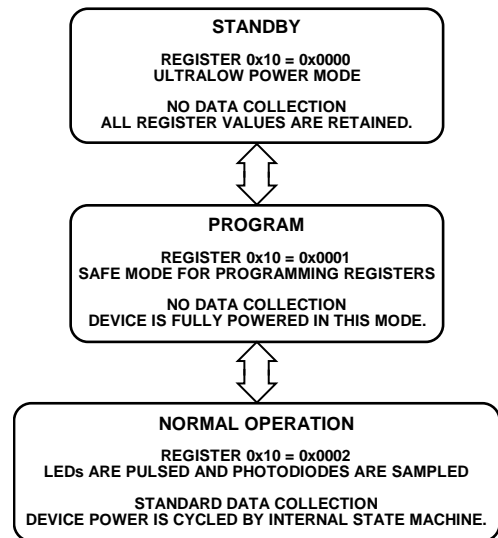

Figure 17. State Machine Operation Flowchart

18111-018

The ADPD188GG operates in one of three modes: standby, program, or normal sampling mode.

Standby mode is a power saving mode in which data collection does not occur. All register values are retained in this mode. To place the device in standby mode, write 0x0 to Register 0x10, Bits[1:0]. The device powers up in standby mode.

Program mode is used for programming registers. Always cycle the ADPD188GG through program mode when writing registers or changing modes. Because power cycling does not occur in this mode, the device may consume higher current in program mode than in normal operation. To place the device in program mode, write 0x1 to Register 0x10, Bits[1:0].

In normal operation, the ADPD188GG pulses light and collects data. Power consumption in this mode depends on the pulse count and data rate. To place the device in normal sampling mode, write 0x2 to Register 0x10, Bits[1:0].

NORMAL MODE OPERATION AND DATA FLOW

In normal mode, the ADPD188GG follows a specific pattern set up by the state machine. This pattern is shown in the corresponding data flow diagram in Figure 18. The pattern, in order, is as follows:

1. LED pulse and sample. The ADPD188GG pulses external LEDs. The response of the photodiode to the reflected light is measured by the ADPD188GG. Each data sample is constructed from the sum of n individual pulses, where n is user configurable between 1 and 255.
2. Intersample averaging. If desired, the logic can average n samples, from 2 to 128 in powers of 2, to produce output data. New output data is saved to the output registers every N samples.
3. Data read. The host processor reads the converted results from the data register or the FIFO.
4. Repeat. The sequence has a few different loops that enable different types of averaging while keeping both time slots close in time relative to each other.

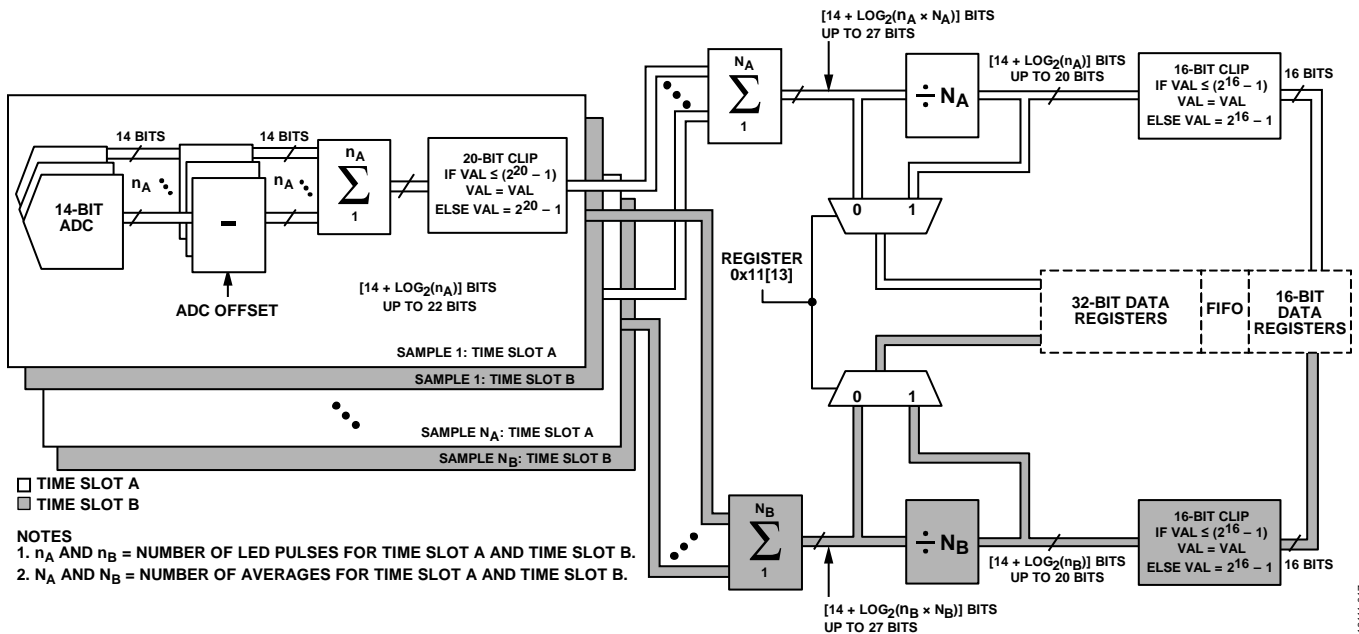

Figure 18. State Machine Operating Sequence (Datapath)

LED Pulse and Sample

At each sampling period, the selected LED driver drives a series of LED pulses, as shown in Figure 19. The magnitude, duration, and number of pulses are programmable over the communications interface. Each LED pulse coincides with a sensing period so that the sensed value represents the total charge acquired on the photodiode in response to only the corresponding LED pulse. Charge, such as ambient light that does not correspond to the LED pulse, is rejected.

After each LED pulse, the photodiode output relating to the pulsed LED signal is sampled and converted to a digital value by the 14-bit ADC. Each subsequent conversion within a sampling period is summed with the previous result. Up to 255 pulse values from the ADC can be summed in an individual sampling period. There is a 20-bit maximum range for each sampling period.

Averaging

The ADPD188GG offers sample accumulation and averaging functionality to increase signal resolution.

Within a sampling period, the AFE can sum up to 256 sequential pulses. As shown in Figure 18, samples acquired by the AFE are clipped to 20 bits at the output of the AFE. Additional resolution, up to 27 bits, can be achieved by averaging between sampling periods. This accumulated data of N samples is stored as 27-bit values and can be read out directly by using the 32-bit output registers or the 32-bit FIFO configuration.

When using the averaging feature set up by the register, subsequent pulses can be averaged by powers of 2. The user can select

from 2, 4, 8, ..., up to 128 samples to be averaged. Pulse data is still acquired by the AFE at the sampling frequency, f_{SAMPLE} (see Register 0x12), but new data is written to the registers at the rate of f_{SAMPLE}/N every N^{th} sample. This new data consists of the sum of the previous N samples. The full 32-bit sum is stored in the 32-bit registers. However, before sending this data to the FIFO, a divide by N operation occurs. This divide operation maintains bit depth to prevent clipping on the FIFO.

Use this between sample averaging to lower the noise while maintaining 16-bit resolution. If the pulse count registers are kept to 8 or less, the 16-bit width is never exceeded. Therefore, when using Register 0x15 to average subsequent pulses, many pulses can be accumulated without exceeding the 16-bit word width. This setting can reduce the number of FIFO reads required by the host processor.

Data Read

The host processor reads output data from the ADPD188GG via the communications interface, from the data registers, or from the FIFO. New output data is made available every N samples, where N is the user configured averaging factor. The averaging factors for Time Slot A and Time Slot B are configurable independently of each other. If the factors are the same, both time slots can be configured to save data to the FIFO. If the two averaging factors are different, only one time slot can save data to the FIFO; data from the other time slot can be read from the output registers.

The data read operations are described in more detail in the Reading Data section.

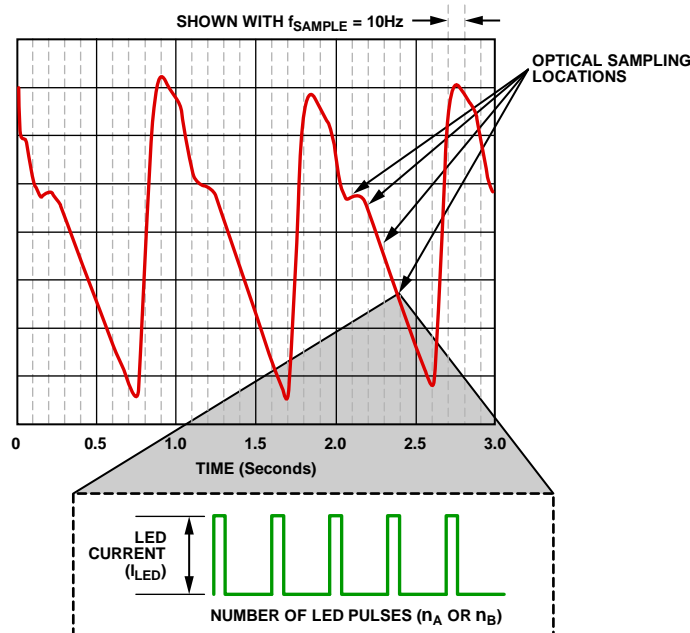

Figure 19. Example of a PPG Signal Sampled at a Data Rate of 10 Hz Using Five Pulses per Sample

COMMUNICATIONS INTERFACE

The ADPD188GG supports both an SPI and I²C serial interface, although only one can be used at any given time in the actual application. All internal registers are accessed through the selected communications interface.

I²C INTERFACE

The ADPD188GG I²C conforms to the *UM10204 I²C-Bus Specification and User Manual, Rev. 05—9 October 2012*, available from NXP Semiconductors. The device supports fast mode (400 kbps) data transfer. Register read and write operations are supported, as shown in Figure 20. The 7-bit I²C slave address for the device is 0x64. If the I²C interface is being used, the \overline{CS} pin must be pulled high to disable the SPI port.

Single-word and multiword read operations are supported. For a single register read, the host sends a no acknowledge (NACK) after the second data byte is read and a new register address is needed for each access.

For multiword operations, each pair of data bytes is followed by an acknowledge (ACK) from the host until the last byte of the last word is read. The host indicates the last read word by sending a no acknowledge. When reading from the FIFO (Register 0x60), the data is automatically advanced to the next word in the FIFO, and the space is freed. When reading from other registers, the register address is automatically advanced to the next register, allowing the user to read without readdressing each register, thereby reducing the amount of overhead required to read multiple registers. This auto-increment does not apply to the register that precedes the FIFO, Register 0x5F, or the last data register, Register 0x7E.

All register writes are single-word only and require 16 bits (one word) of data.

The software reset (Register 0x0F, Bit 0) returns an acknowledge. The device then returns to standby mode with all registers in the default state.

Table 13. Definitions of I²C Terminology

Term	Description
SCL	Serial clock.
SDA	Serial address and data.
Master	The device that initiates a transfer, generates clock signals, and terminates a transfer.
Slave	The device addressed by a master. The ADPD188GG operates as a slave device.
Start (S)	A high to low transition on the SDA line while SCL is high; all transactions begin with a start condition.
Start (Sr)	Repeated start condition.
Stop (P)	A low to high transition on the SDA line while SCL is high. A stop condition terminates all transactions.
ACK	During the acknowledge (ACK) or no acknowledge (NACK) clock pulse, the SDA line is pulled low, and it remains low.
NACK	During the ACK or NACK clock pulse, the SDA line remains high.
Slave Address	After a start (S), a 7-bit slave address is sent, which is followed by a data direction bit (read or write).
Read (R)	A 1 indicates a request for data.
Write (W)	A 0 indicates a transmission.

I²C WRITE

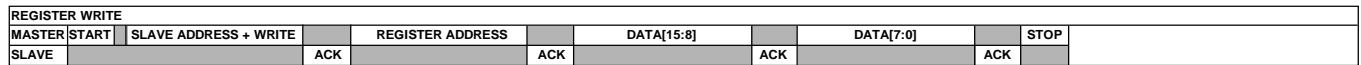

I²C SINGLE-WORD READ MODE

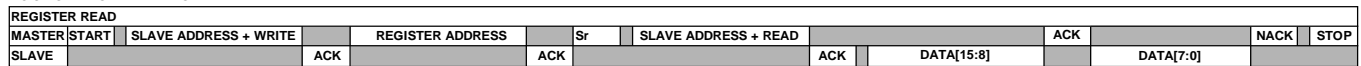

I²C MULTIWORD READ MODE

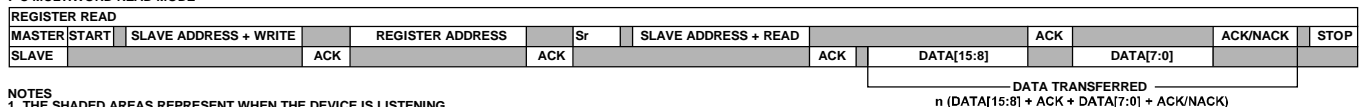

NOTES
1. THE SHADED AREAS REPRESENT WHEN THE DEVICE IS LISTENING.

Figure 20. I²C Write and Read Operations

1611-0/0

SPI PORT

The SPI port uses a 4-wire interface, consisting of the \overline{CS} , MOSI, MISO, and SCLK signals, and it is always a slave port. The \overline{CS} signal goes low at the beginning of a transaction and high at the end of a transaction. The SCLK signal latches MOSI on a low to high transition. The MISO data is shifted out of the device on the falling edge of SCLK and must be clocked into a receiving device, such as a microcontroller, on the SCLK rising edge. The MOSI signal carries the serial input data, and the MISO signal carries the serial output data. The MISO signal remains three-state until a read operation is requested, which allows other SPI-compatible peripherals to share the same MISO line. All SPI transactions have the same basic format shown in Table 14. A timing diagram is shown in Figure 3. Write all data MSB first.

Table 14. Generic Control Word Sequence

Byte 0	Byte 1	Byte 2	Subsequent Bytes
Address[6:0], W/R	Data[15:8]	Data[7:0]	Data[15:8], Data[7:0]

The first byte written in a SPI transaction is a 7-bit address, which is the location of the address being accessed, followed by the W/R bit. This bit determines whether the communication is a write (Logic Level 1) or a read (Logic Level 0). This format is shown in Table 15.

Table 15. SPI Address and Write/R Byte Format

Bit 0	Bit 1	Bit 2	Bit 3	Bit 4	Bit 5	Bit 6	Bit 7
A6	A5	A4	A3	A2	A1	A0	W/R

Data on the MOSI pin is captured on the rising edge of the clock, and data is propagated on the MISO pin on the falling edge of the clock. The maximum read and write speed for the SPI slave port is 10 MHz.

A sample timing diagram for a multiple word SPI write operation to a register is shown in Figure 21. A sample timing diagram of a single-word SPI read operation is shown in Figure 22. The MISO pin transitions from being three-state to being driven following the reception of a valid \overline{R} bit. In this example, Byte 0 contains the address and the W/R bit, and subsequent bytes carry the data. A sample timing diagram of a multiple word SPI read operation is shown in Figure 23. In Figure 21 to Figure 23, rising edges on SCLK are indicated with an arrow, signifying that the data lines are sampled on the rising edge.

When performing multiple word reads or writes, the data address is automatically incremented to the next consecutive address for subsequent transactions except for Address 0x5F, Address 0x60 (FIFO), and Address 0x7F.

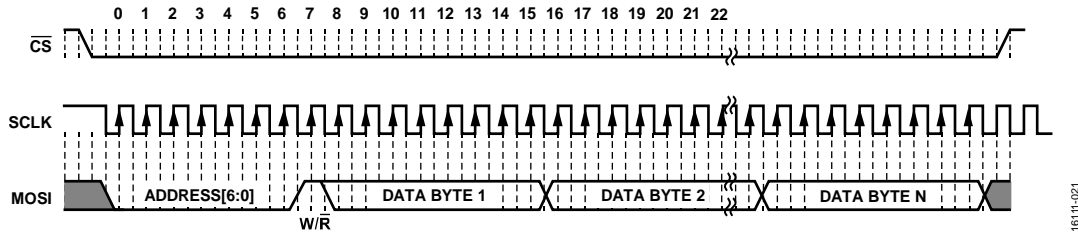

Figure 21. SPI Slave Write Clocking (Burst Write Mode, N Bytes)

16111-021

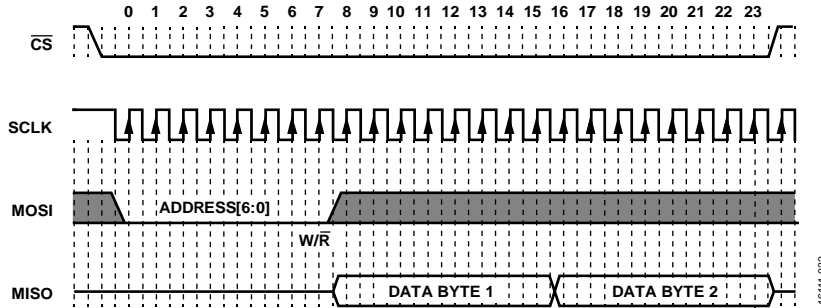

Figure 22. SPI Slave Read Clocking (Single-Word Mode, Two Bytes)

16111-022

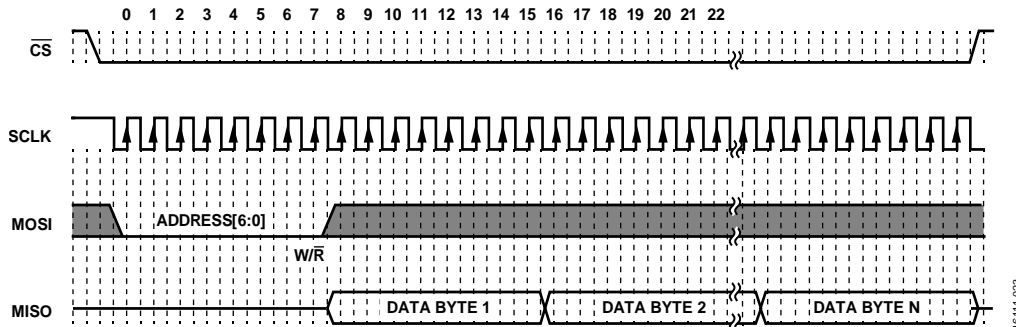

Figure 23. SPI Slave Read Clocking (Burst Read Mode, N Bytes)

16111-023

APPLICATIONS INFORMATION

TYPICAL CONNECTION DIAGRAM

Figure 24 shows the recommended connection diagram for the ADPD188GG using the SPI communications port. Figure 25 shows a circuit using the I²C port. The desired communications port, together with the GPIO0 and GPIO1 lines, connects to a system microprocessor or sensor hub. When using the SPI port, the I²C interface must be disabled by connecting the SDA and SCL pins high to 1.8 V. When using the I²C interface, the SPI is disabled by connecting CS to 1.8 V. Tie the unused inputs, SCLK and MOSI, to ground. The EXT_IN1 and EXT_IN 2 pins are current inputs and can be connected to external sensors. A voltage source can be connected to the EXT_IN1 and EXT_IN2 pins through a series resistance, effectively converting the voltage into a current (see the Using the EXT_IN 1 and EXT_IN 2 Inputs with a Voltage Source section).

Provide a regulated 1.8 V supply, tied to VDD1 and VDD2. The VLEDx level uses a standard regulator circuit according to the peak current requirements specified in Table 1 and calculated in the Calculating Current Consumption section. Place 0.1 μF ceramic decoupling capacitors as close as possible to VDD1 and VDD2; a 1.0 μF ceramic capacitor must be placed as close as possible to the VREF pin.

For best noise performance, connect AGND, DGND, and LGND together at a large conductive surface such as a ground plane, ground pour, or large ground trace.

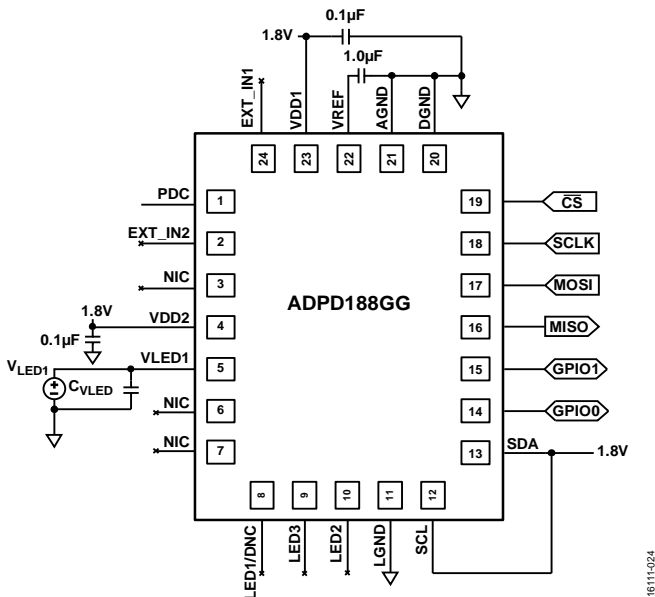

Figure 24. SPI Mode Connection Diagram

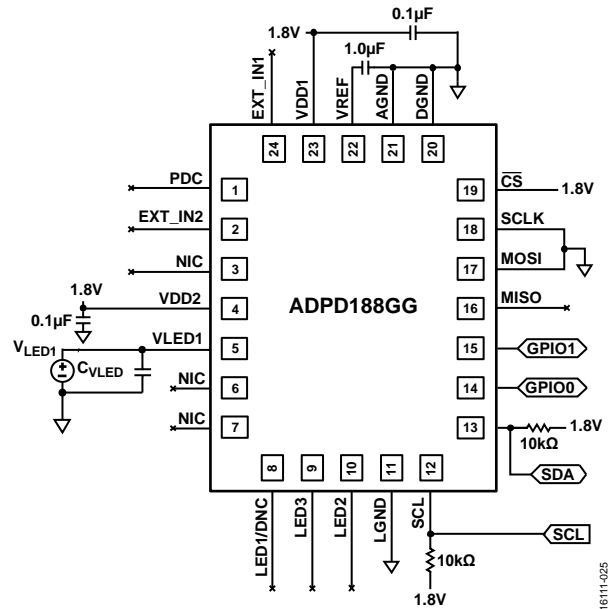

Figure 25. I²C Mode Connection Diagram

LAND PATTERN

Figure 26 shows the recommended PCB footprint (land pattern). Table 8 and Figure 4 provide the recommended soldering profile.

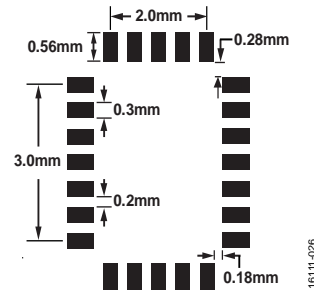

Figure 26. Land Pattern

RECOMMENDED START-UP SEQUENCE

At power-up, the device is in standby mode (Register 0x10 = 0x0), as shown in Figure 17. The ADPD188GG does not require a particular power-up sequence.

From standby mode, to begin measurement, initiate the ADPD188GG as follows:

1. Set the CLK32K_EN bit (Register 0x4B, Bit 7) to start the sample clock (32 kHz clock). This clock controls the state machine. If this clock is off, the state machine is not able to transition as defined by Register 0x10.
2. Write 0x1 to Register 0x10 to force the device into program mode. Step 1 and Step 2 can be swapped, but the actual state transition does not occur until both steps occur.
3. Write additional control registers in any order while the device is in program mode to configure the devices as required.
4. Write 0x2 to Register 0x10 to start normal sampling operation.

To terminate normal operation, follow this sequence to place the ADPD188GG in standby mode:

1. Write 0x1 to Register 0x10 to force the devices into program mode.
2. Write to the registers in any order while the devices are in program mode.
3. Write 0x00FF to Register 0x00 to clear all interrupts. If desired, clear the FIFO as well by writing 0x80FF to Register 0x00.
4. Write 0x0 to Register 0x10 to force the devices into standby mode.
5. Optionally, stop the 32 kHz clock by resetting the CLK32K_EN bit (Register 0x4B, Bit 7). Register 0x4B, Bit 7 = 0 is the only write that must be written when the device is in standby mode (Register 0x10 = 0x0). If 0 is written to this bit while in program mode or normal mode, the devices become unable to transition into any other mode, including standby mode, even if they are subsequently written to do so. As a result, the power consumption in what appears to be standby mode is greatly elevated. For this reason, and due to the very low current draw of the 32 kHz clock while in operation, it is recommended from an ease of use perspective to keep the 32 kHz clock running after it is turned on.

READING DATA

The ADPD188GG provides multiple methods for accessing the sample data. Each time slot can be independently configured to provide data access using the FIFO or the data registers. Interrupt signaling is also available to simplify timely data access. The FIFO is available to loosen the system timing requirements for data accesses.

Reading Data Using the FIFO

The ADPD188GG includes a 128-byte FIFO memory buffer that can be configured to store data from either or both time

slots. Register 0x11 selects the type of data from each time slot to be written to the FIFO. Note that both time slots can be enabled to use the FIFO, but only if their output data rate is the same.

$$\text{Output Data Rate} = f_{\text{SAMPLE}}/N_x$$

where:

f_{SAMPLE} is the sampling frequency.

N_x is the averaging factor for each time slot (N_A for Time Slot A and N_B for Time Slot B). In other words, $N_A = N_B$ must be true to store data from both time slots in the FIFO.

Data packets are written to the FIFO at the output data rate. A data packet for the FIFO consists of a complete sample for each enabled time slot. Data for each photodiode channel can be stored as either 16 or 32 bits. Each time slot can store 2, 4, 8, or 16 bytes of data per sample, depending on the mode and data format. To ensure that data packets are intact, new data is only written to the FIFO if there is sufficient space for a complete packet. Any new data that arrives when there is not enough space is lost. The FIFO continues to store data when sufficient space exists. Always read FIFO data in complete packets to ensure that data packets remain intact.

The number of bytes currently stored in the FIFO is available in Register 0x00, Bits[15:8]. A dedicated FIFO interrupt is also available and automatically generates when a specified amount of data is written to the FIFO.

Interrupt-Based Method

To read data from the FIFO using an interrupt-based method, use the following procedure:

1. In program mode, set the configuration of the time slots as desired for operation.
2. Write Register 0x11 with the desired data format for each time slot.
3. Set FIFO_THRESH in Register 0x06, Bits[13:8] to the interrupt threshold. A recommended value for this is the number of 16-bit words in a data packet, minus 1. This causes an interrupt to generate when there is at least one complete packet in the FIFO.
4. Enable the FIFO interrupt by writing a 0 to the FIFO_INT_MASK in Register 0x01, Bit 8. Also, configure the interrupt pin (GPIO0) by writing the appropriate value to the bits in Register 0x02.
5. Enter normal operation mode by setting Register 0x10 to 0x2.
6. When an interrupt occurs,
 - a. There is no requirement to read the FIFO_SAMPLES bits, because the interrupt is generated only if there is one or more full packets. Optionally, the interrupt routine can check for the presence of more than one available packet by reading these bits.
 - b. Read a complete packet using one or more multiword accesses using Register 0x60. Reading the FIFO automatically frees the space for new samples.

The FIFO interrupt automatically clears immediately upon reading any data from the FIFO and is set again only when the FIFO is written and the number of words is above the threshold.

Polling Method

To read data from the FIFO in a polling method, use the following procedure:

1. In program mode, set the configuration of the time slots as desired for operation.
2. Write Register 0x11 with the desired data format for each time slot.
3. Enter normal operation mode by setting Register 0x10 to 2.

Next, begin the polling operations.

1. Wait for the polling interval to expire.
2. Read the FIFO_SAMPLES bits (Register 0x00, Bits[15:8]).
3. If $\text{FIFO_SAMPLES} \geq$ the packet size, read a packet using the following steps:
 - a. Read a complete packet using one or more multiword accesses via Register 0x60. Reading the FIFO automatically frees the space for new samples.
 - b. Repeat Step 1.

When a mode change is required, or any other disruption to normal sampling is necessary, the FIFO must be cleared. Use the following procedure to clear the state and empty the FIFO:

1. Enter program mode by setting Register 0x10 to 0x1.
2. Write 1 to Register 0x00, Bit 15.

Reading Data from Registers Using Interrupts

The latest sample data is always available in the data registers and is updated simultaneously at the end of each time slot. The data value for each photodiode channel is available as a 16-bit value in Register 0x64 through Register 0x67 for Time Slot A, and Register 0x68 through Register 0x6B for Time Slot B. If allowed to reach their maximum value, Register 0x64 through Register 0x6B clip. If Register 0x64 through Register 0x6B saturate, the unsaturated (up to 27 bits) values for each channel are available in Register 0x70 through Register 0x77 for Time Slot A and Register 0x78 through Register 0x7F for Time Slot B. Sample interrupts are available to indicate when the registers are updated and can be read. To use the interrupt for a given time slot, use the following procedure:

1. Enable the sample interrupt by writing a 0 to the appropriate bit in Register 0x01. To enable the interrupt for Time Slot A, write 0 to Bit 5. To enable the interrupt for Time Slot B, write 0 to Bit 6. Either or both interrupts can be set.
2. Configure the interrupt pin (GPIOx) by writing the appropriate value to the bits in Register 0x02.
3. An interrupt generates when the data registers are updated.
4. The interrupt handler must perform the following:
 - a. Read Register 0x00 and observe Bit 5 or Bit 6 to confirm which interrupt has occurred. This step is not required if only one interrupt is in use.
 - b. Read the data registers before the next sample can be written. The system must have interrupt latency and

service time short enough to respond before the next data update, based on the output data rate.

- c. Write a 1 to Bit 5 or Bit 6 in Register 0x00 to clear the interrupt.

If both time slots are in use, it is possible to use only the Time Slot B interrupt to signal when all registers can be read. It is recommended to use the multiword read to transfer the data from the data registers.

Reading Data from Registers Without Interrupts

If the system interrupt response is not fast or predictable enough to use the interrupt method, or if the interrupt pin (GPIOx) is not used, it is possible to obtain reliable data access by using the data hold mechanism. To guarantee that the data read from the registers is from the same sample time, it is necessary to prevent the update of samples while reading the current values. The method for doing register reads without interrupt timing is as follows:

1. Write a 1 to SLOTA_DATA_HOLD or SLOTB_DATA_HOLD (Register 0x5F, Bit 1 and Bit 2, respectively) for the time slot requiring access (both time slots can be accessed). This setting prevents sample updates.
2. Read the registers as desired.
3. Write a 0 to the SLOTA_DATA_HOLD or SLOTB_DATA_HOLD bits (Register 0x5F, Bit 1 and Bit 2, respectively) previously set. Sample updates are allowed again.

Because a new sample may arrive while the reads are occurring, this method prevents the new sample from partially overwriting the data being read.

CLOCKS AND TIMING CALIBRATION

The ADPD188GG operates using two internal time bases. A 32 kHz clock sets the sample timing, and a 32 MHz clock controls the timing of internal functions such as LED pulsing and data capture. Both clocks are internally generated and exhibit device to device variation of approximately 10% (typical).

Heart rate monitoring (HRM) applications require an accurate time base to achieve an accurate count of beats per minute. The ADPD188GG provides a simple calibration procedure for both clocks.

Calibrating the 32 kHz Clock

This procedure calibrates items associated with the output data rate. Calibration of this clock is important for items where an accurate data rate is important, such as heart rate measurements.

To calibrate the 32 kHz clock,

1. Set the sampling frequency to the highest the system can handle, such as 2000 Hz. Because the 32 kHz clock controls sample timing, its frequency is readily accessible via the GPIO0 pin. Configure the interrupt by writing the appropriate value to Bits[2:0] in Register 0x02 and set the interrupt to occur at the sampling frequency by writing 0x0 to Register 0x01, Bit 5 or Bit 6. Monitor the GPIO0 pin. The interrupt frequency must match the set sample frequency.

- If the monitored interrupt frequency is less than the set sampling frequency, decrease the CLK32K_ADJUST bits (Register 0x4B, Bits[5:0]). If the monitored interrupt frequency is larger than the set sampling frequency, increase the CLK32K_ADJUST bits.
- Repeat Step 1 until the monitored interrupt signal frequency is close to the set sampling frequency.

Calibrating the 32 MHz Clock

This procedure calibrates items associated with the fine timing within a sample period, such as LED pulse width and spacing, and assumes that the 32 kHz clock is already calibrated.

To calibrate the 32 MHz clock,

- Write 0x1 to Register 0x5F, Bit 0.
- Enable the CLK_RATIO calculation by writing 0x1 to Register 0x50, Bit 5 (CLK32M_CAL_EN). This function counts the number of 32 MHz clock cycles in two cycles of the 32 kHz clock. With this function enabled, this value is stored in Register 0x0A, Bits[11:0] and nominally this ratio is 2000 (0x07D0).
- Calculate the 32 MHz clock error as follows:

$$\text{Clock Error} = 32 \text{ MHz} \times (1 - \text{CLK_RATIO}/2000)$$
- Adjust the frequency by setting Bits[7:0] in Register 0x4D per the following equation:

$$\text{CLK32M_ADJUST} = \text{Clock Error}/109 \text{ kHz}$$
- Write 0x0 to Register 0x50, Bit 5 to reset the CLK_RATIO function.
- Repeat Step 1 through Step 5 until the desired accuracy is achieved.
- Write 0x1 to Register 0x5F, Bit 0, and set the GPIO0 pin back to the mode desired for normal operation.

OPTIONAL TIMING SIGNALS AVAILABLE ON GPIO0 AND GPIO1

The ADPD188GG provides a number of different timing signals, available via the GPIO0 and GPIO1 pins, to enable ease of system synchronization and flexible triggering options. Each

GPIOx pin can be configured as an open-drain output if they are sharing the bus with other drivers, or they can be configured to always drive the bus. Both outputs also have polarity control in situations where a timing signal must be inverted from the default.

Table 16. GPIOx Control Settings

Pin Name	Register, Bits	Setting Description
GPIO0	0x02, Bit 0	0: polarity active high 1: polarity active low
	0x02, Bit 1	0: always drives the bus 1: drives the bus when asserted
	0x02, Bit 2	0: disables the GPIO0 pin drive 1: enables the GPIO0 pin drive
GPIO1	0x02, Bit 8	0: polarity active high 1: polarity active low
	0x02, Bit 9	0: always drives the bus 1: drives the bus when asserted
	0x4F, Bit 6	0: disables the GPIO1 pin drive 1: enables the GPIO1 pin drive

The various available timing signals are controlled by the settings in Register 0x0B, Bits[12:8] of this register control the timing signals available on GPIO1, and Bits[4:0] control the timing signals available on GPIO0. All of the timing signals described in this data sheet are available on either (or both) of the GPIO0 and GPIO1 pins. Timing diagrams are shown in Figure 27 and Figure 28. The time slot settings used to generate the timing diagrams are described in Table 17.

Table 17. ADPD188GG Settings Used for the Timing Diagrams Shown in Figure 27 and Figure 28

Register	Setting	Description
0x31	0x0118	Time Slot A: 1 LED pulse
0x36	0x0418	Time Slot B: 4 LED pulses
0x15	0x0120	Time Slot A decimation = 4, Time Slot B decimation = 2

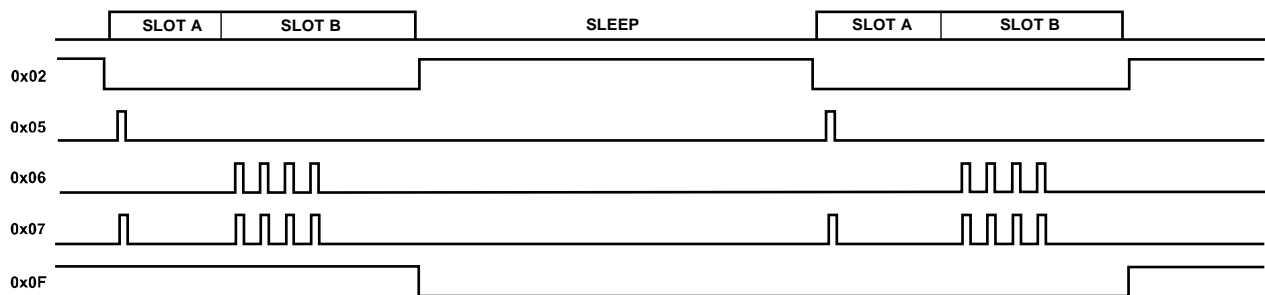

Figure 27. Optional Timing Signals Available on GPIOx—Register 0x0B, Bits[12:8] or Bits[4:0] = 0x02, 0x05, 0x06, 0x07, and 0x0F

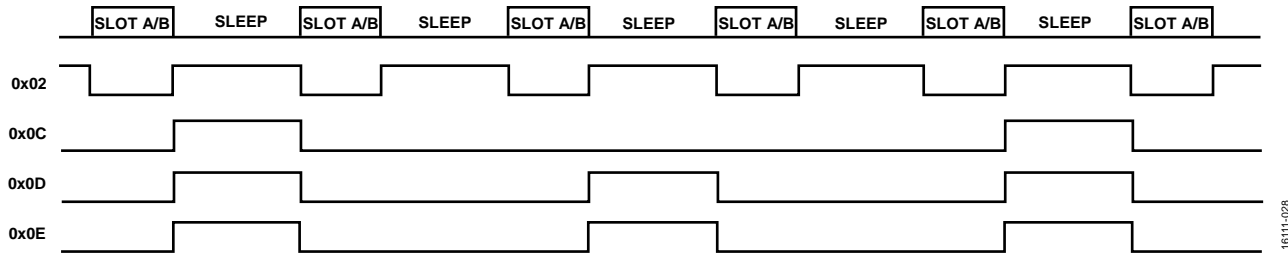

Figure 28. Optional Timing Signals Available on GPIOx—Register 0x0B, Bits[12:8] or Bits[4:0] = 0x02, 0x0C, 0x0D, and 0x0E

Interrupt Function

Setting Register 0x0B, Bits[12:8] or Bits[4:0] = 0x01 configures the respective pin to perform the interrupt function as defined by the settings in Register 0x01.

Sample Timing

Setting Register 0x0B, Bits[12:8] or Bits[4:0] = 0x02 configures the respective pin to provide a signal that asserts at the beginning of the first time slot of the current sample and deasserts at the end of the last time slot of the current sample. For example, if both time slots are enabled, this signal asserts at the beginning of Time Slot A and deasserts at the end of Time Slot B. If only a single time slot is enabled, the signal asserts at the beginning of the enabled time slot and deasserts at the end of this same time slot.

Pulse Outputs

Three options are available to provide a copy of the LED pulse outputs. Setting Register 0x0B, Bits[12:8] or Bits[4:0] = 0x05 provides a copy of the Time Slot A LED pulses on the respective pin. A setting of 0x06 provides the Time Slot B pulses, and a setting of 0x07 provides the pulse outputs of both time slots.

Output Data Cycle Signal

There are three options available to provide a signal that indicates when the output data is written to the output data registers or to the FIFO. Setting Register 0x0B, Bits[12:8] or Bits[4:0] = 0x0C provides a signal that indicates that a data value is written for Time Slot A. A setting of 0x0D provides a signal that indicates that a data value is written for Time Slot B, and 0x0E provides a signal to indicate that a value is written for either time slot. The signal asserts at the end of the time slot, when the output data is already written, and deasserts at the start of the subsequent sample. This timing signal is especially useful in situations where the FIFO is being used. For example, one of the GPIOx pins can be configured to provide an interrupt after the FIFO reaches the FIFO threshold set in Register 0x06, Bits[13:8], while the other GPIOx pin can be configured to provide the output data cycle signal. This signal can be used to trigger a peripheral device, such as an accelerometer, so that time aligned signals are provided to the processor.

$f_s/2$ Output

Setting Register 0x0B, Bits[12:8] or Bits[4:0] = 0x0F configures the respective pin to provide a signal that toggles at half the sampling rate. The $f_s/2$ timing signal always starts in an active low state when the device switches from standby mode to normal operating mode and transitions to a high state at the completion of the first sample.

Logic 0 Output

Setting Register 0x0B, Bits[12:8] or Bits[4:0] = 0x10 configures the respective pin to provide a Logic 0 output.

Logic 1 Output

Setting Register 0x0B, Bits[12:8] or Bits[4:0] = 0x11 configures the respective pin to provide a Logic 1 output.

32 kHz Oscillator Output

Setting Register 0x0B, Bits[12:8] or Bits[4:0] = 0x13 configures the respective pin to provide a copy of the on-board 32 kHz oscillator.

LED DRIVER PINS AND LED SUPPLY VOLTAGE

The LED driver pins (LED1/DNC, LED2, and LED3) have an absolute maximum voltage rating of 3.6 V. Any voltage exposure over this rating affects the reliability of the device operation and, in certain circumstances, causes the device to completely cease proper operation. The voltage of the LED driver pins must not be confused with the supply voltages for the LEDs themselves (V_{LED1} and V_{LED2}). These are the voltages applied to the anodes of the internal LEDs connected at VLED1.

LED DRIVER OPERATION

The LED drivers for the ADPD188GG are current sinks. Typical LED driver current vs. LED driver voltage is shown in Figure 9. Figure 24 shows the basic schematic of how the ADPD188GG connects to an LED through the LED driver. The Determining the Average Current section and the Determining CVLED section define the requirements for the bypass capacitor (C_{VLED}) and the supply voltages of the LEDs (V_{LED}).

DETERMINING THE AVERAGE CURRENT

When the ADPD188GG drives an LED, it drives the LED in a series of short pulses. Figure 29 shows the typical ADPD188GG configuration of a pulse burst sequence. In this sequence, the LED pulse width, t_{LED_PULSE} , is 3 μ s, and the LED pulse period, t_{LED_PERIOD} , is 19 μ s. The goal of C_{VLED} is to buffer the LED between individual pulses. In the worst case scenario, where the pulse train shown in Figure 29 is a continuous sequence of short pulses, the V_{LED} supply must supply the average current. Therefore, calculate $I_{LED_AVERAGE}$ as follows:

$$I_{LED_AVERAGE} = (t_{LED_PULSE}/t_{LED_PERIOD}) \times I_{LED_PEAK} \quad (1)$$

where:

$I_{LED_AVERAGE}$ is the average current needed from the V_{LED} supply. It is also the V_{LED} supply current rating.

I_{LED_PEAK} is the peak current setting of the LED.

For the numbers shown in Figure 29, $I_{LED_AVERAGE} = 3/19 \times I_{LED_PEAK}$. For typical LED timing, the average V_{LED} supply current is $3/19 \times 250 \text{ mA} = 39.4 \text{ mA}$, indicating that the V_{LED} supply must support a dc current of 40 mA.

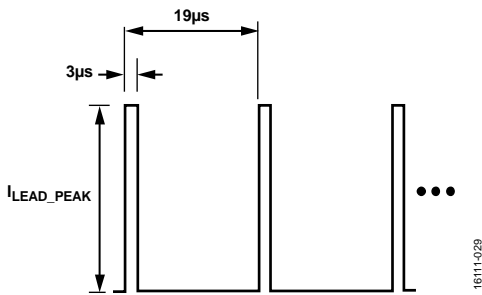

Figure 29. Typical LED Pulse Burst Sequence Configuration

DETERMINING C_{VLED}

To determine the C_{VLED} capacitor value, determine the maximum forward-bias voltage, $V_{FB_LED_MAX}$, of the LED in operation. From Figure 30, I_{LED_PEAK} converts to $V_{FB_LED_MAX}$. For example, with a 200 mA current, $V_{FB_LED_MAX}$ is 3.65 V. Any series resistance in the LED path must also be included in this voltage. When designing the LED path, keep in mind that small resistances can add up to large voltage drops when a 200 mA current is driven through the resistor. These resistances can be unnecessary constraints on the V_{LED} supply.

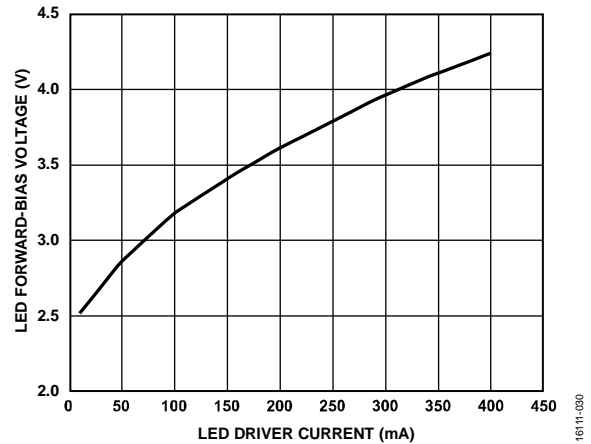

Figure 30. Typical LED Forward-Bias Voltage Drop as a Function of the LED Driver Current

For the C_{VLED} capacitor to be sized correctly, do not deplete it during the pulse of the LED to the point where the voltage on the capacitor is less than the forward-bias on the LED. To calculate the minimum value for the V_{LED} bypass capacitor, use the following equation:

$$C_{VLED} = \frac{t_{LED_PULSE} \times I_{LED_PEAK}}{V_{LED_MIN} - (V_{FB_LED_MAX} + 0.6)} \quad (2)$$

where:

t_{LED_PULSE} is the LED pulse width.

I_{LED_PEAK} is the maximum forward-bias current on the LED used in operating the device.

V_{LED_MIN} is the lowest voltage from the V_{LED} supply with no load.

$V_{FB_LED_MAX}$ is the maximum forward-bias voltage required on the LED to achieve I_{LED_PEAK} .

The numerator of the C_{VLED} equation sets up the total discharge amount in coulombs from the bypass capacitor to satisfy a single programmed LED pulse of the maximum current. The denominator represents the difference between the lowest voltage from the V_{LED} supply and the LED required voltage. The LED required voltage is the voltage of the anode of the LED such that the 0.6 V compliance of the LED driver at 200 mA and the forward-bias voltage of the LED operating at the maximum current is satisfied. For a typical ADPD188GG example, assume that the lowest value for the V_{LED} supply is 4.4 V, and that the peak current is 200 mA for two 525 nm LEDs in parallel. The minimum value for C_{VLED} is then equal to 4 μ F.

$$C_{VLED} = (3 \times 10^{-6} \times 0.20)/(4.4 - (3.65 + 0.6)) = 4.0 \mu\text{F} \quad (3)$$

As shown in Equation 3, the minimum supply voltage drops close to the maximum anode voltage, and the demands on C_{VLED} become more stringent, forcing the capacitor value higher. It is important to plug the correct values into these equations. For example, using an average value for V_{LED_MIN} instead of the worst-case value for V_{LED_MIN} can cause a problem; therefore, adding sufficient margin on C_{VLED} is strongly recommended.

USING EXTERNAL LEDES

The ADPD188GG LED driver is also connected to an external package pin so that the driver can drive external LEDs, if desired. Figure 31 shows a connection diagram that enables driving external LEDs.

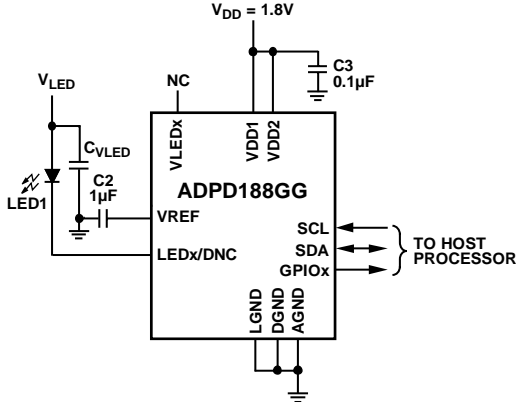

Figure 31. Using the ADPD188GG LED Drivers to Drive External LEDs

CALCULATING CURRENT CONSUMPTION

The current consumption of the ADPD188GG depends on the user selected operating configuration, as described in the following equations.

Total Power Consumption

To calculate the total power consumption, use Equation 4.

$$\text{Total Power} = I_{VDD_AVERAGE} \times V_{DD} + I_{LED_AVERAGE} \times V_{LED} \quad (4)$$

where:

$I_{VDD_AVERAGE}$ is the average V_{DD} supply current (supplied at VDD1 and VDD2).

V_{DD} is the voltage applied at the VDD1 and VDD2 pins.

$I_{LED_AVERAGE}$ is the average LED supply current.

V_{LED} is the voltage at the VLEDx pins, respectively.

Average V_{DD} Supply Current

To calculate the average V_{DD} supply current, use Equation 5.

$$I_{VDD_AVG} = DR \times ((I_{AFE_A} \times t_{SLOTA}) + (I_{AFE_B} \times t_{SLOTB}) + Q_{PROC_x}) + I_{VDD_STANDBY} \quad (5)$$

where:

DR is the data rate in Hz.

$I_{VDD_STANDBY} = 0.2 \mu\text{A}$.

Q_{PROC_x} is an average charge associated with a processing time, as follows:

When only Time Slot A is enabled,

$$Q_{PROC_A} (C) = 0.35 \times 10^{-6}$$

When only Time Slot B is enabled,

$$Q_{PROC_B} (C) = 0.24 \times 10^{-6}$$

When Time Slot A and Time Slot B are enabled,

$$Q_{PROC_AB} (C) = 0.40 \times 10^{-6}$$

$$I_{AFE_x} (A) = 3.0 \times 10^{-3} + (1.5 \times 10^{-3} \times \text{NUM_CHANNELS}) + (4.6 \times 10^{-3} \times I_{LEDX_PK} / \text{SCALE_X}) \quad (6)$$

$$t_{SLOTx} (\text{sec}) = \text{LEDx_OFFSET} + \text{LEDx_PERIOD} \times \text{PULSE_COUNT} \quad (7)$$

where:

NUM_CHANNELS is the number of active channels.

I_{LEDX_PK} is the peak LED current, expressed in amps, for the LED enabled in that particular time slot.

SCALE_X is the scale factor for the LED current drive determined by Bit 13 of the ILED_COARSE register.

LEDx_OFFSET is the pulse start time offset expressed in seconds.

LEDx_PERIOD is the pulse period expressed in seconds.

PULSE_COUNT is the number of pulses.

Note that if either Time Slot A or Time Slot B are disabled, $I_{AFE_x} = 0$ for that respective time slot.

Average V_{LEDA} Supply Current

To calculate the average V_{LEDA} supply current, use Equation 8.

$$I_{LED_AVG_A} = \text{SLOTA_LED_WIDTH} \times I_{LEDA_PK} \times DR \times \text{PULSE_COUNT} \quad (8)$$

where:

SLOTA_LED_WIDTH is the LED pulse width expressed in seconds.

I_{LEDA_PK} is the peak current, expressed in amps, for the Time Slot A LED.

Average V_{LEDB} Supply Current

To calculate the average V_{LEDB} supply current, use Equation 9.

$$I_{LED_AVG_B} = \text{SLOTB_LED_WIDTH} \times I_{LEDB_PK} \times DR \times \text{PULSE_COUNT} \quad (9)$$

where:

SLOTB_LED_WIDTH is the LED pulse width expressed in seconds.

I_{LEDB_PK} is the peak current, expressed in amps, for the Time Slot B LED.

Optimizing SNR per Watt in a Signal Limited System

In practice, optimizing for peak SNR is not always practical.

One scenario in which the PPG signal has a poor SNR is the signal limited regime. In this scenario, the LED current reaches an upper limit before the desired dc return level is achieved.

Tuning in this case starts where the peak SNR tuning stops. The starting point is nominally a 50k gain, as long as the lowest LED current setting of 12 mA does not saturate the photodiode and the 50k gain provides enough protection against intense background light. In these cases, use a 25k gain as the starting point.

The goal of the tuning process is to bring the dc return signal to a specific ADC range, such as 50% or 60%. The ADC range choice is a function of the margin of headroom needed to prevent saturation as the dc level fluctuates over time. The SNR of the PPG waveform is always some percentage of the dc level. If the target level cannot be achieved at the base gain, increase the gain and repeat the procedure. The tuning system may need to place an upper limit on the gain to prevent saturation from ambient signals.

Tuning the Pulse Count

After the LED peak current and TIA gain are optimized, increasing the number of pulses per sample increases the SNR by the square root of the number of pulses. There are two ways to increase the pulse count. The pulse count registers (Register 0x31, Bits[15:8], and Register 0x36, Bits[15:8]) change the number of pulses per internal sample. Register 0x15, Bits[6:4] and Bits[10:8], controls the number of internal samples that are averaged together before the data is sent to the output. Therefore, the number of pulses per sample is the pulse count register multiplied by the number of subsequent samples being averaged. In general, the internal sampling rate increases as the number of internal sample averages increase to maintain the desired output data rate. The SNR/watt is most optimal with pulse count values of 16 or less. Above pulse count values of 16, the square root relationship does not hold in the pulse count register. However, this relationship continues to hold when averaged between samples using Register 0x15.

Note that increasing LED peak current increases SNR almost directly proportional to LED power, whereas increasing the number of pulses by a factor of n results in only a nominal \sqrt{n} increase in SNR.

When using the sample sum/average function (Register 0x15), the output data rate decreases by the number of summed samples. To maintain a static output data rate, increase the sample frequency (Register 0x12) by the same factor as that selected in Register 0x15. For example, for a 100 Hz output data rate and a sample sum/average of four samples, set the sample frequency to 400 Hz.

Improving SNR Using Integrator Chopping

The last stage in the analog front end that is integrated into the ADPD188GG data path is a charge integrator. The integrator uses an on and off integration sequence, synchronized to the emitted light pulse, which acts as an additional high-pass filter to remove offsets, drifts, and low frequency noise from the previous stages. However, the integrating amplifier can itself introduce low frequency signal content at a low level. The ADPD188GG has an integrator chop mode that enables additional chopping in the digital domain to remove this signal. This chopping is achieved by using even numbers of pulses per sample and inverting the integration sequence for half of those sequences. In the calculation to combine the digitized result of each of the pulses of the sample, the sequences with an inverted integrator sequence are subtracted and the sequences with a

normal integrator sequence are added. An example diagram of the integrator chopping sequence is shown in Figure 32.

The result is that any low frequency signal contribution from the integrator is eliminated, leaving only the integrated signal, which results in higher SNR, especially at higher numbers of pulses and at lower TIA gains where the noise contribution of the integrator becomes more pronounced.

Digital chopping is enabled using the registers and bits detailed in Table 18. The bit fields define the chopping operation for the first four pulses. This 4-bit sequence is then repeated for all subsequent pulses. In Figure 32, a sequence is shown where the second and fourth pulses are inverted while the first and third pulses remain in the default polarity (noninverted). This configuration is achieved by setting Register 0x17, Bits[3:0] = 0xA and Register 0x1D, Bits[3:0] = 0xA for Time Slot A and Time Slot B, respectively. To complete the operation, the math must be adjusted using Register 0x58. In this example, set Register 0x58, Bits[9:8] and Register 0x58, Bits[11:10] to b01 to add the third pulse and subtract the fourth pulse for Time Slot A and Time Slot B, respectively. Set Register 0x58, Bits[2:1] and Register 0x58, Bits[6:5] to b01 to add the first pulse and subtract the second pulse for Time Slot A and Time Slot B, respectively. This sequence then repeats for every subsequent sequence of four pulses. An even number of pulses must be used with integrator chop mode.

When using integrator chop mode, the ADC offset registers (Register 0x18 through Register 0x1B for Time Slot A, and Register 0x1E through Register 0x21 for Time Slot B) must be set to 0. These settings are required because any digital offsets at the output of the ADC are automatically eliminated when the math is adjusted to subtract the inverted integration sequences while the default integration sequences are added. Integrator chop mode also eliminates the need to manually null the ADC offsets at startup in a typical application. Note that the elimination of the offset using chop mode may clip at least half of the noise signal when no input signal is present, which makes measuring the noise floor during characterization of the system difficult. For this reason, perform noise floor characterization of the system either with chop mode disabled or with chop mode enabled but with a minimal signal present at the input that increases the noise floor enough such that it is no longer clipped.

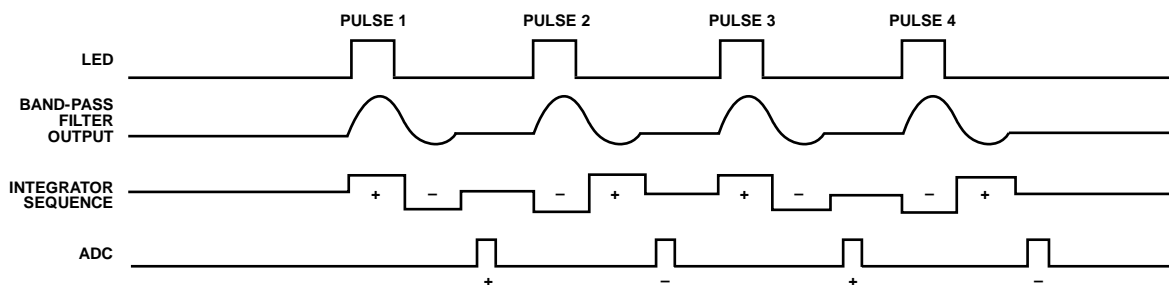

Figure 32. Diagram of Integrator Chopping Sequence

Table 18. Register Settings for Integrator Chop Mode

Hex Addr.	Data Bit(s)	Bit Name	Description
0x17	[3:0]	INTEG_ORDER_A	Integration sequence order for Time Slot A. Each bit corresponds to the polarity of the integration sequence of a single pulse in a four-pulse sequence. Bit 0 controls the integration sequence of Pulse 1, Bit 1 controls Pulse 2, Bit 2 controls Pulse 3, and Bit 3 controls Pulse 4. After four pulses, the sequence repeats. 0: normal integration sequence. 1: reversed integration sequence.
0x1D	[3:0]	INTEG_ORDER_B	Integration sequence order for Time Slot B. Each bit corresponds to the polarity of the integration sequence of a single pulse in a four-pulse sequence. Bit 0 controls the integration sequence of Pulse 1, Bit 1 controls Pulse 2, Bit 2 controls Pulse 3, and Bit 3 controls Pulse 4. After four pulses, the sequence repeats. 0: normal integration sequence. 1: reversed integration sequence
0x58	[11:10]	FLT_MATH34_B	Time Slot B control for adding and subtracting Sample 3 and Sample 4 in a four-pulse sequence (or any multiple of four pulses, for example, Sample 15 and Sample 16 in a 16-pulse sequence). 00: add third and fourth. 01: add third and subtract fourth. 10: subtract third and add fourth. 11: subtract third and fourth.
	[9:8]	FLT_MATH34_A	Time Slot A control for adding and subtracting Sample 3 and Sample 4 in a four-pulse sequence (or any multiple of four pulses, for example, Sample 15 and Sample 16 in a 16-pulse sequence). 00: add third and fourth. 01: add third and subtract fourth. 10: subtract third and add fourth. 11: subtract third and fourth.
	[6:5]	FLT_MATH12_B	Time Slot B control for adding and subtracting Sample 1 and Sample 2 in a four-pulse sequence (or any multiple of four pulses, for example, Sample 13 and Sample 14 in a 16-pulse sequence). 00: add first and second. 01: add first and subtract second. 10: subtract first and add second. 11: subtract first and second.
	[2:1]	FLT_MATH12_A	Time Slot A control for adding and subtracting Sample 1 and Sample 2 in a four-pulse sequence (or any multiple of four pulses, for example, Sample 13 and Sample 14 in a 16-pulse sequence). 00: add first and second. 01: add first and subtract second. 10: subtract first and add second. 11: subtract first and second.

MECHANICAL CONSIDERATIONS FOR COVERING THE ADPD188GG

In some applications, it may be necessary to cover the ADPD188GG to protect it from moisture. The ADPD188GG is designed with this requirement in mind. The unique cross section of the device, as shown in Figure 13, prevents light from going directly from the LED to the detector even with a reasonably thick window. It is recommended that the window thickness be <0.7 mm and the air gap between the module and the window be kept to <0.5 mm for optimal operation.

TIA ADC MODE

Figure 33 shows a way to put the ADPD188GG into a mode that effectively runs the TIA directly into the ADC without using the analog band-pass filter (BPF) and integrator. This mode is

referred to as TIA ADC mode. There are two basic applications of TIA ADC mode. In normal operation, all of the background light is blocked from the signal chain, and therefore, cannot be measured. TIA ADC mode can measure the amount of background and ambient light. This mode can also measure other dc input currents, such as leakage resistance.

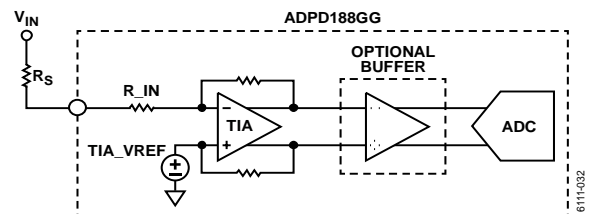

Figure 33. TIA ADC Mode Block Diagram

When the devices are in TIA ADC mode, the BPF and the integrator stage are bypassed. This bypass effectively wires the TIA directly into the ADC. At the set sampling frequency, the ADC samples Channel 1 through Channel 4 in sequential order, and each sample is taken at 1 μ s intervals.

There are two modes of operation in TIA ADC mode. One mode is an inverting configuration where TIA ADC mode directly drives the ADC. This mode is enabled by setting Register 0x43 (Time Slot A) and/or Register 0x45 (Time Slot B) to 0xB065, which bypasses the BPF and the integrator. With the ADC offset register(s) for the desired channel set to 0 and the TIA_VREF set to 1.265 V, the output of the ADC is at ~13,000 codes for a single pulse and a zero input current condition. As the input current from the photodiode increases, the ADC output decreases toward 0.

The recommended TIA ADC mode is one in which the BPF is bypassed and the integrator is configured as a buffer. This mode is enabled by writing 0xAE65 to Register 0x43 (Time Slot A) and/or Register 0x45 (Time Slot B) to bypass the BPF. Additionally, to configure the integrator as a buffer, set Bit 7 of Register 0x42 (Time Slot A) and/or Register 0x44 (Time Slot B) to 1, and set Bit 7 of Register 0x58 to 1. With the ADC offset register(s) for the desired channel set to 0 and TIA_VREF set to 1.265 V, the output of the ADC is at ~13,000 codes for a single pulse and a zero input current condition. As the input current from the photodiode increases, the ADC output decreases toward 0.

When configuring the integrator as a buffer, there is the option of either using a gain of 1 or a gain of 0.7. Using the gain of 0.7 increases the usable dynamic range at the input to the TIA. The buffer gain is set using Register 0x42, Bit 9 for Time Slot A and Register 0x44, Bit 9 for Time Slot B. Setting this bit to 0 (default) sets a gain of 1. Setting this bit to 1 configures the buffer with a gain of 0.7.

The ADC output (ADC_{OUT}) is calculated as follows:

$$ADC_{OUT} = 8192 \pm (((2 \times TIA_VREF - 2 \times i \times R_F - 1.8 \text{ V}) / 146 \mu\text{V/LSB}) \times SLOTx_BUF_GAIN) \quad (11)$$

where:

TIA_VREF is the bias voltage for the TIA (the default value is 1.265 V).

i is the input current to the TIA.

R_F is the TIA feedback resistor.

$SLOTx_BUF_GAIN$ is either 0.7 or 1, based on the setting of Register 0x42, Bit 9 and Register 0x44, Bit 9.

Equation 11 is an approximation and does not account for internal offsets and gain errors. The calculation also assumes that the ADC offset registers are set to 0.

One time slot can be used in TIA ADC mode at the same time the other time slot is being used in normal pulsed mode. This capability is useful for monitoring ambient and pulsed signals at the same time. The ambient signal is monitored during the time slot configured for TIA ADC mode, while the pulsed signal,

with the ambient signal rejected, is monitored in the time slot configured for normal mode.

Protecting Against TIA Saturation in Normal Operation

One of the reasons to monitor TIA ADC mode is to protect against environments that may cause saturation. One concern when operating in high light conditions, especially with larger photodiodes, is that the TIA stage may become saturated while the ADPD188GG continue to communicate data. The resulting saturation is not typical. The TIA, based on its settings, can only handle a certain level of photodiode current. Based on the way the ADPD188GG is configured, if there is a current level from the photodiode that is larger than the TIA can handle, the TIA output during the LED pulse effectively extends the current pulse, making it wider. The AFE timing is then violated because the positive portion of the band-pass filter output extends into the negative section of the integration window. Thus, the photosignal is subtracted from itself, causing the output signal to decrease when the effective light signal increases.

To measure the response from the TIA and verify that this stage is not saturating, place the device in TIA ADC mode and slightly modify the timing. Specifically, sweep $SLOTx_AFE_OFFSET$ until two or three of the four channels reach a minimum value (note that TIA is in an inverting configuration). All four channels do not reach this minimum value because, typically, 3 μ s LED pulse widths are used and the ADC samples the four channels sequentially at 1 μ s intervals. This procedure aligns the ADC sampling time with the LED pulse to measure the total amount of light falling on the photodetector (for example, background light + LED pulse).

To ensure that the TIA does not saturate, a safe operating region is typically at $\frac{3}{4}$ full scale and lower. Use Table 19 to determine how the output codes map to ADC levels on a per channel per pulse basis. These codes are not the same as in normal mode because the band-pass filter and integrator are not unity-gain elements.

Measuring PCB Parasitic Input Resistance

During the process of mounting the ADPD188GG, undesired resistance can develop on the inputs through assembly errors or debris on the PCB. These resistances can form between the anode and cathode, or between the anode and some other supply or ground. In normal operation, the ambient rejection feature of the ADPD188GG masks the primary effects of these resistances, making it very difficult to detect them. However, even at 1 M Ω to 10 M Ω , such resistance can impact performance significantly through added noise or decreased dynamic range. TIA ADC mode can be used to screen for these assembly issues.

Measuring Shunt Resistance on the Photodiode

A shunt resistor across the photodiode/EXT_INx does not generally affect the output level of the device in operation because the effective impedance of the TIA is very low, especially if the photodiode is held to 0 V in operation. However, such resistance can add noise to the system, degrading performance. The best

way to detect photodiode leakage, also called photodiode shunt resistance, is to place the device in TIA ADC mode in the dark and vary the operation mode cathode voltage. Setting the cathode to 1.3 V places 0 V across the photodiode because the anode is always at 1.3 V while in operation. Setting the cathode to 1.8 V places 0.5 V across the photodiode. Using the register settings in Table 1 to control the cathode voltage, measure the TIA ADC value at both voltages. Next, divide the voltage difference of 0.5 V by the difference of the ADC result after converting it to a current. This result is the approximate shunt resistance. Values greater than 10 M Ω may be difficult to measure, but this method is useful in identifying gross failures.

Measuring TIA Input Shunt Resistance

A resistance to develop between the TIA input and another supply or ground on the PCB is an example of another problem that can occur. These resistances can force the TIA into saturation prematurely. This premature saturation, in turn, takes away dynamic range from the device in operation and adds a Johnson noise component to the input. To measure these resistances, place the device in TIA ADC mode in the dark and start by measuring the TIA ADC offset level with the photodiode inputs disconnected (Register 0x14, Bits[11:8] = 0 or Register 0x14, Bits[7:4] = 0). From this, subtract the value of TIA ADC mode with the darkened photodiode connected and convert the difference into a current. If the value is positive, and the ADC signal decreased, the resistance is to a voltage higher than 1.3 V, such as V_{DD} . Current entering the TIA causes the output to drop. If the output difference is negative due to an increase of codes at the ADC, current is being pulled out of the TIA and there is a shunt resistance to a lower potential than 1.3 V, such as ground.

Using the EXT_IN 1 and EXT_IN 2 Inputs with a Voltage Source

The ADPD188GG can be used for voltage inputs. Voltage inputs can be measured in normal mode or in TIA ADC mode. If these inputs are not a result of stimulation from the LED driver, TIA ADC mode is preferred. To understand the conversion gain from a voltage through a series resistor, R_s , the current can be determined by following the schematic in Figure 34.

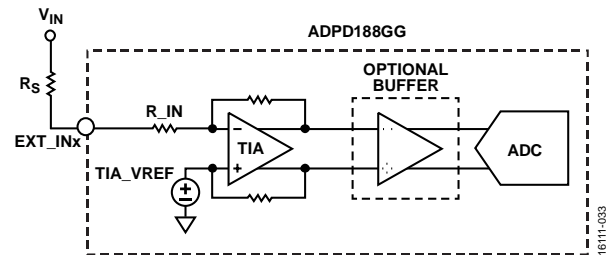

Figure 34. ADPD188GG Used for Voltage Inputs

$$\text{Input Current} = (V_{IN} - \text{TIA_VREF}) / (R_s + R_{IN})$$

Values for R_{IN} are listed in Table 2. R_{IN} is not needed for photodiode or other current inputs because the current of these inputs are not a function of the input resistance. Conversion from input current in amps to ADC codes (LSBs) follows Table 19 in TIA ADC mode. Current conversion in normal mode is listed in Table 2. The offset level shown in Table 19 represents the expected code value with zero current input. The conversion gain in nA/LSB can be added onto this for nonzero input currents.

Table 19. Analog Specifications for TIA ADC Mode and Digital Integrate Mode

Parameter	Test Conditions/Comments	Typ	Unit
TIA ADC Offset Level	Floating input (Input current = 0A); Register 0x43 and Register 0x45 = 0xAE65; Register 0x42 and Register 0x44, Bit 7 = 1, Register 0x58, Bit 7 = 1 TIA_VREF = Register 0x42 and Register 0x44, Bits[5:4] = 0 (1.14 V) TIA_VREF = Register 0x42 and Register 0x44, Bits[5:4] = 1 (1.01 V) TIA_VREF = Register 0x42 and Register 0x44, Bits[5:4] = 2 (0.89 V) TIA_VREF = Register 0x42 and Register 0x44, Bits[5:4] = 3 (1.27 V); recommended for PD inputs	11400 9700 8100 13200	LSB LSB LSB LSB
TIA ADC Saturation Levels ¹	Values expressed per channel, per sample; buffer gain = 1 25 k Ω 50 k Ω 100 k Ω 200 k Ω	38.32 19.16 9.58 4.79	μ A μ A μ A μ A
TIA ADC Resolution	Values expressed per channel, per sample; buffer gain = 1 25 k Ω 50 k Ω 100 k Ω 200 k Ω	2.92 1.5 0.73 0.37	nA/LSB nA/LSB nA/LSB nA/LSB

¹ TIA linear dynamic range is 85% of listed saturation levels

Table 20. Configuration Registers to Switch Between Normal Sample Mode and TIA ADC Mode

Address	Data Bits	Bit Name	Normal Mode Value	TIA ADC Mode Value	Description
0x42	[15:10]	SLOTA_AFE_MODE	0x07	Not applicable	In normal mode, this setting configures the integrator block for optimal operation. This setting is not important for TIA ADC mode.
	[9]	SLOTA_BUF_GAIN	0x0	0x0	0: buffer gain = 1.0. 1: buffer gain = 0.7.
	[7]	SLOTA_INT_AS_BUF	0x0	0x1	0: normal integrator configuration. 1: convert integrator to buffer amplifier in TIA ADC mode (required for 0x43 = 0xAE65).
0x43	[15:0]	SLOTA_AFE_CFG	0xADA5	0xAE65	Time Slot A AFE connection. 0xAE65: bypasses the band-pass filter. 0xB065: can also be used in TIA ADC mode. This setting bypasses the BPF and the integrator.
0x44	[15:10]	SLOTB_AFE_MODE	0x07	Not applicable	In normal mode, this setting configures the integrator block for optimal operation. This setting is not important for TIA ADC mode.
	[9]	SLOTB_BUF_GAIN	0x0	0x0	0: buffer gain = 1.0. 1: buffer gain = 0.7.
	[7]	SLOTB_INT_AS_BUF	0x0	0x1	0: normal integrator configuration. 1: convert integrator to buffer amplifier (required for 0x45 = 0xAE65).
0x45	[15:0]	SLOTB_AFE_CFG	0xADA5	0xAE65	Time Slot B AFE connection. 0xAE65: bypasses the band-pass filter. 0xB065: can also be used in TIA ADC mode. This setting bypasses the band-pass filter (BPF) and the integrator.
0x58	[7]	ENA_INT_AS_BUF	0x0	0x1	Enables the ability to configure the integrator as a buffer in TIA ADC mode

PULSE CONNECT MODE

In pulse connect mode, the photodiode input connections are pulsed according to the timing set up in the LED pulse timing registers. In this mode, if the LED pulse timing is set up to provide a 2 μ s LED pulse, the device pulses the connection to the photodiode input for 2 μ s instead of providing a 2 μ s LED pulse. This mode is an alternate to TIA ADC mode, allowing the entire

signal path, including the band-pass filter and integrator, to be used to measure ambient light as well as other types of measurements with different types of sensors (for example, ECG).

To enable pulse connect mode, the device is configured identically to normal mode, except that Register 0x14, Bits[3:2] = 0 for Time Slot B, and Register 0x14, Bits[1:0] = 0 for Time Slot A.

SYNCHRONOUS ECG AND PPG MEASUREMENT USING TIA ADC MODE

In wearable devices developed for monitoring the health care of patients, it is often necessary to have synchronized measurements of biomedical signals. For example, a synchronous measurement of patient ECG and PPG can be used to determine the pulse wave transit time (PWTT), which can then be used to estimate blood pressure.

The circuit shown in Figure 36 shows a synchronous ECG and PPG measurement using the AD8233 and the ADPD188GG. The AD8233 implements a two-pole, high-pass filter with a cutoff frequency at 0.3 Hz, and a two-pole, low-pass filter with a cutoff frequency of 37 Hz. The output of the AD8233 is fed to the EXT_IN1 current input of the ADPD188GG through a 200 kΩ resistor to convert the voltage output of the AD8233 into a current.

The ADPD188GG is configured to alternately measure the photodiode signal and the ECG signal from the AD8233 on consecutive time slots to provide fully synchronized PPG and ECG measurements. Data can be read out of the on-chip FIFO or straight from data registers. The ADPD188GG channel used to process the ECG signal is set up in TIA ADC mode and the

input bias voltage must be set to the 0.90 V setting using Bits[5:4] of Register 0x42 if the ECG signal is on Time Slot A, or Register 0x44 on Time Slot B. The TIA gain setting can be set to optimize the dynamic range of the signal path. The channel used to process the PPG signal is configured in its normal operating mode. Figure 35 shows a plot of a synchronized ECG and PPG measurement using the AD8233 with the ADPD188GG.

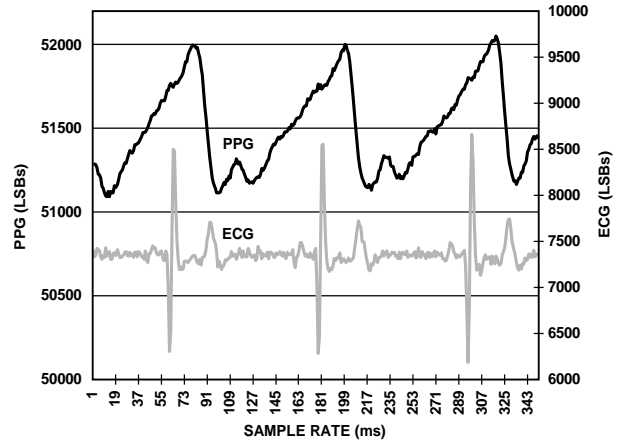

Figure 35. Plot of Synchronized ECG and PPG Waveforms

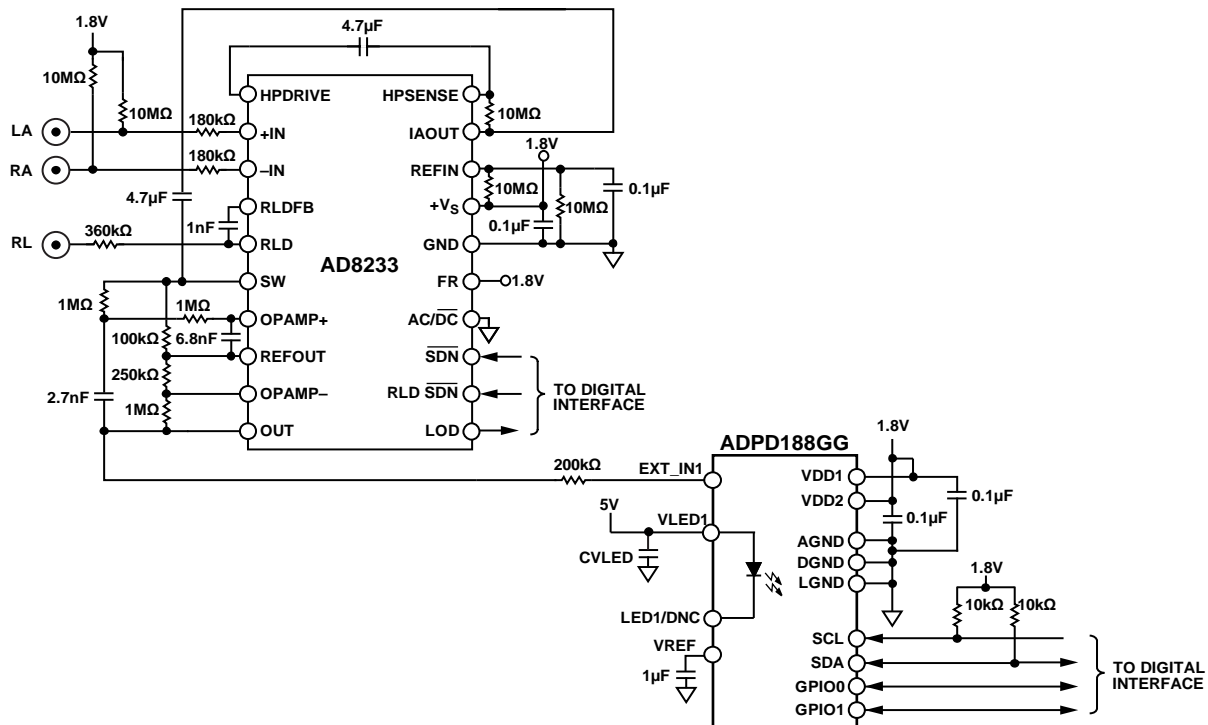

Figure 36. Synchronized PPG and ECG Measurement Using the ADPD188GG with the AD8233

FLOAT MODE

The ADPD188GG has a unique operating mode, float mode, that allows excellent SNR at low power in low light situations. In float mode, the photodiode is first preconditioned to a known state and then the photodiode anode is disconnected from the receive path of the ADPD188GG for a preset amount of float time. During the float time, light falls on the photodiode, either from ambient light, pulsed LED light, or a combination of the two depending on the operating mode. Charge from the sensor is stored directly on the capacitance of the sensor. At the end of the float time, the photodiode switches back into the receive path of the ADPD188GG and an inrush of the accumulated charge occurs, which is subsequently integrated by the integrator of the ADPD188GG, allowing the maximum amount of charge to be processed per pulse with the minimum amount of noise added by the signal path. The charge is integrated externally on the capacitance of the photodiode for as long as it takes to acquire maximum charge, independent of the amplifiers of the signal path, which adds noise to the signal.

Amplifier and ADC noise values are constant for a given measurement. For optimal SNR, it is desirable to have a greater amount of signal (charge) per measurement. In normal mode, because the pulse time is fixed, the charge per measurement can be increased only by increasing the LED drive current. For high light conditions, this is sufficient. In low light conditions, however, there is a limit to the available current. In addition, high current pulses can cause ground noise in some systems. Green LEDs have lower efficiency at high currents, and many battery designs do not deliver high current pulses as efficiently. Float mode allows the user the flexibility to increase the amount of charge per measurement by either increasing the LED drive current or by increasing the float time. This flexibility is especially useful in low current transfer ratio (CTR) conditions, for example, 10 nA/mA, where normal mode requires multiple pulses to achieve an acceptable level of SNR.

In float mode, the signal path bypasses the BPF and uses only the TIA and integrator. In normal mode, the shape of the pulse is known (typically either 2 μ s or 3 μ s) and is consistent across devices and conditions. The shape of the signal coming through the BPF is also predictable, which allows a user to align the integrator timing with the zero crossing of the filtered signal. In float mode, the shape of the signal produced by the charge dump can differ across devices and conditions. A filtered signal cannot be reliably aligned; therefore, the BPF cannot be used. In float mode, the entire charge dump is integrated in the negative cycle of the integrator and the positive cycle cancels any offsets.

Float Mode Measurement Cycle

Figure 37 shows the float mode measurement cycle timing diagram, and the following details the points shown:

- The precondition period is shown prior to Point A. The photodiode is connected to the TIA, and the photocurrent flows into the TIA. The photodiode anode is held at 0.9 V (Register 0x42 and Register 0x44, Bits[5:4] = 0x2 sets TIA_VREF = 0.9 V). The photodiode is reverse biased to a maximum reverse bias of ~250 mV by setting Register 0x54, Bit 7 = 1 and Register 0x54, Bits[9:8] = 0x2 (for Time Slot A). At this point, the output of the TIA (TIA_OUT) = TIA_VREF - (I_{PD} × R_F), where I_{PD} is the current flowing from the PD into the ADPD1080/ADPD1081 input, and the integrator is off.
- At Point A, the photodiode is disconnected from the receive path. Light continues to fall on the photodiode producing a charge that accumulates directly on the photodiode capacitance. As the charge accumulates, the voltage at the floating photo-diode anode rises. The TIA is disconnected from the input to the ADPD188GG so that no current flows through the TIA, and the TIA output is at TIA_VREF. Just prior to Point B, the integrator resets to 0. In the Float Mode for Synchronous LED Measurements section, the LED pulses during the time period between Point A and Point D. Float times of <4 μ s are not allowed.
- At Point B, the integrator begins its positive integration phase. Small dc offsets between the TIA output and the integrator reference causes the integrator output to ramp up for positive offsets or ramp down for negative offsets. The photodiode continues to accumulate charge during this period.
- At Point C, the integrator begins its negative integration phase. This reversal in polarity begins to cancel any signal caused by offsets. This offset cancellation continues through Point E, where all offsets are cancelled completely.
- At Point D, the photodiode switches into the receive path where all the charge that has accumulated on the photodiode capacitance during the float time is dumped into the TIA. The typical charge dump time is less than 2 μ s. As the current flows through the TIA, the output of the TIA responds with a large negative signal. Because the integrator is in the negative integration phase at this point, the output of the integrator rises as the input current to the device integrates back to total charge. Between Point D and Point E, any light incident on the photodiode produces additional photocurrent, which is immediately integrated by the integrator as charge.
- At Point E, the TIA disconnects from the receive path and the TIA output returns to TIA_VREF. Between Point E and Point F, the integrator completes the negative integration phase and cancellation of the offsets.
- At Point F, the integrator output is held until sampled by the ADC.

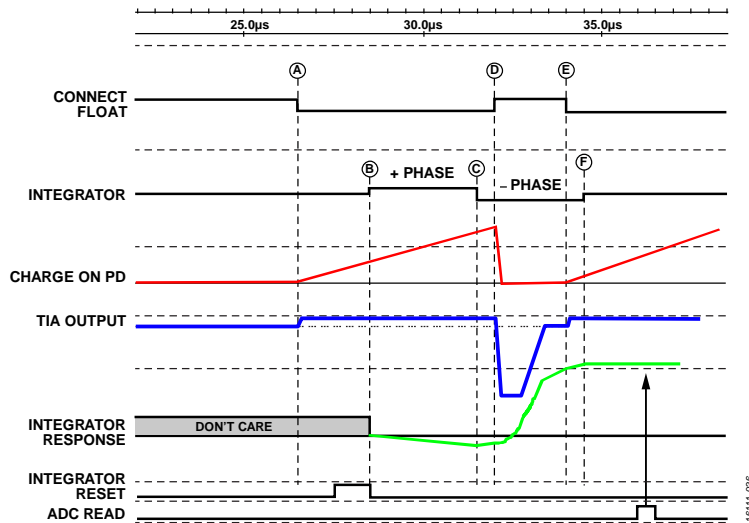

Figure 37. Float Mode Measurement Cycle Timing Diagram

Float Mode Limitations

When using float mode, the limitations of the mode must be well understood. For example, there is a finite amount of charge that can accumulate on the capacitance of the photodiode, and there is also a maximum amount of charge that can be integrated by the integrator. Based on an initial reverse bias of 250 mV on the photodiode and assuming that the photodiode begins to become nonlinear at ~200 mV of forward bias, there is ~450 mV of headroom for the anode voltage to increase from its starting point at the beginning of the float time before the charge ceases to accumulate in a linear fashion. It is desirable to operate only in the linear region of the photodiode (see Figure 38). To verify that float mode is operating in the linear region of the diode, the user can perform a simple check. Record data at a desired float time, and then record data at half the float time. It is recommended that the ratio of the two received signals be 2:1. If this ratio does not hold true, the diode is likely beginning to forward bias at the longer float time and becomes nonlinear.

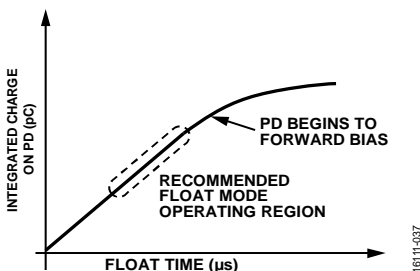

Figure 38. Transfer Function of Integrated Charge on the Photodiode vs. Float Time

The maximum amount of charge that can be stored on the photodiode capacitance and remain in the linear operating region of the sensor can be estimated by

$$Q = CV$$

where:

Q is the integrated charge.

C is the capacitance of the photodiode.

V is the amount of voltage change across the photodiode before the photodiode becomes nonlinear.

For a typical discrete optical design using a 7 mm² photodiode with 70 pF capacitance and 450 mV of headroom, the maximum amount of charge that can be stored on the photodiode capacitance is 31.5 pC.

In addition, consider the maximum amount of charge the integrator of the ADPD188GG can integrate. The integrator can integrate up to 7.6 pC. When this charge is referred back to the input, consider the TIA gain. When the TIA gain is at 200 kΩ, the input referred charge is at a 1:1 ratio to the integrated charge on the integrator. For 100 kΩ gain, it is 2:1; for 50 kΩ gain, it is 4:1; and for 25 kΩ gain, it is 8:1. For the previous example using a photodiode with 70 pF capacitance, use 50 kΩ TIA gain and set the float timing such that, for a single pulse, the output of the ADC is at 70% of full scale, which is a typical operating condition. Under these operating conditions, 5.3 pC integrates per pulse by the integrator for 21.2 pC of charge accumulated on the photodiode capacitance. For small CTR, however, it can take a long time to accumulate 21.2 pC of charge on the photodiode capacitance, in which case, use higher TIA gains according to how much charge can be accumulated in a given amount of time. Ultimately, float times are determined by the type of measurement being made (ambient or pulsed LED), the photodiode capacitance, and the CTR of the system.

Float Mode for Ambient Light Measurements

Float mode is used for ambient light measurements where the background light is sufficiently small. Use TIA ADC mode for ambient light measurements of higher intensities. Small amounts of light can be measured with adequate float times, allowing the incoming charge to accumulate to levels large enough to be measured above the noise floor of the system. The source of this light can be any combination of synchronous light (for example, from a pulsed LED) and asynchronous light (that is, background). If there is no system generated light source, the measurement is simply a measure of the background light.

Use a two pulse differential measurement technique to cancel out electrical drifts and offsets. Take two measurements, each of a different float time. The first float time is considerably shorter than the second pulse. After the two measurements are taken, Measurement 1 is subtracted from Measurement 2, which effectively cancels out any offset and drift common to both measurements. What is left is an ambient light measurement based on an amount of charge that is integrated over a time that is the difference of the first and second float times. For example, if Float Time 1 is 6 μ s and Float Time 2 is 26 μ s, the ambient

light measurement is based on 20 μ s of charge integrated on the photodiode capacitance with any offset and drift removed. In float mode for ambient light, the number of pulses must be set to two to cancel drifts and offsets because only the first pulse can be short. More than two pulses can be used; however, pulses two through n are always the same length. If drift cancellation is not required, any number of pulses can be used and added together. Figure 39 shows an example of float ambient mode timing, and Table 21 details the relevant registers that must be configured.

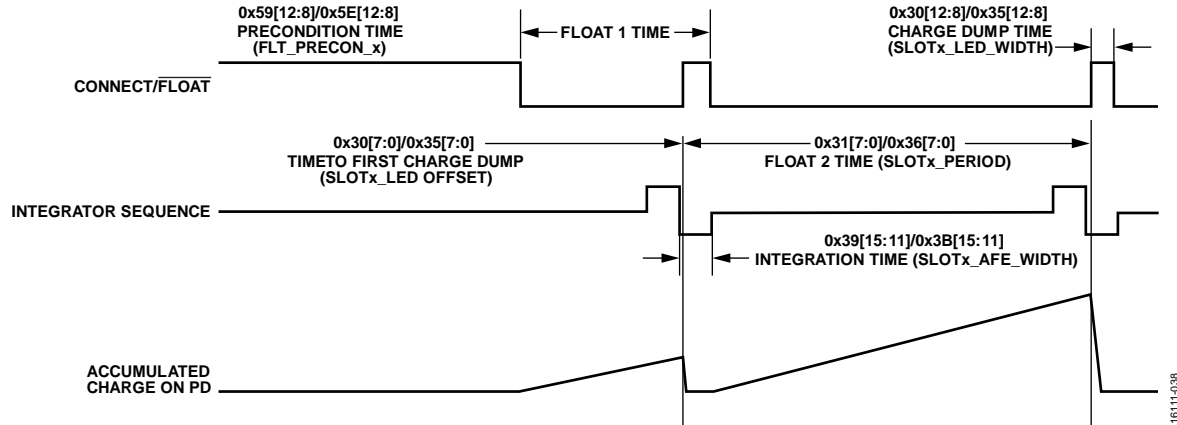

Figure 39. Example of Float Ambient Mode Timing

Table 21. Float Ambient Mode Registers

Group	Register Name	Register		Float Mode Description
		Time Slot A	Time Slot B	
Float Mode Operation	SLOTx_LED_SEL	0x14, Bits[1:0]	0x14, Bits[3:2]	Set to 0 to enable float mode.
	FLT_EN_x	0x5E, Bits[14:13]	0x59, Bits[14:13]	Set to 3 to enable float between connect pulses.
	FLT_MATH12_x	0x58, Bits[2:1]	0x58, Bits[6:5]	Set to 2 to subtract first pulse and add second pulse.
	SLOTx_AFE_CFG	0x43, Bits[15:0]	0x45, Bits[15:0]	Set to 0xAE65 for TIA and integrator, bypass BPF.
	SLOTx_TIA_VREF	0x42, Bits[5:4]	0x44, Bits[5:4]	Set to 2 for TIA_VREF = 0.9 V.
	SLOTx_V_CATHODE	0x54, Bits[9:8]	0x54, Bits[11:10]	Set to 2 for 250 mV reverse bias on the photodiode at the precondition.
	REG54_VCAT_ENABLE	0x54, Bit 7	0x54, Bit 7	Set to 1 to override Register 0x3C cathode voltage settings.
Float Mode Timing	FLT_PRECON_x	0x5E, Bits[12:8]	0x59, Bits[12:8]	Precondition time (to start of Float 1 time).
	SLOTx_PERIOD	0x31, Bits[7:0]	0x36, Bits[7:0]	8 LSBs of float period in μ s; Float 2 time = SLOTx_PERIOD 2 MSBs of float period.
	SLOTx_LED_WIDTH	0x30, Bits[12:8]	0x35, Bits[12:8]	Connect time in μ s; this is the amount of time given to dump the accumulated charge from the photodiode capacitance; typically, this is set to 2 μ s.
	SLOTx_LED_OFFSET	0x30, Bits[7:0]	0x35, Bits[7:0]	Time to first charge dump; Float 1 time = (SLOTx_LED_OFFSET + SLOTx_LED_WIDTH) – FLT_PRECONx.
	SLOTx_AFE_WIDTH	0x39, Bits[15:11]	0x3B, Bits[15:11]	Integration time in μ s; set to FLT_CONNx + 1.
	SLOTx_AFE_OFFSET	0x39, Bits[10:0]	0x3B, Bits[10:0]	Integrator start time in 31.25 ns increments; set to (SLOTx_LED_OFFSETx – SLOTx_AFE_WIDTH – 9.25) μ s.
	SLOTx_PULSES	0x31, Bits[15:8]	0x36, Bits[15:8]	Number of pulses; set to 2 for float ambient mode.

Float Mode for Synchronous LED Measurements

In float LED mode, photocurrent is generated from ambient light and pulsed LED light during the float time. Float LED mode is desirable in low signal conditions where the CTR is <10 nA/mA. In addition, float mode is a good option in situations where the user wants to limit the LED drive current of the green LEDs in a heart rate measurement to keep the forward voltage drop of the green LED to a level that allows the elimination of a boost converter for the LED supply. For example, the LED current can be limited to 10 mA to ensure that the LED voltage drop is ~3 V so that it can operate directly from the battery without the need of a boost converter. Float mode accumulates the received charge during longer LED pulses without adding noise from the signal path, effectively yielding the highest SNR and/or photon attainable.

As with float ambient mode, multiple pulses cancel electrical offsets and drifts; however, in float LED mode, the ambient light must also be cancelled because only the reflected return from the LED pulses is desired. To achieve this, use an even number of equal length pulses. For every pair of pulses, the LED flashes in one of the pulses and does not flash in the other. The return

from the LED + ambient + offset is present in one of the pulses. In the other, only the ambient light and offset is present. A subtraction of the two pulses is made that eliminates ambient light as well as any offset and drift. It is recommended to use groups of four pulses for measurement where the LED is flashed on Pulse 2 and Pulse 3. The accumulator adds Pulse 2 and Pulse 3 and then subtract Pulse 1 and Pulse 4. To gain additional SNR, use multiple groups of four pulses.

The settings of FLT_LED_FIRE_x, Register 0x5A, Bits[15:8] determine if the LED fires in which pulse position. Which pulse positions are added or subtracted is configured in the FLT_MATH12x and FLT_MATH34x bits of Register 0x58. These sequences are repeated in groups of four pulses. The value written to the FIFO or data registers is dependent on the total number of pulses per sample period. For example, if the device is setup for 32 pulses, the 4 pulse sequence, as defined in FLT_LED_FIRE_x and FLT_MATHxxx, repeats eight times and a single register or FIFO write of the final value based on 32 pulses executes. Table 22 details the relevant registers for float LED mode.

Table 22. Float LED Mode Registers

Group	Register Name	Register Address		Float Mode Description
		Time Slot A	Time Slot B	
Float Mode Operation	SLOTx_LED_SEL	0x14, Bits[1:0]	0x14, Bits[3:2]	Set to 0 to enable float mode.
	FLT_EN_x	0x5E, Bits[14:13]	0x59, Bits[14:13]	Set to 3 to enable float between connect pulses.
	FLT_MATH12_x	0x58, Bits[2:1]	0x58, Bits[6:5]	Set to 2 to subtract first pulse and add second pulse.
	FLT_MATH34_x	0x58, Bits[9:8]	0x58, Bits[11:10]	Set to 1 to add third pulse and subtract fourth pulse.
	SLOTx_AFE_CFG	0x43, Bits[15:0]	0x45, Bits[15:0]	Set to 0xAE65 for TIA + integrator, bypass BPF.
	SLOTx_TIA_VREF	0x42, Bits[5:4]	0x44, Bits[5:4]	Set to 2 for TIA_VREF = 0.9 V.
	SLOTx_V_CATHODE	0x54, Bits[9:8]	0x54, Bits[11:10]	Set to 2 for 250 mV reverse bias on the photodiode at the precondition.
REG54_VCAT_ENABLE	0x54, Bit 7	0x54, Bit 7	Set to 1 to override Register 0x3C cathode voltage settings.	
FLT_LED_SELECT_x	0x3E, Bits[15:14]	0x3F[15:14]	LED selection for float LED mode. 00 = no LED. 01 = LED1. 10 = LED2. 11 = LED3.	
Float Mode Timing	FLT_PRECON_x	0x5E, Bits[12:8]	0x59, Bits[12:8]	Precondition time (to start of float 1 time).
	SLOTx_PERIOD	0x31, Bits[7:0]	0x36, Bits[7:0]	8 LSBs of float period in μ s. Float 2 time = SLOTx_PERIOD. Float 2 time is valid for every pulse subsequent to the first pulse. Float 1 time must be set equal to Float 2 time in float LED mode.
	SLOTx_PERIOD	0x37, Bits[1:0]	0x37, Bits[9:8]	2 MSBs of float period.
	SLOTx_LED_WIDTH	0x30, Bits[12:8]	0x35, Bits[12:8]	Connect time in μ s, which is the amount of time given to dump the accumulated charge from the photodiode capacitance. Typically, it is set to 2 μ s.
SLOTx_LED_OFFSET	0x30, Bits[7:0]	0x35, Bits[7:0]	Time to first charge dump. Float 1 time = (SLOTx_LED_OFFSET + SLOTx_LED_WIDTH) – FLT_PRECONx. Float 1 time must be equal to Float 2 time for float LED mode.	

Group	Register Name	Register Address		Float Mode Description
		Time Slot A	Time Slot B	
	SLOTx_AFE_WIDTH	0x39, Bits[15:11]	0x3B, Bits[15:11]	Integration time in μ s. set to FLT_CONN + 1.
	SLOTx_AFE_OFFSET	0x39, Bits[10:0]	0x3B, Bits[10:0]	Integrator start time in 31.25 ns increments. Set to (SLOTx_LED_OFFSET – SLOTx_AFE_WIDTH – 9.25) μ s.
	SLOTx_PULSES	0x31, Bits[15:8]	0x36, Bits[15:8]	Number of pulses; must be set in multiples of 2, minimum 2.
	FLT_LED_WIDTH_x	0x3E, Bits[12:8]	0x3F, Bits[12:8]	LED pulse width for float LED mode in μ s.
	FLT_LED_OFFSET_x	0x3E, Bits[7:0]	0x3F, Bits[7:0]	Time of first LED pulse in float LED mode.
	FLT_LED_FIRE_x	0x5A, Bits[11:8]	0x5A, Bits[15:12]	In any given sequence of four pulses, fire the LED in the selected position. Selections are active low (that is, fire LED if 0). For example, in a sequence of four pulses on Time Slot B, Register 0x5A, Bit 12 is the first pulse, and Register 0x5A, Bit 15 is the fourth pulse. For a sequence of four pulses, fire the LED in the second and third pulses by writing 0x9 to Register 0x5A, Bits[15:12].

A timing diagram for a four pulse float LED sequence for Time Slot B is shown in Figure 40. In this example, the device is set up for LED pulses of 12 μ s that fall within a float period of 16 μ s, 2 μ s of which are used for dumping of the accumulated charge on the photodiode. The integration time is set to 3 μ s, which is 1 μ s more than the charge dump time to allow for timing margin when integrating the incoming charge. Note, there is a 9 μ s offset built into the integration start time. Take this offset into account when setting the SLOTx_AFE_OFFSET value. As shown in Figure 40, the time of the first charge dump is set to 30 μ s. SLOTx_AFE_OFFSET is set to 0x238 (17.75 μ s), taking into account the 3 μ s integration time, the 9 μ s offset, and an additional 250 ns for edge placement margin.

To calculate SLOTx_AFE_OFFSET, use the following equation:

$$SLOTx_AFE_OFFSET = SLOTx_LED_OFFSET - \\ SLOTx_AFE_WIDTH - 9.25 \mu s$$

Placement of the integration period is such that the negative phase of the integration is centered on the charge dump phase. The TIA is an inverting stage, therefore, placing the negative phase of the integration during the dumping of the charge from the photodiode causes the integrator to increase with the negative going output signal from the TIA.

The LED flashes in the second and third pulses of the four pulse sequence. Setting Register 0x58, Bits[6:5] = 2 and Register 0x58, Bits[11:10] = 1 forces the device to add the second and third pulses while subtracting the first and fourth pulses, effectively cancelling out the ambient light and electrical offsets and drift.

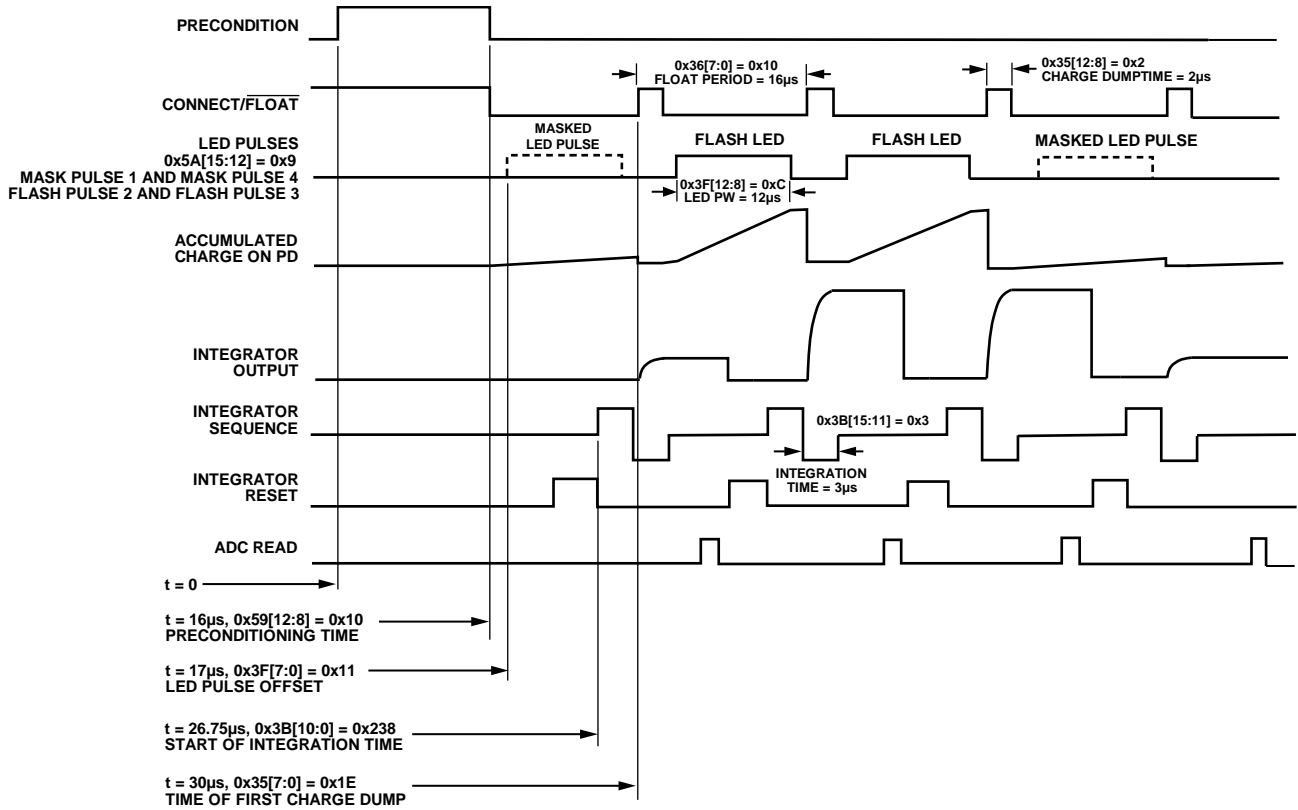

Figure 40. Example Timing Diagram of Four Pulse Float LED Mode Sequence

A comparison of float ambient mode vs. float LED mode is shown in Table 23 and Table 24.

Table 23. Float Ambient Mode—Measure Ambient Light Level

Pulse	Float Time	Integrated Charge	Calculation	Result
1	Shorter	Offset, Ambient 1 (shorter time)	Subtract	Ambient Measurement = Ambient 2 – Ambient 1 (offset cancels)
2	Longer	Offset, Ambient 1 (shorter time)	Add	
3	Not applicable	Not applicable	Not applicable	
4	Not applicable	Not applicable	Not applicable	

Table 24. Float LED Mode—Measurement Synchronous Reflected Light from LED

Pulse	Float Time	Integrated Charge	Calculation	Result
1	Equal	Offset + Ambient	Subtract	Sync LED response = reflected LED return (offset and ambient cancel)
2	Equal	Offset + Ambient + LED	Add	
3	Equal	Offset + Ambient + LED	Add	
4	Equal	Offset + Ambient	Subtract	

Monitoring Ambient Light Levels in Float LED Mode

In real-world applications, it is common for the ambient light levels to change constantly. When using float LED mode, increasing amounts of ambient light can approach levels where it uses an unacceptable amount of the dynamic range of the charge that can be stored on the photodiode capacitance. For this reason, it is required that the ambient light level is monitored so that configuration changes can be made when necessary, for example, float time, TIA gain, and operating mode. There are two ways to monitor ambient light levels. One way is to use TIA ADC mode in the alternate time slot and continuously monitor the ambient light level. The other way is to use a feature of the ADPD188GG where the ambient light level is automatically monitored in the background during float mode operation and is compared against a user-defined threshold. If the ambient light level exceeds this threshold by some user-defined number of times, a flag is set by the device that can be read by the user or can be output to a GPIO. Table 25 lists all the registers used to monitor the ambient light level while in float LED mode.

The user sets an ambient level threshold in the BG_THRESH register, which is the threshold by which the ADC result of the subtract cycles in float LED mode are compared against. The subtract cycles in float LED mode are the positions in the pulse sequence in which the LED pulse is masked; therefore, it is the background level measurement. The ADC result is equal to the raw ADC output minus the contents of the ADC offset register (Register 0x18 to Register 0x1B and Register 0x1E to Register 0x21). In the BG_COUNT register, the user sets a limit on the number of cycles that BG_THRESH is exceeded by the ADC result before the BG_STATUS bit is set for any particular channel. Every time the BG_THRESH value is exceeded by the ADC result during a subtract cycle, an internal counter increments. Each channel has its own counter. When this count exceeds the limit set in the BG_COUNT register, the BG_STATUS bit is set for the channel. The user can periodically monitor the BG_STATUS register to check for asserted bits. Alternatively, a GPIOx pin can be asserted if a BG_STATUS flag is set. See Table 25 for the various logical combinations of BG_STATUS flags and interrupts that can be brought out on a GPIOx.

Table 25. Registers for Monitoring the Ambient Light Level in Float LED Mode

Float Mode Register Name	Register		Description
	Time Slot A	Time Slot B	
BG_STATUS_x	0x04, Bits[3:0]	0x04, Bits[7:4]	Status of comparison between background light level and background threshold value (BG_THRESH). A 1 in any bit location means the threshold has been crossed BG_COUNT number of times. This register is cleared once it is read. Bit 0: Time Slot A, Channel 1 exceeded threshold count. Bit 1: Time Slot A, Channel 2 exceeded threshold count. Bit 2: Time Slot A, Channel 3 exceeded threshold count. Bit 3: Time Slot A, Channel 4 exceeded threshold count. Bit 4: Time Slot B, Channel 1 exceeded threshold count. Bit 5: Time Slot B, Channel 2 exceeded threshold count. Bit 6: Time Slot B, Channel 3 exceeded threshold count. Bit 7: Time Slot B, Channel 4 exceeded threshold count.
BG_THRESH_x	0x16, Bits[13:0]	0x1C[13:0]	The background threshold that is compared against the ADC result during the subtract cycles during float mode. If the ADC result exceeds the value in this register, BG_COUNT is incremented.
BG_COUNT_x	0x16, Bits[15:14]	0x1C[15:14]	This is the number of times the ADC value exceeds the BG_THRESH_x value during the float mode subtract cycles before the BG_STATUS bit is set. 0x0: never set BG_STATUS. 0x1: set when BG_THRESH_x is exceeded 1 time. 0x02: set when BG_THRESH_x is exceeded 4 times. 0x03: set when BG_THRESH_x is exceeded 16 times.
GPIO0_ALT_CFG	0x0B[4:0]	0x0B[4:0]	GPIO0 asserts for the following conditions: 0x10: logical OR of BG_STATUS_x, Bits[3:0]. 0x1A: logical OR of BG_STATUS_x, Bits[7:4]. 0x1B: logical OR of BG_STATUS_x, Bits[7:0]. 0x1C: logical OR of BG_STATUS_x, Bits[7:0] and INT.
GPIO1_ALT_CFG	0x0B[12:8]	0x0B[12:8]	GPIO1 asserts for the following conditions: 0x10: logical OR of BG_STATUS_x, Bits[3:0]. 0x1A: logical OR of BG_STATUS_x, Bits[7:4]. 0x1B: logical OR of BG_STATUS_x, Bits[7:0]. 0x1C: logical OR of BG_STATUS_x, Bits[7:0] and INT.

REGISTER LISTING

The recommended values are not shown. Only power-on reset values are shown in Table 26. The recommended values are largely dependent on use case.

Table 26. Numeric Register Listing

Hex. Addr.	Name	Bits	Bit 15	Bit 14	Bit 13	Bit 12	Bit 11	Bit 10	Bit 9	Bit 8	Reset	R/W		
			Bit 7	Bit 6	Bit 5	Bit 4	Bit 3	Bit 2	Bit 1	Bit 0				
0x00	Status	[15:8]	FIFO_SAMPLES[7:0]									0x0000	R/W	
		[7:0]	Reserved	SLOTB_INT	SLOTA_INT	Reserved								
0x01	INT_MASK	[15:8]	Reserved								FIFO_INT_MASK	0x00FF	R/W	
		[7:0]	Reserved	SLOTB_INT_MASK	SLOTA_INT_MASK	Reserved								
0x02	GPIO_DRV	[15:8]	Reserved						GPIO1_DRV	GPIO1_POL	0x0000	R/W		
		[7:0]	Reserved				GPIO0_ENA	GPIO0_DRV	GPIO0_POL					
0x04	BG_STATUS	[15:8]	Reserved									0x0000	R/W	
		[7:0]	BG_STATUS_B[3:0]				BG_STATUS_A[3:0]							
0x06	FIFO_THRESH	[15:8]	Reserved			FIFO_THRESH[5:0]						0x0000	R/W	
		[7:0]	Reserved											
0x08	DEVID	[15:8]	REV_NUM[7:0]									0x0916	R	
		[7:0]	DEV_ID[7:0]											
0x09	I2CS_ID	[15:8]	ADDRESS_WRITE_KEY[7:0]									0x00C8	R/W	
		[7:0]	SLAVE_ADDRESS[6:0]							Reserved				
0x0A	CLK_RATIO	[15:8]	Reserved				CLK_RATIO[11:8]						0x0000	R
		[7:0]	CLK_RATIO[7:0]											
0x0B	GPIO_CTRL	[15:8]	Reserved			GPIO1_ALT_CFG[4:0]						0x0000	R/W	
		[7:0]	Reserved			GPIO0_ALT_CFG[4:0]								
0x0D	SLAVE_ADDRESS_KEY	[15:8]	SLAVE_ADDRESS_KEY[15:8]									0x0000	R/W	
		[7:0]	SLAVE_ADDRESS_KEY[7:0]											
0x0F	SW_RESET	[15:8]	Reserved									0x0000	R/W	
		[7:0]	Reserved								SW_RESET			
0x10	Mode	[15:8]	Reserved									0x0000	R/W	
		[7:0]	Reserved						Mode[1:0]					
0x11	SLOT_EN	[15:8]	Reserved		RDOUT_MODE	FIFO_OVRN_PREVENT	Reserved			SLOTB_FIFO_MODE[2]	0x1000	R/W		
		[7:0]	SLOTB_FIFO_MODE[1:0]		SLOTB_EN	SLOTA_FIFO_MODE[2:0]			Reserved	SLOTA_EN				
0x12	FSAMPLE	[15:8]	FSAMPLE[15:8]									0x0028	R/W	
		[7:0]	FSAMPLE[7:0]											
0x14	PD_LED_SELECT	[15:8]	Reserved				SLOTB_PD_SEL[3:0]					0x0541	R/W	
		[7:0]	SLOTA_PD_SEL[3:0]			SLOTB_LED_SEL[1:0]		SLOTA_LED_SEL[1:0]						
0x15	NUM_AVG	[15:8]	Reserved						SLOTB_NUM_AVG[2:0]			0x0600	R/W	
		[7:0]	Reserved	SLOTA_NUM_AVG[2:0]			Reserved							
0x16	BG_MEAS_A	[15:8]	BG_COUNT_A[1:0]		BG_THRESH_A[13:8]							0x0000	R/W	
		[7:0]	BG_THRESH_A[7:0]											
0x17	INT_SEQ_A	[15:8]	Reserved									0x0000	R/W	
		[7:0]	Reserved				INTEG_ORDER_A[3:0]							
0x18	SLOTA_CH1_OFFSET	[15:8]	SLOTA_CH1_OFFSET[15:8]									0x2000	R/W	
		[7:0]	SLOTA_CH1_OFFSET[7:0]											
0x19	SLOTA_CH2_OFFSET	[15:8]	SLOTA_CH2_OFFSET[15:8]									0x2000	R/W	
		[7:0]	SLOTA_CH2_OFFSET[7:0]											
0x1A	SLOTA_CH3_OFFSET	[15:8]	SLOTA_CH3_OFFSET[15:8]									0x2000	R/W	
		[7:0]	SLOTA_CH3_OFFSET[7:0]											
0x1B	SLOTA_CH4_OFFSET	[15:8]	SLOTA_CH4_OFFSET[15:8]									0x2000	R/W	
		[7:0]	SLOTA_CH4_OFFSET[7:0]											
0x1C	BG_MEAS_B	[15:8]	BG_COUNT_B[1:0]		BG_THRESH_B[13:8]							0x0000	R/W	
		[7:0]	BG_THRESH_B[7:0]											

Hex. Addr.	Name	Bits	Bit 15	Bit 14	Bit 13	Bit 12	Bit 11	Bit 10	Bit 9	Bit 8	Reset	R/W	
			Bit 7	Bit 6	Bit 5	Bit 4	Bit 3	Bit 2	Bit 1	Bit 0			
0x1D	INT_SEQ_B	[15:8]	Reserved									0x0000	R/W
		[7:0]	Reserved				INTEG_ORDER_B[3:0]						
0x1E	SLOTB_CH1_OFFSET	[15:8]	SLOTB_CH1_OFFSET[15:8]									0x2000	R/W
		[7:0]	SLOTB_CH1_OFFSET[7:0]										
0x1F	SLOTB_CH2_OFFSET	[15:8]	SLOTB_CH2_OFFSET[15:8]									0x2000	R/W
		[7:0]	SLOTB_CH2_OFFSET[7:0]										
0x20	SLOTB_CH3_OFFSET	[15:8]	SLOTB_CH3_OFFSET[15:8]									0x2000	R/W
		[7:0]	SLOTB_CH3_OFFSET[7:0]										
0x21	SLOTB_CH4_OFFSET	[15:8]	SLOTB_CH4_OFFSET[15:8]									0x2000	R/W
		[7:0]	SLOTB_CH4_OFFSET[7:0]										
0x22	ILED3_COARSE	[15:8]	Reserved		ILED3_SCALE		Reserved				0x3000	R/W	
		[7:0]	Reserved	ILED3_SLEW[2:0]			ILED3_COARSE[3:0]						
0x23	ILED1_COARSE	[15:8]	Reserved		ILED1_SCALE		Reserved				0x3000	R/W	
		[7:0]	Reserved	ILED1_SLEW[2:0]			ILED1_COARSE[3:0]						
0x24	ILED2_COARSE	[15:8]	Reserved		ILED2_SCALE		Reserved				0x3000	R/W	
		[7:0]	Reserved	ILED2_SLEW[2:0]			ILED2_COARSE[3:0]						
0x25	ILED_FINE	[15:8]	ILED3_FINE[4:0]				ILED2_FINE[4:2]				0x630C	R/W	
		[7:0]	ILED2_FINE[1:0]		Reserved		ILED1_FINE[4:0]						
0x30	SLOTA_LED_PULSE	[15:8]	Reserved			SLOTA_LED_WIDTH[4:0]						0x0320	R/W
		[7:0]	SLOTA_LED_OFFSET[7:0]										
0x31	SLOTA_NUMPULSES	[15:8]	SLOTA_PULSES[7:0]									0x0818	R/W
		[7:0]	SLOTA_PERIOD[7:0]										
0x34	LED_DISABLE	[15:8]	Reserved						SLOTB_LED_DIS	SLOTA_LED_DIS	0x0000	R/W	
		[7:0]	Reserved										
0x35	SLOTB_LED_PULSE	[15:8]	Reserved			SLOTB_LED_WIDTH[4:0]						0x0320	R/W
		[7:0]	SLOTB_LED_OFFSET[7:0]										
0x36	SLOTB_NUMPULSES	[15:8]	SLOTB_PULSES[7:0]									0x0818	R/W
		[7:0]	SLOTB_PERIOD[7:0]										
0x37	ALT_PWR_DN	[15:8]	CH34_DISABLE[15:13]			CH2_DISABLE[12:10]			SLOTB_PERIOD[9:8]			0x0000	R/W
		[7:0]	Reserved						SLOTA_PERIOD[9:8]				
0x38	EXT_SYNC_STARTUP	[15:8]	EXT_SYNC_STARTUP[15:8]									0x0000	R/W
		[7:0]	EXT_SYNC_STARTUP[7:0]										
0x39	SLOTA_AFE_WINDOW	[15:8]	SLOTA_AFE_WIDTH[4:0]				SLOTA_AFE_OFFSET[10:8]					0x22FC	R/W
		[7:0]	SLOTA_AFE_OFFSET[7:0]										
0x3B	SLOTB_AFE_WINDOW	[15:8]	SLOTB_AFE_WIDTH[4:0]				SLOTB_AFE_OFFSET[10:8]					0x22FC	R/W
		[7:0]	SLOTB_AFE_OFFSET[7:0]										
0x3C	AFE_PWR_CFG1	[15:8]	Reserved		Reserved			Reserved	V_CATHODE	AFE_POWER-DOWN[5]	0x3006	R/W	
		[7:0]	AFE_POWERDOWN[4:0]						Reserved				
0x3E	SLOTA_FLOAT_LED	[15:8]	FLT_LED_SELECT_A[1:0]		Reserved		FLT_LED_WIDTH_A[4:0]				0x0320	R/W	
		[7:0]	FLT_LED_OFFSET_A[7:0]										
0x3F	SLOTB_FLOAT_LED	[15:8]	FLT_LED_SELECT_B[1:0]		Reserved		FLT_LED_WIDTH_B[4:0]				0x0320	R/W	
		[7:0]	FLT_LED_OFFSET_B[7:0]										
0x42	SLOTA_TIA_CFG	[15:8]	SLOTA_AFE_MODE[5:0]						SLOTA_BUF_GAIN	Reserved		0x1C38	R/W
		[7:0]	SLOTA_INT_AS_BUF	SLOTA_TIA_IND_EN	SLOTA_TIA_VREF[1:0]			Reserved (write 0x1)		SLOTA_TIA_GAIN[1:0]			
0x43	SLOTA_AFE_CFG	[15:8]	SLOTA_AFE_CFG[15:8]									0xADA5	R/W
		[7:0]	SLOTA_AFE_CFG[7:0]										
0x44	SLOTB_TIA_CFG	[15:8]	SLOTB_AFE_MODE[5:0]						SLOTB_BUF_GAIN	Reserved		0x1C38	R/W
		[7:0]	SLOTB_INT_AS_BUF	SLOTB_TIA_IND_EN	SLOTB_TIA_VREF[1:0]			Reserved (write 0x1)		SLOTB_TIA_GAIN[1:0]			
0x45	SLOTB_AFE_CFG	[15:8]	SLOTB_AFE_CFG[15:8]									0xADA5	R/W
		[7:0]	SLOTB_AFE_CFG[7:0]										
0x4B	SAMPLE_CLK	[15:8]	Reserved								CLK32K_BYP	0x2612	R/W
		[7:0]	CLK32K_EN	Reserved		CLK32K_ADJUST[5:0]							

Hex. Addr.	Name	Bits	Bit 15	Bit 14	Bit 13	Bit 12	Bit 11	Bit 10	Bit 9	Bit 8	Reset	R/W	
			Bit 7	Bit 6	Bit 5	Bit 4	Bit 3	Bit 2	Bit 1	Bit 0			
0x4D	CLK32M_ADJUST	[15:8]	Reserved									0x0098	R/W
		[7:0]	CLK32M_ADJUST[7:0]										
0x4F	EXT_SYNC_SEL	[15:8]	Reserved									0x2090	R/W
		[7:0]	Reserved	GPIO1_OE	GPIO1_IE	Reserved	EXT_SYNC_SEL[1:0]		GPIO0_IE	Reserved			
0x50	CLK32M_CAL_EN	[15:8]	Reserved									0x0000	R/W
		[7:0]	Reserved	GPIO1_CTRL	CLK32M_CAL_EN	Reserved							
0x54	AFE_PWR_CFG2	[15:8]	Reserved		SLEEP_V_CATHODE[1:0]		SLOTB_V_CATHODE[1:0]		SLOTA_V_CATHODE[1:0]		0x0020	R/W	
		[7:0]	REG54_VCAT_ENABLE	Reserved									
0x55	TIA_INDEP_GAIN	[15:8]	Reserved				SLOTB_TIA_GAIN_4[1:0]		SLOTB_TIA_GAIN_3[1:0]		0x0000	R/W	
		[7:0]	SLOTB_TIA_GAIN_2[1:0]		SLOTA_TIA_GAIN_4[1:0]		SLOTA_TIA_GAIN_3[1:0]		SLOTA_TIA_GAIN_2[1:0]				
0x58	Math	[15:8]	Reserved				FLT_MATH34_B[1:0]		FLT_MATH34_A[1:0]		0x0000	R/W	
		[7:0]	ENA_INT_AS_BUF	FLT_MATH12_B[1:0]		Reserved	Reserved	FLT_MATH12_A[1:0]		Reserved			
0x59	FLT_CONFIG_B	[15:8]	Reserved	FLT_EN_B[1:0]		FLT_PRECON_B[4:0]				0x0808	R/W		
		[7:0]	Reserved										
0x5A	FLT_LED_FIRE	[15:8]	FLT_LED_FIRE_B[3:0]				FLT_LED_FIRE_A[3:0]				0x0010	R/W	
		[7:0]	Reserved (write 0x10)										
0x5E	FLT_CONFIG_A	[15:8]	Reserved	FLT_EN_A[1:0]		FLT_PRECON_A[4:0]				0x0808	R/W		
		[7:0]	Reserved										
0x5F	DATA_ACCESS_CTL	[15:8]	Reserved									0x0000	R/W
		[7:0]	Reserved					SLOTB_DATA_HOLD	SLOTA_DATA_HOLD	DIGITAL_CLOCK_ENA			
0x60	FIFO_ACCESS	[15:8]	FIFO_DATA[15:8]									0x0000	R
		[7:0]	FIFO_DATA[7:0]										
0x64	SLOTA_PD1_16BIT	[15:8]	SLOTA_CH1_16BIT[15:8]									0x0000	R
		[7:0]	SLOTA_CH1_16BIT[7:0]										
0x65	SLOTA_PD2_16BIT	[15:8]	SLOTA_CH2_16BIT[15:8]									0x0000	R
		[7:0]	SLOTA_CH2_16BIT[7:0]										
0x66	SLOTA_PD3_16BIT	[15:8]	SLOTA_CH3_16BIT[15:8]									0x0000	R
		[7:0]	SLOTA_CH3_16BIT[7:0]										
0x67	SLOTA_PD4_16BIT	[15:8]	SLOTA_CH4_16BIT[15:8]									0x0000	R
		[7:0]	SLOTA_CH4_16BIT[7:0]										
0x68	SLOTB_PD1_16BIT	[15:8]	SLOTB_CH1_16BIT[15:8]									0x0000	R
		[7:0]	SLOTB_CH1_16BIT[7:0]										
0x69	SLOTB_PD2_16BIT	[15:8]	SLOTB_CH2_16BIT[15:8]									0x0000	R
		[7:0]	SLOTB_CH2_16BIT[7:0]										
0x6A	SLOTB_PD3_16BIT	[15:8]	SLOTB_CH3_16BIT[15:8]									0x0000	R
		[7:0]	SLOTB_CH3_16BIT[7:0]										
0x6B	SLOTB_PD4_16BIT	[15:8]	SLOTB_CH4_16BIT[15:8]									0x0000	R
		[7:0]	SLOTB_CH4_16BIT[7:0]										
0x70	A_PD1_LOW	[15:8]	SLOTA_CH1_LOW[15:8]									0x0000	R
		[7:0]	SLOTA_CH1_LOW[7:0]										
0x71	A_PD2_LOW	[15:8]	SLOTA_CH2_LOW[15:8]									0x0000	R
		[7:0]	SLOTA_CH2_LOW[7:0]										
0x72	A_PD3_LOW	[15:8]	SLOTA_CH3_LOW[15:8]									0x0000	R
		[7:0]	SLOTA_CH3_LOW[7:0]										
0x73	A_PD4_LOW	[15:8]	SLOTA_CH4_LOW[15:8]									0x0000	R
		[7:0]	SLOTA_CH4_LOW[7:0]										
0x74	A_PD1_HIGH	[15:8]	SLOTA_CH1_HIGH[15:8]									0x0000	R
		[7:0]	SLOTA_CH1_HIGH[7:0]										
0x75	A_PD2_HIGH	[15:8]	SLOTA_CH2_HIGH[15:8]									0x0000	R
		[7:0]	SLOTA_CH2_HIGH[7:0]										
0x76	A_PD3_HIGH	[15:8]	SLOTA_CH3_HIGH[15:8]									0x0000	R
		[7:0]	SLOTA_CH3_HIGH[7:0]										
0x77	A_PD4_HIGH	[15:8]	SLOTA_CH4_HIGH[15:8]									0x0000	R
		[7:0]	SLOTA_CH4_HIGH[7:0]										

Hex. Addr.	Name	Bits	Bit 15	Bit 14	Bit 13	Bit 12	Bit 11	Bit 10	Bit 9	Bit 8	Reset	R/W		
			Bit 7	Bit 6	Bit 5	Bit 4	Bit 3	Bit 2	Bit 1	Bit 0				
0x78	B_PD1_LOW	[15:8]	SLOTB_CH1_LOW[15:8]										0x0000	R
		[7:0]	SLOTB_CH1_LOW[7:0]											
0x79	B_PD2_LOW	[15:8]	SLOTB_CH2_LOW[15:8]										0x0000	R
		[7:0]	SLOTB_CH2_LOW[7:0]											
0x7A	B_PD3_LOW	[15:8]	SLOTB_CH3_LOW[15:8]										0x0000	R
		[7:0]	SLOTB_CH3_LOW[7:0]											
0x7B	B_PD4_LOW	[15:8]	SLOTB_CH4_LOW[15:8]										0x0000	R
		[7:0]	SLOTB_CH4_LOW[7:0]											
0x7C	B_PD1_HIGH	[15:8]	SLOTB_CH1_HIGH[15:8]										0x0000	R
		[7:0]	SLOTB_CH1_HIGH[7:0]											
0x7D	B_PD2_HIGH	[15:8]	SLOTB_CH2_HIGH[15:8]										0x0000	R
		[7:0]	SLOTB_CH2_HIGH[7:0]											
0x7E	B_PD3_HIGH	[15:8]	SLOTB_CH3_HIGH[15:8]										0x0000	R
		[7:0]	SLOTB_CH3_HIGH[7:0]											
0x7F	B_PD4_HIGH	[15:8]	SLOTB_CH4_HIGH[15:8]										0x0000	R
		[7:0]	SLOTB_CH4_HIGH[7:0]											

LED CONTROL REGISTERS

Table 27. LED Control Registers

Address	Data Bit	Default Value	Access	Name	Description
0x14	[15:12]	0x0	R/W	Reserved	Write 0x0 to these bits for proper operation.
	[11:8]	0x5	R/W	SLOTB_PD_SEL	PDx connection selection for Time Slot B. See the Time Slot Switch section for detailed descriptions.
	[7:4]	0x4	R/W	SLOTA_PD_SEL	PDx connection selection for Time Slot A. See the Time Slot Switch section for detailed descriptions.
	[3:2]	0x0	R/W	SLOTB_LED_SEL	Time Slot B LED configuration. These bits determine which LED is associated with Time Slot B. 0x0: pulse PDx connection to AFE. Float mode and pulse connect mode enable. 0x1: LEDX1 pulses during Time Slot B. 0x2: LEDX2 pulses during Time Slot B. 0x3: LEDX3 pulses during Time Slot B.
	[1:0]	0x1	R/W	SLOTA_LED_SEL	Time Slot A LED configuration. These bits determine which LED is associated with Time Slot A. 0x0: pulse PDx connection to AFE. Float mode and pulse connect mode enable. 0x1: LEDX1 pulses during Time Slot A. 0x2: LEDX2 pulses during Time Slot A. 0x3: LEDX3 pulses during Time Slot A.
0x22	[15:14]	0x0	R/W	Reserved	Write 0x0.
	13	0x1	R/W	ILED3_SCALE	LEDX3 current scale factor. 1: 100% strength. 0: 10% strength; sets the LEDX3 driver in low power mode. $LEDX3 \text{ Current Scale} = 0.1 + 0.9 \times (\text{Register } 0x22, \text{ Bit } 13)$.
	12	0x1	R/W	Reserved	Write 0x1.
	[11:7]	0x0	R/W	Reserved	Write 0x0.
	[6:4]	0x0	R/W	ILED3_SLEW	LEDX3 driver slew rate control. The slower the slew rate, the safer the performance in terms of reducing the risk of overvoltage of the LED driver. 0x0: the slowest slew rate. ... 0x7: the fastest slew rate.
	[3:0]	0x0	R/W	ILED3_COARSE	LEDX3 coarse current setting. Coarse current sink target value of LEDX3 in standard operation. 0x0: lowest coarse setting. ... 0xF: highest coarse setting. $LED3_{PEAK} = LED3_{COARSE} \times LED3_{FINE} \times LED3_{SCALE}$ where: $LED3_{PEAK}$ is the LEDX3 peak target value (mA). $LED3_{COARSE} = 50.3 + 19.8 \times (\text{Register } 0x22, \text{ Bits}[3:0])$. $LED3_{FINE} = 0.74 + 0.022 \times (\text{Register } 0x25, \text{ Bits}[15:11])$. $LED3_{SCALE} = 0.1 + 0.9 \times (\text{Register } 0x22, \text{ Bit } 13)$.
0x23	[15:14]	0x0	R/W	Reserved	Write 0x0.
	13	0x1	R/W	ILED1_SCALE	LEDX1 current scale factor. 1: 100% strength. 0: 10% strength; sets the LEDX1 driver in low power mode. $LEDX1 \text{ Current Scale} = 0.1 + 0.9 \times (\text{Register } 0x23, \text{ Bit } 13)$.
	12	0x1	R/W	Reserved	Write 0x1.
	[11:7]	0x0	R/W	Reserved	Write 0x0.

Address	Data Bit	Default Value	Access	Name	Description
	[6:4]	0x0	R/W	ILED1_SLEW	LEDX1 driver slew rate control. The slower the slew rate, the safer the performance in terms of reducing the risk of overvoltage of the LED driver. 0: the slowest slew rate. ... 7: the fastest slew rate.
	[3:0]	0x0	R/W	ILED1_COARSE	LEDX1 coarse current setting. Coarse current sink target value of LEDX1 in standard operation. 0x0: lowest coarse setting. ... 0xF: highest coarse setting. $LED1_{PEAK} = LED1_{COARSE} \times LED1_{FINE} \times LED1_{SCALE}$ where: $LED1_{PEAK}$ is the LEDX1 peak target value (mA). $LED1_{COARSE} = 50.3 + 19.8 \times (\text{Register } 0x23, \text{ Bits}[3:0])$. $LED1_{FINE} = 0.74 + 0.022 \times (\text{Register } 0x25, \text{ Bits}[4:0])$. $LED1_{SCALE} = 0.1 + 0.9 \times (\text{Register } 0x23, \text{ Bit } 13)$.
0x24	[15:14]	0x0	R/W	Reserved	Write 0x0.
	13	0x1	R/W	ILED2_SCALE	LEDX2 current scale factor. 1: 100% strength. 0: 40% strength; sets the LEDX2 driver in low power mode. $LED2 \text{ Current Scale} = 0.1 + 0.9 \times (\text{Register } 0x24, \text{ Bit } 13)$
	12	0x1	R/W	Reserved	Write 0x1.
	[11:7]	0x0	R/W	Reserved	Write 0x0.
	[6:4]	0x0	R/W	ILED2_SLEW	LEDX2 driver slew rate control. The slower the slew rate, the safer the performance in terms of reducing the risk of overvoltage of the LED driver. 0: the slowest slew rate. ... 7: the fastest slew rate.
	[3:0]	0x0	R/W	ILED2_COARSE	LEDX2 coarse current setting. Coarse current sink target value of LEDX2 in standard operation. 0x0: lowest coarse setting. ... 0xF: highest coarse setting. $LED2_{PEAK} = LED2_{COARSE} \times LED2_{FINE} \times LED2_{SCALE}$ where: $LED2_{PEAK}$ is the LEDX2 peak target value (mA). $LED2_{COARSE} = 50.3 + 19.8 \times (\text{Register } 0x24, \text{ Bits}[3:0])$. $LED2_{FINE} = 0.74 + 0.022 \times (\text{Register } 0x25, \text{ Bits}[10:6])$. $LED2_{SCALE} = 0.1 + 0.9 \times (\text{Register } 0x24, \text{ Bit } 13)$.
0x25	[15:11]	0xC	R/W	ILED3_FINE	LEDX3 fine adjust. Current adjust multiplier for LED3. $LEDX3 \text{ fine adjust} = 0.74 + 0.022 \times (\text{Register } 0x25, \text{ Bits}[15:11])$. See Register 0x22, Bits[3:0], for the full LED3 formula.
	[10:6]	0xC	R/W	ILED2_FINE	LEDX2 fine adjust. Current adjust multiplier for LED2. $LEDX2 \text{ fine adjust} = 0.74 + 0.022 \times (\text{Register } 0x25, \text{ Bits}[10:6])$. See Register 0x24, Bits[3:0], for the full LED2 formula.
	5	0x0	R/W	Reserved	Write 0x0.
	[4:0]	0xC	R/W	ILED1_FINE	LEDX1 fine adjust. Current adjust multiplier for LED1. $LEDX1 \text{ Fine Adjust} = 0.74 + 0.022 \times (\text{Register } 0x25, \text{ Bits}[4:0])$. See Register 0x23, Bits[3:0], for the full LED1 formula.
0x30	[15:13]	0x0	R/W	Reserved	Write 0x0.
	[12:8]	0x3	R/W	SLOTA_LED_WIDTH	LED pulse width (in 1 μ s step) for Time Slot A.
	[7:0]	0x20	R/W	SLOTA_LED_OFFSET	LED offset width (in 1 μ s step) for Time Slot A.

Address	Data Bit	Default Value	Access	Name	Description
0x31	[15:8]	0x08	R/W	SLOTA_PULSES	LED Time Slot A pulse count. n_A : number of LED pulses in Time Slot A.
	[7:0]	0x18	R/W	SLOTA_PERIOD	8 LSBs of LED Time Slot A pulse period (in 1 μ s step).
0x34	[15:10]	0x00	R/W	Reserved	Write 0x0.
	9	0x0	R/W	SLOTB_LED_DIS	Time Slot B LED disable. 1: disables the LED assigned to Time Slot B. Register 0x34 keeps the drivers active and prevents them from pulsing current to the LEDs. Disabling both LEDs via this register is often used to measure the dark level. Use Register 0x11 instead to enable or disable the actual time slot usage and not only the LED.
	8	0x0	R/W	SLOTA_LED_DIS	Time Slot A LED disable. 1: disables the LED assigned to Time Slot A. Use Register 0x11 instead to enable or disable the actual time slot usage and not only the LED.
	[7:0]	0x00	R/W	Reserved	Write 0x00.
0x35	[15:13]	0x0	R/W	Reserved	Write 0x0.
	[12:8]	0x3		SLOTB_LED_WIDTH	LED pulse width (in 1 μ s step) for Time Slot B.
	[7:0]	0x20		SLOTB_LED_OFFSET	LED offset width (in 1 μ s step) for Time Slot B.
0x36	[15:8]	0x08	R/W	SLOTB_PULSES	LED Time Slot B pulse count. n_B : number of LED pulses in Time Slot B.
	[7:0]	0x18	R/W	SLOTB_PERIOD	8 LSBs of LED Time Slot B pulse period (in 1 μ s step).

AFE CONFIGURATION REGISTERS

Table 28. AFE Global Configuration Registers

Address	Data Bit	Default Value	Access	Name	Description
0x37	[15:13]	0x0	R/W	CH34_DISABLE	Power-down options for Channel 3 and Channel 4 only. Bit 13: power down Channel 3, Channel 4 TIA op amp. Bit 14: power down Channel 3, Channel 4 BPF op amp. Bit 15: power down Channel 3, Channel 4 integrator op amp.
	[12:10]	0x0	R/W	CH2_DISABLE	Bit 10: power down Channel 2 TIA op amp. Bit 11: power down Channel 2 BPF op amp. Bit 12: power down Channel 2 integrator op amp.
	[9:8]	0x0	R/W	SLOTB_PERIOD	8 MSBs of LED Time Slot B pulse period.
	[7:2]	0x00	R/W	Reserved	Write 0x00
	[1:0]	0x0	R/W	SLOTA_PERIOD	8 MSBs of LED Time Slot A pulse period.
0x3C	[15:14]	0x0	R/W	Reserved	Write 0x0.
	[13:11]	0x6	R/W	Reserved	Write 0x6.
	10	0x0	R/W	Reserved	Reserved.
	9	0x0	R/W	V_CATHODE	0x0: 1.3 V (identical to anode voltage). 0x1: 1.8 V (reverse bias photodiode by 550 mV). This setting may add noise.
	[8:3]	0x00	R/W	AFE_POWERDOWN	AFE channels power-down select. 0x0: keeps all channels on. Bit 3: power down Channel 1 TIA op amp. Bit 4: power down Channel 1 BPF op amp. Bit 5: power down Channel 1 integrator op amp. Bit 6: power down Channel 2, Channel 3, and Channel 4 TIA op amp. Bit 7: power down Channel 2, Channel 3, and Channel 4 BPF op amp. Bit 8: power down Channel 2, Channel 3, and Channel 4 integrator op amp.
	[2:0]	0x6	R/W	Reserved	Write 0x6.

Address	Data Bit	Default Value	Access	Name	Description
0x54	[15:14]	0x0	R/W	Reserved	Write 0x0.
	[13:12]	0x0	R/W	SLEEP_V_CATHODE	If Bit 7 = 1; this setting is applied to the cathode voltage while the device is in sleep mode. 0x0: V _{DD} . 0x1: AFE VREF during idle, V _{DD} during sleep. 0x2: floating. 0x3: 0.0 V.
	[11:10]	0x0	R/W	SLOTB_V_CATHODE	If Bit 7 = 1; this setting is applied to the cathode voltage while the device is in Time Slot B operation. The anode voltage is determined by Register 0x44, Bits[5:4]. 0x0: V _{DD} (1.8 V). 0x1: equal to PD anode voltage. 0x2: sets a reverse PD bias of ~250 mV (recommended setting). 0x3: 0.0 V (this forward biases a diode at the input).
	[9:8]	0x0	R/W	SLOTA_V_CATHODE	If Bit 7 = 1; this setting is applied to the cathode voltage while the device is in Time Slot A operation. The anode voltage is determined by Register 0x42, Bits[5:4]. 0x0: V _{DD} (1.8 V). 0x1: equal to PD anode voltage. 0x2: sets a reverse PD bias of ~250 mV (recommended setting). 0x3: 0.0 V (this forward biases a diode at the input).
	7	0x0	R/W	REG54_VCAT_ENABLE	0: use the cathode voltage settings defined by Register 0x3C, Bit 9. 1: override Register 0x3C, Bit 9 with cathode settings defined by Register 0x54, Bits[13:8].
	[6:0]	0x20	R/W	Reserved	Reserved.
0x55	[15:12]	0x0	R/W	Reserved	Write 0x0.
	[11:10]	0x0	R/W	SLOTB_TIA_GAIN_4	TIA gain for Time Slot B, Channel 4 when Register 0x44, Bit 6 = 1. 0: 200 kΩ. 1: 100 kΩ. 2: 50 kΩ. 3: 25 kΩ.
	[9:8]	0x0	R/W	SLOTB_TIA_GAIN_3	TIA gain for Time Slot B, Channel 3 when Register 0x44, Bit 6 = 1. 0: 200 kΩ 1: 100 kΩ. 2: 50 kΩ. 3: 25 kΩ.
	[7:6]	0x0	R/W	SLOTB_TIA_GAIN_2	TIA gain for Time Slot B, Channel 2 when Register 0x44, Bit 6 = 1. 0: 200 kΩ 1: 100 kΩ. 2: 50 kΩ. 3: 25 kΩ.
	[5:4]	0x0	R/W	SLOTA_TIA_GAIN_4	TIA gain for Time Slot A, Channel 4 when Register 0x42, Bit 6 = 1. 0: 200 kΩ 1: 100 kΩ. 2: 50 kΩ. 3: 25 kΩ.

Address	Data Bit	Default Value	Access	Name	Description
	[3:2]	0x0	R/W	SLOTA_TIA_GAIN_3	TIA gain for Time Slot A, Channel 3 when Register 0x42, Bit 6 = 1. 0: 200 kΩ. 1: 100 kΩ. 2: 50 kΩ. 3: 25 kΩ.
	[1:0]	0x0	R/W	SLOTA_TIA_GAIN_2	TIA gain for Time Slot A, Channel 2 when Register 0x42, Bit 6 = 1. 0: 200 kΩ. 1: 100 kΩ. 2: 50 kΩ. 3: 25 kΩ.

Table 29. AFE Configuration Registers, Time Slot A

Address	Data Bit	Default Value	Access	Name	Description
0x17	[15:4]	0x000	R/W	Reserved	Write 0x000
	[3:0]	0x0	R/W	INTEG_ORDER_A	Integration sequence order for Time Slot A. Each bit corresponds to the polarity of the integration sequence of a single pulse in a four-pulse sequence. Bit 0 controls the integration sequence of Pulse 1, Bit 1 controls Pulse 2, Bit 2 controls Pulse 3, and Bit 3 controls Pulse 4. After four pulses, the sequence repeats. 0: normal integration sequence. 1: reversed integration sequence.
0x39	[15:11]	0x4	R/W	SLOTA_AFE_WIDTH	AFE integration window width (in 1 μs step) for Time Slot A.
	[10:0]	0x2FC	R/W	SLOTA_AFE_OFFSET	AFE integration window offset for Time Slot A in 31.25 ns steps.
0x42	[15:10]	0x07	R/W	SLOTA_AFE_MODE	Set to 0x07.
	9	0x0	R/W	SLOTA_BUF_GAIN	0: integrator as buffer gain = 1. 1: integrator as buffer gain = 0.7.
	8	0x0	R/W	Reserved	Set to 0.
	7	0x0	R/W	SLOTA_INT_AS_BUF	0: normal integrator configuration. 1: converts integrator to buffer amplifier (used in TIA ADC mode only).
	6	0x0	R/W	SLOTA_TIA_IND_EN	Enable Time Slot A TIA gain individual settings. When it is enabled, the Channel 1 TIA gain is set via Register 0x42, Bits[1:0], and the Channel 2 through Channel 4 TIA gain is set via Register 0x55, Bits[5:0]. 0: disable TIA gain individual setting. 1: enable TIA gain individual setting.
	[5:4]	0x3	R/W	SLOTA_TIA_VREF	Set V _{REF} of the TIA for Time Slot A. 0: 1.14 V. 1: 1.01 V. 2: 0.90 V. 3: 1.27 V (default recommended).
	[3:2]	0x2	R/W	Reserved	Reserved. Write 0x1.
	[1:0]	0x0	R/W	SLOTA_TIA_GAIN	Transimpedance amplifier gain for Time Slot A. When SLOTA_TIA_IND_EN is enabled, this value is for Time Slot B, Channel 1 TIA gain. When SLOTA_TIA_IND_EN is disabled, it is for all four Time Slot A channel TIA gain settings. 0: 200 kΩ. 1: 100 kΩ. 2: 50 kΩ. 3: 25 kΩ.

Address	Data Bit	Default Value	Access	Name	Description
0x43	[15:0]	0xADA5	R/W	SLOTA_AFE_CFG	AFE connection in Time Slot A. 0xADA5: analog full path mode (TIA→BPF→INT→ADC). 0xAE65: TIA ADC mode (must set Register 0x42, Bit 7 = 1 and Register 0x58, Bit 7 = 1). 0xB065: TIA ADC mode (if Register 0x42, Bit 7 = 0). Others: reserved.

Table 30. AFE Configuration Registers, Time Slot B

Address	Data Bit	Default Value	Access	Name	Description
0x1D	[15:4]	0x000	R/W	Reserved	Write 0x000
	[3:0]	0x0	R/W	INTEG_ORDER_B	Integration sequence order for Time Slot B. Each bit corresponds to the polarity of the integration sequence of a single pulse in a four-pulse sequence. Bit 0 controls the integration sequence of Pulse 1, Bit 1 controls Pulse 2, Bit 2 controls Pulse 3, and Bit 3 controls Pulse 4. After four pulses, the sequence repeats. 0: normal integration sequence. 1: reversed integration sequence
0x3B	[15:11]	0x04	R/W	SLOTB_AFE_WIDTH	AFE integration window width (in 1 μ s step) for Time Slot B.
	[10:0]	0x17	R/W	SLOTB_AFE_OFFSET	AFE integration window offset for Time Slot B in 31.25 ns steps.
0x44	[15:10]	0x07	R/W	SLOTB_AFE_MODE	Set to 0x07.
	9	0x0	R/W	SLOTB_BUF_GAIN	0: integrator as buffer gain = 1. 1: integrator as buffer gain = 0.7.
	8	0x0	R/W	Reserved	Set to 0.
	7	0x0	R/W	SLOTB_INT_AS_BUF	0: normal integrator configuration. 1: convert integrator to buffer amplifier (used in TIA ADC mode only).
	6	0x0	R/W	SLOTB_TIA_IND_EN	Enable Time Slot B TIA gain individual settings. When it is enabled, the Channel 1 TIA gain is set via Register 0x44, Bits[1:0], and the Channel 2 through Channel 4 TIA gain is set via Register 0x55, Bits[11:6]. 0: disable TIA gain individual setting. 1: enable TIA gain individual setting.
	[5:4]	0x3	R/W	SLOTB_TIA_VREF	Set VREF of the TIA for Time Slot B. 0: 1.14 V. 1: 1.01 V. 2: 0.90 V. 3: 1.27 V (default recommended).
	[3:2]	0x2	R/W	Reserved	Write 0x1.
	[1:0]	0x0	R/W	SLOTB_TIA_GAIN	Transimpedance amplifier gain for Time Slot B. When SLOTB_TIA_IND_EN is enabled, this value is for Time Slot B, Channel 1 TIA gain. When SLOTB_TIA_IND_EN is disabled, it is for all four Time Slot B channel TIA gain settings. 0: 200 k Ω . 1: 100 k Ω . 2: 50 k Ω . 3: 25 k Ω .
0x45	[15:0]	0xADA5	R/W	SLOTB_AFE_CFG	AFE connection in Time Slot B. 0xADA5: analog full path mode (TIA→BPF→INT→ADC). 0xAE65: TIA ADC mode (must set Register 0x44, Bit 7 = 1 and Register 0x58, Bit 7 = 1). 0xB065: TIA ADC mode (if Register 0x44, Bit 7 = 0). Others: reserved.

FLOAT MODE REGISTERS

Table 31. Float Mode Registers

Address	Data Bit	Default Value	Access	Name	Description
0x04	[15:8]	0x0	R	Reserved	Not applicable.
	[7:4]	0x0	R	BG_STATUS_B	Status of comparison between background light level and background threshold value for Time Slot B (BG_THRESH_B). A 1 in any bit location means the threshold has been crossed BG_COUNT_B number of times. This register is cleared once it is read. Bit 4: Time Slot B, Channel 1 exceeded threshold count. Bit 5: Time Slot B, Channel 2 exceeded threshold count. Bit 6: Time Slot B, Channel 3 exceeded threshold count. Bit 7: Time Slot B, Channel 4 exceeded threshold count.
	[3:0]	0x0	R	BG_STATUS_A	Status of comparison between background light level and background threshold value for Time Slot A (BG_THRESH_A). A 1 in any bit location means the threshold has been crossed BG_COUNT_A number of times. This register is cleared once it is read. Bit 0: Time Slot A, Channel 1 exceeded threshold count. Bit 1: Time Slot A, Channel 2 exceeded threshold count. Bit 2: Time Slot A, Channel 3 exceeded threshold count. Bit 3: Time Slot A, Channel 4 exceeded threshold count.
0x16	[15:14]	0x0	R/W	BG_COUNT_A	For Time Slot A, this is the number of times the ADC value exceeds the BG_THRESH_A value during the float mode subtract cycles before the BG_STATUS_A bit is set. 0: never set BG_STATUS_A. 1: set when BG_THRESH_A is exceeded 1 time. 2: set when BG_THRESH_A is exceeded 4 times. 3: set when BG_THRESH_A is exceeded 16 times.
	[13:0]	0x0	R/W	BG_THRESH_A	The background threshold for Time Slot A that is compared against the ADC result during the subtract cycles during float mode. If the ADC result exceeds the value in this register, BG_COUNT_A is incremented.
0x1C	[15:14]	0x0	R/W	BG_COUNT_B	For Time Slot B, this is the number of times the ADC value exceeds the BG_THRESH_B value during the float mode subtract cycles before the BG_STATUS_B bit is set. 0: never set BG_STATUS_B. 1: set when BG_THRESH_B is exceeded 1 time. 2: set when BG_THRESH_B is exceeded 4 times. 3: set when BG_THRESH_B is exceeded 16 times.
	[13:0]	0x0	R/W	BG_THRESH_B	The background threshold for Time Slot B that is compared against the ADC result during the subtract cycles during float mode. If the ADC result exceeds the value in this register, BG_COUNT_B is incremented.
0x3E	[15:14]	0x0	R/W	FLT_LED_SELECT_A	Time Slot A LED selection for float LED mode. 0: no LED selected. 1: LED1. 2: LED2. 3: LED3.
	13	0	R/W	Reserved	Write 0x0.
	[12:8]	0x03	R/W	FLT_LED_WIDTH_A	Time Slot A LED pulse width for LED float mode in 1 μ s steps.
	[7:0]	0x20	R/W	FLT_LED_OFFSET_A	Time to first LED pulse in float mode for Time Slot A.

Address	Data Bit	Default Value	Access	Name	Description
0x3F	[15:14]	0x0	R/W	FLT_LED_SELECT_B	Time Slot B LED selection for float LED mode. 0: no LED selected. 1: LED1. 2: LED2. 3: LED3.
	13	0	R/W	Reserved	Write 0x0.
	[12:8]	0x03	R/W	FLT_LED_WIDTH_B	Time Slot B LED pulse width for LED float mode in 1 μ s steps.
	[7:0]	0x20	R/W	FLT_LED_OFFSET_B	Time to first LED pulse in Float mode for Time Slot A.
0x58	[15:12]	0x0	R/W	Reserved	Reserved.
	[11:10]	0x0	R/W	FLT_MATH34_B	Time Slot B control for adding and subtracting Sample 3 and Sample 4 in a four-pulse sequence (or any multiple of four pulses, for example, Sample 15 and Sample 16 in a 16-pulse sequence). 00: add third and fourth. 01: add third and subtract fourth. 10: subtract third and add fourth. 11: subtract third and fourth.
	[9:8]	0x0	R/W	FLT_MATH34_A	Time Slot A control for adding and subtracting Sample 3 and Sample 4 in a four-pulse sequence (or any multiple of four pulses, for example, Sample 15 and Sample 16 in a 16-pulse sequence). 00: add third and fourth. 01: add third and subtract fourth. 10: subtract third and add fourth. 11: subtract third and fourth.
	7	0x0	R/W	ENA_INT_AS_BUF	Set to 1 to enable the configuration of the integrator as a buffer in TIA ADC mode.
	[6:5]	0x0	R/W	FLT_MATH12_B	Time Slot B control for adding and subtracting Sample 1 and Sample 2 in a four-pulse sequence (or any multiple of four pulses, for example, Sample 13 and Sample 14 in a 16-pulse sequence). 00: add first and second. 01: add first and subtract second. 10: subtract first and add second. 11: subtract first and second.
	[4:3]	0x0	R/W	Reserved	Write 0x0.
	[2:1]	0x0	R/W	FLT_MATH12_A	Time Slot A control for adding and subtracting Sample 1 and Sample 2 in a four-pulse sequence (or any multiple of four pulses, for example, Sample 13 and Sample 14 in a 16-pulse sequence). 00: add first and second. 01: add first and subtract second. 10: subtract first and add second. 11: subtract first and second.
	0	0x0	R/W	Reserved	Write 0x0.
0x59	15	0x0	R/W	Reserved	Write 0x0.
	[14:13]	0x0	R/W	FLT_EN_B	0: default setting, float disabled for Time Slot B. 1: reserved. 2: reserved. 3: enable float mode.
	[12:8]	0x08	R/W	FLT_PRECON_B	Float mode preconditioning time for Time Slot B. Time to start of first float time, which is typically 16 μ s.
	[7:0]	0x08	R/W	Reserved	Write 0x08.

Address	Data Bit	Default Value	Access	Name	Description
0x5A	[15:12]	0x0	R/W	FLT_LED_FIRE_B	In any given sequence of four pulses, fire the LED in the selected position by writing a zero into that pulse position. Mask the LED pulse (that is, do not fire LED) by writing a 1 into that position. In a sequence of four pulses on Time Slot B, Register 0x5A, Bit 12, is the first pulse, Bit 13 is the second pulse, Bit 14 is the third pulse, and Bit 15 is the fourth pulse.
	[11:8]	0x0	R/W	FLT_LED_FIRE_A	In any given sequence of four pulses, fire the LED in the selected position by writing a zero into that pulse position. Mask the LED pulse (that is, do not fire LED) by writing a 1 into that position. In a sequence of four pulses on Time Slot A, Register 0x5A, Bit 8, is the first pulse, Bit 9 is the second pulse, Bit 10 is the third pulse, and Bit 11 is the fourth pulse.
	[7:0]	0x10	R/W	Reserved	Write 0x10.
0x5E	15	0x0	R/W	Reserved	Write 0x0.
	[14:13]	0x0	R/W	FLT_EN_A	0: default setting, float disabled for Time Slot A. 1: reserved 2: reserved 3: enable float mode in Time Slot A.
	[12:8]	0x08	R/W	FLT_PRECON_A	Float mode preconditioning time for Time Slot A. Time to start of first float time, which is typically 16 μ s.
	[7:0]	0x08	R/W	Reserved	Write 0x08.

SYSTEM REGISTERS

Table 32. System Registers

Address	Data Bit	Default Value	Access	Name	Description
0x00	[15:8]	0x00	R/W	FIFO_SAMPLES	FIFO status. Number of available bytes to be read from the FIFO. When comparing this to the FIFO length threshold (Register 0x06, Bits[13:8]), note that the FIFO status value is in bytes and the FIFO length threshold is in words, where one word = two bytes. Write 1 to Bit 15 to clear the contents of the FIFO.
	7	0x0	R/W	Reserved	Write 0x1 to clear this bit to 0x0.
	6	0x0	R/W	SLOTB_INT	Time Slot B interrupt. Describes the type of interrupt event. A 1 indicates an interrupt of a particular event type has occurred. Write a 1 to clear the corresponding interrupt. After clearing, the register goes to 0. Writing a 0 to this register has no effect.
	5	0x0	R/W	SLOTA_INT	Time Slot A interrupt. Describes the type of interrupt event. A 1 indicates an interrupt of a particular event type has occurred. Write a 1 to clear the corresponding interrupt. After clearing, the register goes to 0. Writing a 0 to this register has no effect.
	[4:0]	0x00	R/W	Reserved	Write 0x1F to clear these bits to 0x00.
0x01	[15:9]	0x00	R/W	Reserved	Write 0x00.
	8	0x1	R/W	FIFO_INT_MASK	Sends an interrupt when the FIFO data length has exceeded the FIFO length threshold in Register 0x06, Bits[13:8]. A 0 enables the interrupt.
	7	0x1	R/W	Reserved	Write 0x1.
	6	0x1	R/W	SLOTB_INT_MASK	Sends an interrupt on the Time Slot B sample. Write a 1 to disable the interrupt. Write a 0 to enable the interrupt.
	5	0x1	R/W	SLOTA_INT_MASK	Sends an interrupt on the Time Slot A sample. Write a 1 to disable the interrupt. Write a 0 to enable the interrupt.
	[4:0]	0x1F	R/W	Reserved	Write 0x1F.

Address	Data Bit	Default Value	Access	Name	Description
0x02	[15:10]	0x00	R/W	Reserved	Write 0x0000.
	9	0x0	R/W	GPIO1_DRV	GPIO1 drive. 0: the GPIO1 pin is always driven. 1: the GPIO1 pin is driven when the interrupt is asserted; otherwise, it is left floating and requires a pull-up or pull-down resistor, depending on polarity (operates as open drain). Use this setting if multiple devices must share the GPIO1 pin.
	8	0x0	R/W	GPIO1_POL	GPIO1 polarity. 0: the GPIO1 pin is active high. 1: the GPIO1 pin is active low.
	[7:3]	0x00	R/W	Reserved	Write 0x00.
	2	0x0	R/W	GPIO0_ENA	GPIO0 pin enable. 0: disable the GPIO0 pin. The GPIO0 pin floats, regardless of interrupt status. The status register (Address 0x00) remains active. 1: enable the GPIO0 pin.
	1	0x0	R/W	GPIO0_DRV	GPIO0 drive. 0: the GPIO0 pin is always driven. 1: the GPIO0 pin is driven when the interrupt is asserted; otherwise, it is left floating and requires a pull-up or pull-down resistor, depending on polarity (operates as open drain). Use this setting if multiple devices must share the GPIO0 pin.
	0	0x0	R/W	GPIO0_POL	GPIO0 polarity. 0: the GPIO0 pin is active high. 1: the GPIO0 pin is active low.
0x06	[15:14]	0x0	R/W	Reserved	Write 0x0.
	[13:8]	0x00	R/W	FIFO_THRESH	FIFO length threshold. An interrupt is generated when the number of data-words in the FIFO exceeds the value in FIFO_THRESH. The interrupt pin automatically deasserts when the number of data-words available in the FIFO no longer exceeds the value in FIFO_THRESH.
	[7:0]	0x00	R/W	Reserved	Write 0x00.
0x08	[15:8]	0x09	R	REV_NUM	Revision number.
	[7:0]	0x16	R	DEV_ID	Device ID.
0x09	[15:8]	0x00	W	ADDRESS_WRITE_KEY	Write 0xAD when writing to SLAVE_ADDRESS. Otherwise, do not access.
	[7:1]	0x64	R/W	SLAVE_ADDRESS	I ² C slave address.
	0	0x0	R	Reserved	Do not access.
0x0A	[15:12]	0x0	R	Reserved	Write 0x0.
	[11:0]	0x000	R	CLK_RATIO	When the CLK32M_CAL_EN bit (Register 0x50, Bit 5) is set, the device calculates the number of 32 MHz clock cycles in two cycles of the 32 kHz clock. The result, nominally 2000 (0x07D0), is stored in the CLK_RATIO bits.
0x0B	[15:13]	0x0	R/W	Reserved	Write 0x0.
	[12:8]	0x00	R/W	GPIO1_ALT_CFG	Alternate configuration for the GPIO1 pin. 0x00: GPIO1 is backward compatible to the ADPD103 PDSO pin functionality. 0x01: interrupt function provided on GPIO1, as defined in Register 0x01. 0x02: asserts at the start of the first time slot, deasserts at end of last time slot. 0x05: Time Slot A pulse output. 0x06: Time Slot B pulse output. 0x07: pulse output of both time slots. 0x0C: output data cycle occurred for Time Slot A. 0x0D: output data cycle occurred for Time Slot B. 0x0E: output data cycle occurred.

Address	Data Bit	Default Value	Access	Name	Description
					0x0F: toggles on every sample, which provides a signal at half the sampling rate. 0x10: output = 0. 0x11: output = 1. 0x13: 32 kHz oscillator output. Remaining settings are not supported.
	[7:5]	0x0	R/W	Reserved	Write 0x0.
	[4:0]	0x00	R/W	GPIO0_ALT_CFG	Alternate configuration for the GPIO0 pin. 0x0: GPIO0 is backward compatible to the ADPD103 INT pin functionality. 0x1: interrupt function provided on GPIO0, as defined in Register 0x01. 0x2: asserts at the start of the first time slot, deasserts at end of last time slot. 0x5: Time Slot A pulse output. 0x6: Time Slot B pulse output. 0x7: pulse output of both time slots. 0xC: output data cycle occurred for Time Slot A. 0xD: output data cycle occurred for Time Slot B. 0xE: output data cycle occurred. 0xF: toggles on every sample, which provides a signal at half the sampling rate. 0x10: output = 0. 0x11: output = 1. 0x13: 32 kHz oscillator output. Remaining settings are not supported.
0x0D	[15:0]	0x0000	R/W	SLAVE_ADDRESS_KEY	Enable changing the I ² C address using Register 0x09. 0x04AD: enable address change always. 0x44AD: enable address change if GPIO0 is high. 0x84AD: enable address change if GPIO1 is high. 0xC4AD: enable address change if both GPIO0 and GPIO1 are high.
0x0F	[15:1]	0x0000	R	Reserved	Write 0x0000.
	0	0x0	R/W	SW_RESET	Software reset. Write 0x1 to reset the device. This bit clears itself after a reset. For I ² C communications, this command returns an acknowledge and the device subsequently returns to standby mode with all registers reset to the default state.
0x10	[15:2]	0x0000	R/W	Reserved	Write 0x000.
	[1:0]	0x0	R/W	Mode	Determines the operating mode of the ADPD1080/ADPD1081. 0x0: standby. 0x1: program. 0x2: normal operation.
0x11	[15:14]	0x0	R/W	Reserved	Reserved.
	13	0x0	R/W	RDOUT_MODE	Readback data mode for extended data registers. 0x0: block sum of N samples. 0x1: block average of N samples.
	12	0x1	R/W	FIFO_OVRN_PREVENT	0x0: wrap around FIFO, overwriting old data with new. 0x1: new data if FIFO is not full (recommended setting).
	[11:9]	0x0	R/W	Reserved	Reserved.

Address	Data Bit	Default Value	Access	Name	Description
	[8:6]	0x0	R/W	SLOTB_FIFO_MODE	Time Slot B FIFO data format. 0: no data to FIFO. 1: 16-bit sum of all four channels. 2: 32-bit sum of all four channels. 4: four channels of 16-bit sample data for Time Slot B. 6: four channels of 32-bit extended sample data for Time Slot B. Others: reserved. The selected Time Slot B data is saved in the FIFO. Available only if Time Slot A has the same averaging factor, N (Register 0x15, Bits[10:8] = Bits[6:4]), or if Time Slot A is not saving data to the FIFO (Register 0x11, Bits[4:2] = 0).
	5	0x0	R/W	SLOTB_EN	Time Slot B enable. 1: enables Time Slot B.
	[4:2]	0x0	R/W	SLOTA_FIFO_MODE	Time Slot A FIFO data format. 0: no data to FIFO. 1: 16-bit sum of all four channels. 2: 32-bit sum of all four channels. 4: four channels of 16-bit sample data for Time Slot A. 6: four channels of 32-bit extended sample data for Time Slot A. Others: reserved.
	1	0x0	R/W	Reserved	Write 0x0.
	0	0x0	R/W	SLOTA_EN	Time Slot A enable. 1: enables Time Slot A.
0x38	[15:0]	0x0000	R/W	EXT_SYNC_STARTUP	Write 0x4000 when EXT_SYNC_SEL is 01 or 10. Otherwise, write 0x0.
0x4B	[15:9]	0x13	R/W	Reserved	Write 0x26.
	8	0x0	R/W	CLK32K_BYP	Bypass internal 32 kHz oscillator. 0x0: normal operation. 0x1: provide external clock on the GPIO1 pin. The user must set Register 0x4F, Bits[6:5] = 01 to enable the GPIO1 pin as an input.
	7	0x0	R/W	CLK32K_EN	Sample clock power-up. Enables the data sample clock. 0x0: clock disabled. 0x1: normal operation.
	6	0x0	R/W	Reserved	Write 0x0.
	[5:0]	0x12	R/W	CLK32K_ADJUST	Data sampling (32 kHz) clock frequency adjust. This register is used to calibrate the sample frequency of the device to achieve high precision on the data rate as defined in Register 0x12. Adjusts the sample master 32 kHz clock by 0.6 kHz per LSB. For a 100 Hz sample rate as defined in Register 0x12, 1 LSB of Register 0x4B, Bits[5:0], is 1.9 Hz. Note that a larger value produces a lower frequency. See the Clocks and Timing Calibration section for more information regarding clock adjustment. 00 0000: maximum frequency. 10 0010: typical center frequency. 11 1111: minimum frequency.
0x4D	[15:8]	0x00	R/W	Reserved	Write 0x00.
	[7:0]	0x98	R/W	CLK32M_ADJUST	Internal timing (32 MHz) clock frequency adjust. This register is used to calibrate the internal clock of the device to achieve precisely timed LED pulses. Adjusts the 32 MHz clock by 109 kHz per LSB. See the Clocks and Timing Calibration section for more information regarding clock adjustment. 0000 0000: minimum frequency. 1001 1000: default frequency. 1111 1111: maximum frequency.

Address	Data Bit	Default Value	Access	Name	Description
0x4F	[15:8]	0x20	R/W	Reserved	Write 0x20.
	7	0x1	R/W	Reserved	Write 0x1.
	6	0x0	R/W	GPIO1_OE	GPIO1 pin output enable.
	5	0x0	R/W	GPIO1_IE	GPIO1 pin input enable.
	4	0x1	R/W	Reserved	Write 0x1.
	[3:2]	0x0	R/W	EXT_SYNC_SEL	Sample sync select. 00: use the internal 32 kHz clock with FSAMPLE to select sample timings. 01: use the GPIO0 pin to trigger sample cycle. 10: use the GPIO1 pin to trigger sample cycle. 11: reserved.
	1	0x0	R/W	GPIO0_IE	GPIO0 pin input enable.
	0	0x0	R/W	Reserved	Write 0x0.
0x50	[15:7]	0x000	R/W	Reserved	Write 0x000.
	6	0x0	R/W	GPIO1_CTRL	Controls the GPIO1 output when the GPIO1 output is enabled (GPIO1_OE = 0x1). 0x0: GPIO1 output driven low. 0x1: GPIO1 output driven by the AFE power-down signal.
	5	0x0	R/W	CLK32M_CAL_EN	As part of the 32 MHz clock calibration routine, write 1 to begin the clock ratio calculation. Read the result of this calculation from the CLK_RATIO bits in Register 0x0A. Reset this bit to 0 prior to reinitiating the calculation.
	[4:0]	0x00	R/W	Reserved	Write 0x0.
0x5F	[15:3]	0x0000	R/W	Reserved	Write 0x0000.
	2	0x0	R/W	SLOTB_DATA_HOLD	Setting this bit prevents the update of the data registers corresponding to Time Slot B. Set this bit to ensure that unread data registers are not updated, guaranteeing a contiguous set of data from all four photodiode channels. 1: hold data registers for Time Slot B. 0: allow data register update.
	1	0x0	R/W	SLOTA_DATA_HOLD	Setting this bit prevents the update of the data registers corresponding to Time Slot A. Set this bit to ensure that unread data registers are not updated, guaranteeing a contiguous set of data from all four photodiode channels. 1: hold data registers for Time Slot A. 0: allow data register update.
	0	0x0	R/W	DIGITAL_CLOCK_ENA	Set to 1 in order to enable the 32 MHz clock when calibrating the 32 MHz clock. Always disable the 32 MHz clock following the calibration by resetting this bit to 0.

ADC REGISTERS

Table 33. ADC Registers

Address	Data Bits	Default Value	Access	Name	Description
0x12	[15:0]	0x0028	R/W	FSAMPLE	Sampling frequency: $f_{\text{SAMPLE}} = 32 \text{ kHz}/(\text{Register } 0x12, \text{ Bits}[15:0] \times 4)$. For example, 100 Hz = 0x0050; 200 Hz = 0x0028.
0x15	[15:11]	0x00	R/W	Reserved	Write 0x0.
	[10:8]	0x6	R/W	SLOTB_NUM_AVG	Sample sum/average for Time Slot B. Specifies the averaging factor, N_B , which is the number of consecutive samples that is summed and averaged after the ADC. Register 0x70 to Register 0x7F hold the data sum. Register 0x64 to Register 0x6B and the data buffer in Register 0x60 hold the data average, which can be used to increase SNR without clipping, in 16-bit registers. The data rate is decimated by the value of the SLOTB_NUMB_AVG bits. 0: 1. 1: 2. 2: 4. 3: 8. 4: 16. 5: 32. 6: 64. 7: 128.
	7	0x0	R/W	Reserved	Write 0x0.
	[6:4]	0x0	R/W	SLOTA_NUM_AVG	Sample sum/average for Time Slot A. N_A : same as Bits[10:8] but for Time Slot A. See description in Register 0x15, Bits[10:8].
	[3:0]	0x0	R/W	Reserved	Write 0x0.
0x18	[15:0]	0x2000	R/W	SLOTA_CH1_OFFSET	Time Slot A Channel 1 ADC offset. The value to subtract from the raw ADC value. A value of 0x2000 is typical.
0x19	[15:0]	0x2000	R/W	SLOTA_CH2_OFFSET	Time Slot A Channel 2 ADC offset. The value to subtract from the raw ADC value. A value of 0x2000 is typical.
0x1A	[15:0]	0x2000	R/W	SLOTA_CH3_OFFSET	Time Slot A Channel 3 ADC offset. The value to subtract from the raw ADC value. A value of 0x2000 is typical.
0x1B	[15:0]	0x2000	R/W	SLOTA_CH4_OFFSET	Time Slot A Channel 4 ADC offset. The value to subtract from the raw ADC value. A value of 0x2000 is typical.
0x1E	[15:0]	0x2000	R/W	SLOTB_CH1_OFFSET	Time Slot B Channel 1 ADC offset. The value to subtract from the raw ADC value. A value of 0x2000 is typical.
0x1F	[15:0]	0x2000	R/W	SLOTB_CH2_OFFSET	Time Slot B Channel 2 ADC offset. The value to subtract from the raw ADC value. A value of 0x2000 is typical.
0x20	[15:0]	0x2000	R/W	SLOTB_CH3_OFFSET	Time Slot B Channel 3 ADC offset. The value to subtract from the raw ADC value. A value of 0x2000 is typical.
0x21	[15:0]	0x2000	R/W	SLOTB_CH4_OFFSET	Time Slot B Channel 4 ADC offset. The value to subtract from the raw ADC value. A value of 0x2000 is typical.

DATA REGISTERS

Table 34. Data Registers

Address	Data Bits	Access	Name	Description
0x60	[15:0]	R	FIFO_DATA	Next available word in FIFO.
0x64	[15:0]	R	SLOTA_CH1_16BIT	16-bit value of Channel 1 in Time Slot A.
0x65	[15:0]	R	SLOTA_CH2_16BIT	16-bit value of Channel 2 in Time Slot A.
0x66	[15:0]	R	SLOTA_CH3_16BIT	16-bit value of Channel 3 in Time Slot A.
0x67	[15:0]	R	SLOTA_CH4_16BIT	16-bit value of Channel 4 in Time Slot A.
0x68	[15:0]	R	SLOTB_CH1_16BIT	16-bit value of Channel 1 in Time Slot B.
0x69	[15:0]	R	SLOTB_CH2_16BIT	16-bit value of Channel 2 in Time Slot B.
0x6A	[15:0]	R	SLOTB_CH3_16BIT	16-bit value of Channel 3 in Time Slot B.
0x6B	[15:0]	R	SLOTB_CH4_16BIT	16-bit value of Channel 4 in Time Slot B.
0x70	[15:0]	R	SLOTA_CH1_LOW	Low data-word for Channel 1 in Time Slot A.
0x71	[15:0]	R	SLOTA_CH2_LOW	Low data-word for Channel 2 in Time Slot A.
0x72	[15:0]	R	SLOTA_CH3_LOW	Low data-word for Channel 3 in Time Slot A.
0x73	[15:0]	R	SLOTA_CH4_LOW	Low data-word for Channel 4 in Time Slot A.
0x74	[15:0]	R	SLOTA_CH1_HIGH	High data-word for Channel 1 in Time Slot A.
0x75	[15:0]	R	SLOTA_CH2_HIGH	High data-word for Channel 2 in Time Slot A.
0x76	[15:0]	R	SLOTA_CH3_HIGH	High data-word for Channel 3 in Time Slot A.
0x77	[15:0]	R	SLOTA_CH4_HIGH	High data-word for Channel 4 in Time Slot A.
0x78	[15:0]	R	SLOTB_CH1_LOW	Low data-word for Channel 1 in Time Slot B.
0x79	[15:0]	R	SLOTB_CH2_LOW	Low data-word for Channel 2 in Time Slot B.
0x7A	[15:0]	R	SLOTB_CH3_LOW	Low data-word for Channel 3 in Time Slot B.
0x7B	[15:0]	R	SLOTB_CH4_LOW	Low data-word for Channel 4 in Time Slot B.
0x7C	[15:0]	R	SLOTB_CH1_HIGH	High data-word for Channel 1 in Time Slot B.
0x7D	[15:0]	R	SLOTB_CH2_HIGH	High data-word for Channel 2 in Time Slot B.
0x7E	[15:0]	R	SLOTB_CH3_HIGH	High data-word for Channel 3 in Time Slot B.
0x7F	[15:0]	R	SLOTB_CH4_HIGH	High data-word for Channel 4 in Time Slot B.

OUTLINE DIMENSIONS

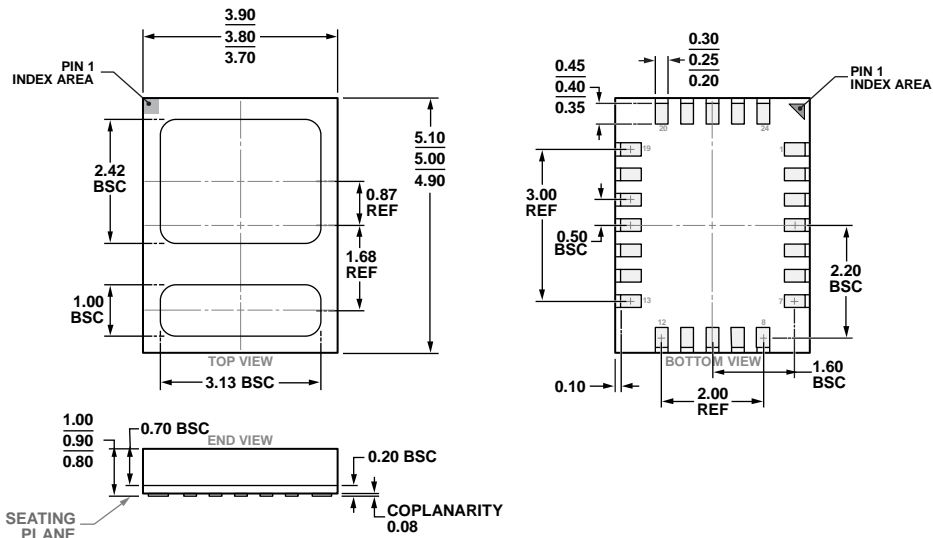

Figure 41. 24-Terminal Chip Array Small Outline No Lead Cavity [LGA_CAV]
 3.80 mm x 5.00 mm Body and 0.9 mm Package Height
 (CE-24-1)
 Dimensions shown in millimeters

ORDERING GUIDE

Model ^{1,2}	Temperature Range	Package Description	Package Option
ADPD188GG-ACEZR7	-40°C to +85°C	24-Terminal Chip Array Small Outline No Lead Cavity [LGA_CAV], 7" Tape and Reel	CE-24-1
ADPD188GG-ACEZRL	-40°C to +85°C	24-Terminal Chip Array Small Outline No Lead Cavity [LGA_CAV], 13" Tape and Reel	CE-24-1
EVAL-ADPD188GGZ		Evaluation Board	

¹ Z = RoHS Compliant Part.

² EVAL-ADPDUCZ is the microcontroller board, ordered separately, required to interface with the EVAL-ADPD188GGZ evaluation board.

Mouser Electronics

Authorized Distributor

Click to View Pricing, Inventory, Delivery & Lifecycle Information:

[Analog Devices Inc.:](#)

[ADPD188GG-ACEZR7](#) [ADPD188GG-ACEZRL](#) [EVAL-ADPD188GGZ](#)