

Ø 7.5 mm Film Dielectric Trimmers



FEATURES

- Housing diameter 7.5 mm
- For a basic grid of 2.54 mm (0.1") or 2.50 mm
- Top and bottom or top adjustment
- Vertical and horizontal versions
- Round head
- Mounting: radial
- Material categorization: for definitions of compliance please see www.vishay.com/doc?99912



RoHS
COMPLIANT

APPLICATIONS

- Antennas
- Impedance matching circuits
- Medical
- RF
- For consumer and industrial equipment

QUICK REFERENCE DATA		
Rated DC voltage		250 V _{DC}
Test DC voltage for 1 min		500 V _{DC}
Maximum contact resistance		10 mΩ
Minimum insulation resistance		10 000 MΩ
Category temperature range	PP	-40 °C to +70 °C
	PE, PTFE, PET	-40 °C to +85 °C
Climatic category (IEC 60068)	PP	40/070/21
	PE, PTFE, PET	40/085/21
Minimum storage temperature		-55 °C
Related specification		IEC 60418-1 and 4
Effective angle of rotation		180° (rotation in 180° only, see "Life of trimmer")
Operating torque	C _{max.} < 33 pF	1 mNm to 15 mNm
	C _{max.} ≥ 33 pF	1 mNm to 25 mNm
Maximum axial thrust		2 N
Capacitance range (C _{min.} / C _{max.})		1.4 pF / 5.5 pF to 3 pF / 33 pF
Life of trimmer		Maximum 10 cycles: rotation in 180° only (the electrical and mechanical performance is not guaranteed if rotated beyond 10 cycles)
Quality level		Sampling and data evaluation for quality level in accordance with "MIL-STD-105D" and "IEC 60410": < 0.15 % major defects < 0.65 % minor defects Each capacitor is tested for minimum C _{max.} and is also subjected to the full test voltage.

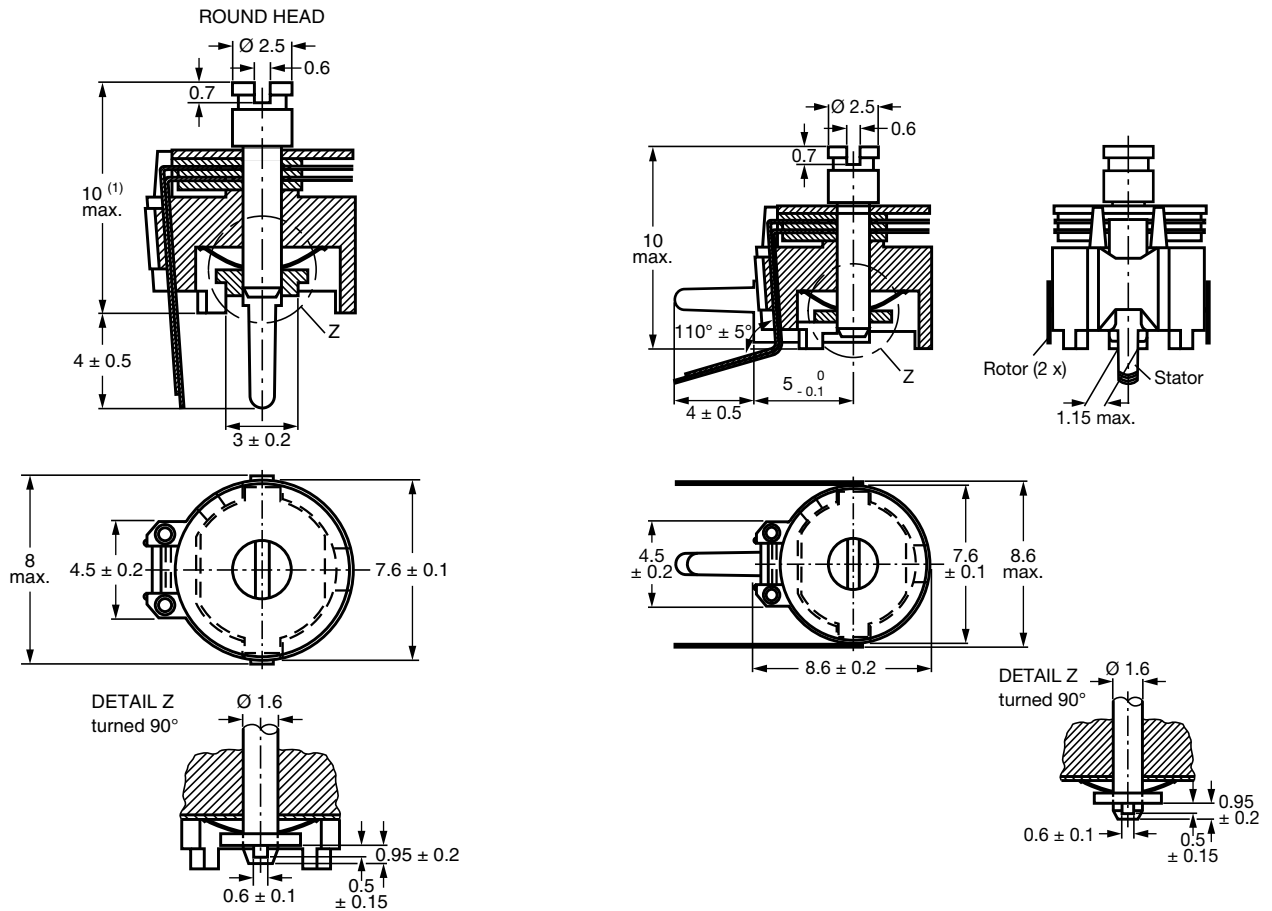
DIMENSIONS in millimeters



Trimmers BFC2 808 series, vertical version

Trimmers BFC2 808 series, horizontal version



R = Rotor, S = Stator

The large hole is for bottom adjustment and the diameter is determined by user's requirements.

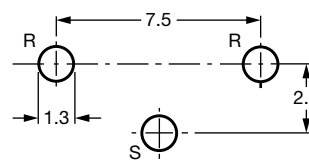

R = Rotor, S = Stator

Hole pattern

ADJUSTMENT

For top adjustment a screwdriver or trimming key can be used; for bottom adjustment a key is required as shown below.



Bottom adjustment key



ORDERING INFORMATION			
C _{min.} / C _{max.} (pF)	CATALOG NUMBER BFC2 808		
	VERTICAL VERSION		HORIZONTAL VERSION
	ROUND HEAD		ROUND HEAD
	TOP AND BOTTOM ADJUSTMENT	TOP ADJUSTMENT ONLY	TOP AND BOTTOM ADJUSTMENT
1.4 / 5.5	11558	00004	51558
2 / 9	00018	-	-
2 / 10	11109	00005	51109
2 / 10	-	11004	-
2 / 15	11159	-	-
2 / 18	00016	-	-
2.5 / 20	-	11006	-
2.5 / 22	11229	00006	51229
3 / 33	11339	-	-

MOUNTING

The trimmer can be mounted on printed-circuit boards with a grid of 2.50 mm or 2.54 mm and a minimum hole diameter of 1.25 mm.

PACKAGING

Bulk packaged in cardboard boxes lined with expanded plastic. For smallest packaging quantity (SPQ) see “Electrical Data” table.

ELECTRICAL DATA											
GUARANTEED MAX. C _{min.} / MIN. C _{max.} AT 200 kHz (pF)	SPINDLE	SHAPE OF HEAD	ADJ. MODE	DIEL.	tan δ AT C _{max.} x 10 ⁻⁴		TEMP. COEFF. (10 ⁻⁶ /K)	MIN. f _{res} AT C _{max.} (MHz)	COL. OF BASE	SPQ	CATALOG NUMBER BFC2
					1 MHz	100 MHz					
1.4 / 5.5	Vertical	Round	Top + bottom	PE	≤ 10	≤ 25	-250 ± 350	850	Grey	1400 808 11558
			Top							1400 808 00004
	Horizontal	Round	Top + bottom							1200 808 51558
2 / 9	Vertical	Round	Top + bottom	PTFE	≤ 10	≤ 15	-150 ± 800	400	Yellow	1400 808 00018
2 / 10	Vertical	Round	Top + bottom	PP	≤ 10	≤ 25	-250 ± 800	480	Yellow	1400 808 11109
			Top							1400 808 00005
	Horizontal	Round	Top + bottom							1200 808 51109
2 / 15	Vertical	Round	Top + bottom	PP	≤ 10	≤ 25	-250 ± 600	450	Blue	1400 808 11159
2 / 18	Vertical	Round	Top + bottom	PTFE	≤ 10	≤ 15	-250 ± 350	350	Green	1400 808 00016
2.5 / 20	Vertical	Round	Top	PET	≤ 160	-	0 ± 1100	250	Green	1000 808 11006
2.5 / 22	Vertical	Round	Top + bottom	PP	≤ 10	≤ 25	-200 ± 500	350	Green	1400 808 11229
			Top							1400 808 00006
	Horizontal	Round	Top + bottom							1200 808 51229
3 / 33	Vertical	Round	Top + bottom	PP	≤ 10	-	-250 ± 350	300	Brown	1400 808 11339



SOLDERING CONDITIONS

For general soldering conditions and wave soldering profile, we refer to the application note “Soldering Guidelines for Film Capacitors”: www.vishay.com/doc?28171

TEST PROCEDURES AND REQUIREMENTS				
IEC 60418-1 CLAUSE	IEC 60068 TEST METHOD	TEST	PROCEDURE	REQUIREMENTS
4.2		Method of mounting	Method A	
14		Capacitance drift	After TC measurement	$\Delta C/C: \leq 1\%$ for $C_{max.} < 40\text{ pF}$; $\Delta C/C: \leq 2.5\%$ for $C_{max.} \geq 40\text{ pF}$
19		Thrust	Axial thrust of 2 N	$\Delta C/C: \leq 0.3\%$
21		Robustness of terminations:		
21.1	Ua	Tensile	1 N	No damage
21.2	Ub	Bending	1 cycle	No damage
22	Na	Rapid change of temperature	1 cycle; 0.5 h at lower and 0.5 h at upper category temperature	$\Delta C/C: \leq 2\%$
23	T	Soldering:		
	Ta	Solderability	Solder bath immersion 3 mm; 235 °C; 2 s	Good wetting, no mechanical damage
	Tb	Resistance to heat	Solder bath: 260 °C; 10 s	No mechanical damage
24	Eb	Impact bump	4000 ± 10 bumps; 40 g; 6 ms	$\Delta C/C: \leq 0.6\%$; no mechanical damage
25	Fc	Vibration	Frequency 10 Hz to 55 Hz; amplitude 0.35 mm; 1.5 h	$\Delta C/C: \leq 0.6\%$; no mechanical damage
26		Climatic sequence:		$\Delta C/C: \leq 4\%$
26.1	B	Dry heat	16 h at upper category temperature	$\tan \delta: \leq 10 \times 10^{-4}$ for $C_{max.} < 27\text{ pF}$; $\tan \delta: \leq 70 \times 10^{-4}$ for $C_{max.} \geq 27\text{ pF}$; $\tan \delta: \leq 80 \times 10^{-4}$ for $C_{max.} \geq 40\text{ pF}$ $R_{ins.} \geq 10\,000\text{ M}\Omega$; rotor contact R: $\leq 10\text{ m}\Omega$
26.2	D	Damp heat accelerated, first cycle	1 cycle; 24 h; +40 °C; 95 % to 100 % RH	Voltage proof: 500 V for 1 min
26.3	Aa	Cold	16 h; -40 °C	Visual examination: no mechanical damage
26.5		Damp heat accelerated, remaining cycles	1 cycle; 24 h; +40 °C; 95 % to 100 % RH	Operating torque: 1 mNm to 15 mNm for $C_{max.} < 33\text{ pF}$; 1 mNm to 25 mNm for $C_{max.} \geq 33\text{ pF}$



TEST PROCEDURES AND REQUIREMENTS				
IEC 60418-1 CLAUSE	IEC 60068 TEST METHOD	TEST	PROCEDURE	REQUIREMENTS
27	Ca	Damp heat steady state	21 days; +40 °C; 90 % to 95 % RH	$\Delta C/C: \leq 5 \%$ $\tan \delta: \leq 30 \times 10^{-4}$ for $C_{max.} < 27 \text{ pF}$; $\tan \delta: \leq 70 \times 10^{-4}$ for $C_{max.} \geq 27 \text{ pF}$; $\tan \delta: \leq 80 \times 10^{-4}$ for $C_{max.} \geq 40 \text{ pF}$ $R_{ins.}: \geq 10\,000 \text{ M}\Omega$; rotor contact R: $\leq 10 \text{ m}\Omega$ Voltage proof: 500 V for 1 min Visual examination: no mechanical damage Operating torque: 1 mNm to 15 mNm for $C_{max.} < 33 \text{ pF}$; 1 mNm to 25 mNm for $C_{max.} \geq 33 \text{ pF}$
29		Mechanical endurance	10 cycles Maximum 10 cycles: rotation in 180° only (the electrical and mechanical performance is not guaranteed if rotated beyond 10 cycles)	$\Delta C/C: \leq 1.5 \%$ $\Delta C/C$ after axial thrust: $\leq 0.3 \%$; rotor contact R: $\leq 10 \text{ m}\Omega$ Voltage proof: 500 V for 1 min Visual examination: no mechanical damage Operating torque: 1 mNm to 15 mNm for $C_{max.} < 33 \text{ pF}$; 1 mNm to 25 mNm for $C_{max.} \geq 33 \text{ pF}$



Disclaimer

ALL PRODUCT, PRODUCT SPECIFICATIONS AND DATA ARE SUBJECT TO CHANGE WITHOUT NOTICE TO IMPROVE RELIABILITY, FUNCTION OR DESIGN OR OTHERWISE.

Vishay Intertechnology, Inc., its affiliates, agents, and employees, and all persons acting on its or their behalf (collectively, "Vishay"), disclaim any and all liability for any errors, inaccuracies or incompleteness contained in any datasheet or in any other disclosure relating to any product.

Vishay makes no warranty, representation or guarantee regarding the suitability of the products for any particular purpose or the continuing production of any product. To the maximum extent permitted by applicable law, Vishay disclaims (i) any and all liability arising out of the application or use of any product, (ii) any and all liability, including without limitation special, consequential or incidental damages, and (iii) any and all implied warranties, including warranties of fitness for particular purpose, non-infringement and merchantability.

Statements regarding the suitability of products for certain types of applications are based on Vishay's knowledge of typical requirements that are often placed on Vishay products in generic applications. Such statements are not binding statements about the suitability of products for a particular application. It is the customer's responsibility to validate that a particular product with the properties described in the product specification is suitable for use in a particular application. Parameters provided in datasheets and/or specifications may vary in different applications and performance may vary over time. All operating parameters, including typical parameters, must be validated for each customer application by the customer's technical experts. Product specifications do not expand or otherwise modify Vishay's terms and conditions of purchase, including but not limited to the warranty expressed therein.

Except as expressly indicated in writing, Vishay products are not designed for use in medical, life-saving, or life-sustaining applications or for any other application in which the failure of the Vishay product could result in personal injury or death. Customers using or selling Vishay products not expressly indicated for use in such applications do so at their own risk. Please contact authorized Vishay personnel to obtain written terms and conditions regarding products designed for such applications.

No license, express or implied, by estoppel or otherwise, to any intellectual property rights is granted by this document or by any conduct of Vishay. Product names and markings noted herein may be trademarks of their respective owners.

Material Category Policy

Vishay Intertechnology, Inc. hereby certifies that all its products that are identified as RoHS-Compliant fulfill the definitions and restrictions defined under Directive 2011/65/EU of The European Parliament and of the Council of June 8, 2011 on the restriction of the use of certain hazardous substances in electrical and electronic equipment (EEE) - recast, unless otherwise specified as non-compliant.

Please note that some Vishay documentation may still make reference to RoHS Directive 2002/95/EC. We confirm that all the products identified as being compliant to Directive 2002/95/EC conform to Directive 2011/65/EU.

Vishay Intertechnology, Inc. hereby certifies that all its products that are identified as Halogen-Free follow Halogen-Free requirements as per JEDEC JS709A standards. Please note that some Vishay documentation may still make reference to the IEC 61249-2-21 definition. We confirm that all the products identified as being compliant to IEC 61249-2-21 conform to JEDEC JS709A standards.