

Both NO and NC contacts incorporated in a DIP8-pin package

PhotoMOS Relays

GU Form A & B (AQW614)

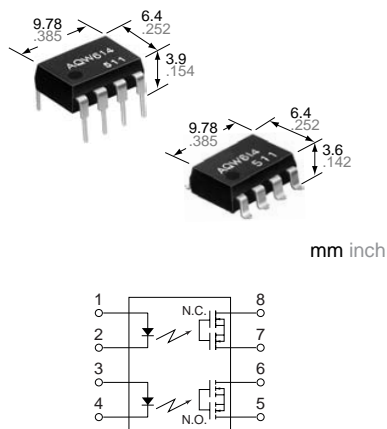

FEATURES

1. Approx. 1/2 the space compared with the mounting of a set of 1 Form A and 1 Form B PhotoMOS relays
2. Applicable for 1 Form A 1 Form B use as well as two independent 1 Form A and 1 Form B use
3. Controls load currents up to 0.13 A with 5 mA input current
4. Extremely low closed-circuit offset voltages to enable control of small analog signals without distortion
5. Stable on-resistance

TYPICAL APPLICATIONS

- High-speed inspection machines
- Telephone equipment
- Computers
- Sensing equipment

Compliance with RoHS Directive

TYPES

	Output rating*		Package	Part No.				Packing quantity	
	Load voltage	Load current		Through hole terminal	Surface-mount terminal			Tube	Tape and reel
					Tape and reel packing style				
			Tube packing style	Picked from the 1/2/3-pin side	Picked from the 4/5/6-pin side				
AC/DC dual use	400 V	100 mA	DIP8-pin	AQW614	AQW614A	AQW614AX	AQW614AZ	1 tube contains: 40 pcs. 1 batch contains: 400 pcs.	1,000 pcs.

*Indicate the peak AC and DC values.
Note: The surface mount terminal shape indicator "A" and the packing style indicator "X" or "Z" are not marked on the relay.

RATING

1. Absolute maximum ratings (Ambient temperature: 25°C 77°F)

	Item	Symbol	AQW614(A)	Remarks
Input	LED forward current	I_F	50 mA	
	LED reverse voltage	V_R	5 V	
	Peak forward current	I_{FP}	1 A	$f = 100$ Hz, Duty factor = 0.1%
	Power dissipation	P_{in}	75 mW	
Output	Load voltage (peak AC)	V_L	400 V	
	Continuous load current	I_L	0.1 A (0.13 A)	Peak AC, DC (): in case of using only 1a or 1b, 1 channel
	Peak load current	I_{peak}	0.3 A	100 ms (1 shot), $V_L = DC$
	Power dissipation	P_{out}	800 mW	
Total power dissipation		P_T	850 mW	
I/O isolation voltage		V_{iso}	1,500 V AC	Between input and output/between contact sets
Temperature limits	Operating	T_{opr}	-40°C to +85°C -40°F to +185°F	Non-condensing at low temperatures
	Storage	T_{stg}	-40°C to +100°C -40°F to +212°F	

GU Form A & B (AQW614)

2. Electrical characteristics (Ambient temperature: 25°C 77°F)

Item		Symbol	AQW614(A)	Condition	
Input	LED operate current	Typical	0.9 mA	$I_L = 100 \text{ mA}$	
		Maximum	3 mA		
	LED reverse current	Minimum	0.4 mA	$I_L = 100 \text{ mA}$	
		Typical	0.8 mA		
LED dropout voltage	Typical	V_F	1.25 V (1.14 V at $I_F = 5 \text{ mA}$)	$I_F = 50 \text{ mA}$	
	Maximum		1.5 V		
Output	On resistance	Typical	27 Ω	$I_F = 5 \text{ mA (N.O.)}$ $I_F = 0 \text{ mA (N.C.)}$ $I_L = 100 \text{ mA}$ within 1 s on time	
		Maximum	50 Ω		
	Off state leakage current	Maximum	I_{Leak}	1 μA	$I_F = 0 \text{ mA (N.O.)}$ $I_F = 5 \text{ mA (N.C.)}$ $V_L = 400 \text{ V}$
Transfer characteristics	Operate time*	Typical	0.28 ms (N.O.) 0.43 ms (N.C.)	$I_F = 0 \text{ mA} \rightarrow 5 \text{ mA}$ $I_L = 100 \text{ mA}$	
		Maximum			1 ms
	Reverse time*	Typical	0.04 ms (N.O.) 0.3 ms (N.C.)	$I_F = 5 \text{ mA} \rightarrow 0 \text{ mA}$ $I_L = 100 \text{ mA}$	
		Maximum			1 ms
	I/O capacitance	Typical	C_{iso}	0.8 pF	$f = 1 \text{ MHz}$ $V_B = 0 \text{ V}$
		Maximum		1.5 pF	
Initial I/O isolation resistance	Minimum	R_{iso}	1,000 M Ω	500 V DC	

*Operate/Reverse time

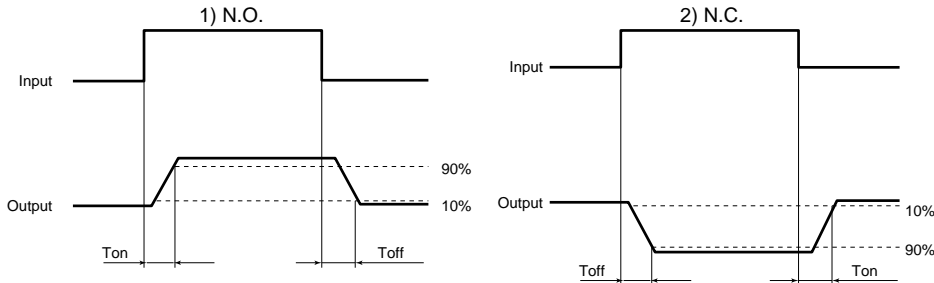

RECOMMENDED OPERATING CONDITIONS

Please obey the following conditions to ensure proper relay operation and resetting.

Item	Symbol	Recommended value	Unit
Input LED current	I_F	5	mA

- For Dimensions
- For Schematic and Wiring Diagrams
- For Cautions for Use

■ These products are not designed for automotive use.

If you are considering to use these products for automotive applications, please contact your local Panasonic Electric Works technical representative.
For more information

REFERENCE DATA

1. Load current vs. ambient temperature characteristics

Allowable ambient temperature: -40°C to +85°C
-40°F to +185°F

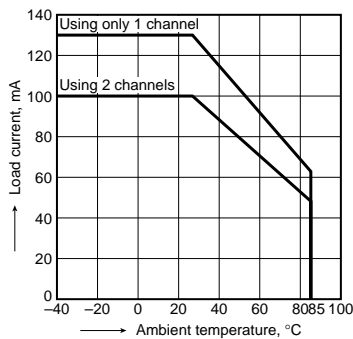

2. On resistance vs. ambient temperature characteristics

Measured portion: between terminals 5 and 6, 7 and 8;
LED current: 5 mA; Load voltage: 400 V (DC);
Continuous load current: 100 mA (DC)

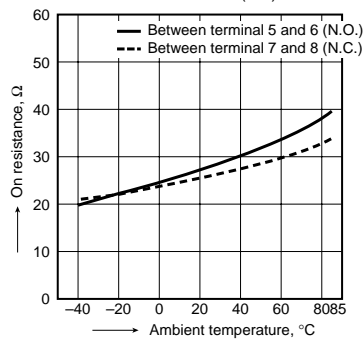

3. Operate time vs. ambient temperature characteristics

LED current: 5 mA;
Load voltage: 400 V (DC);
Continuous load current: 100 mA (DC)

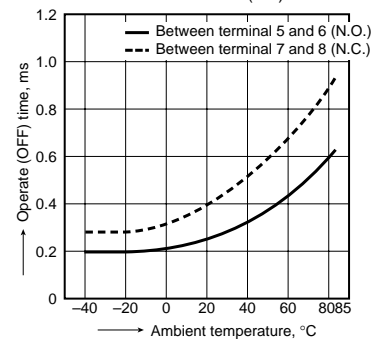

4. Reverse time vs. ambient temperature characteristics

LED current: 5 mA; Load voltage: 400 V (DC);
Continuous load current: 100 mA (DC)

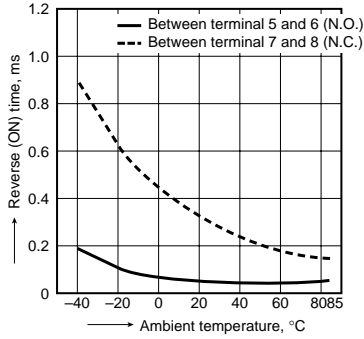

5. LED operate current vs. ambient temperature characteristics

Load voltage: 400 V (DC);
Continuous load current: 100 mA (DC)

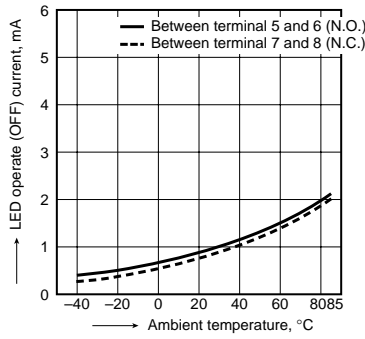

6. LED reverse current vs. ambient temperature characteristics

Load voltage: 400 V (DC);
Continuous load current: 100 mA (DC)

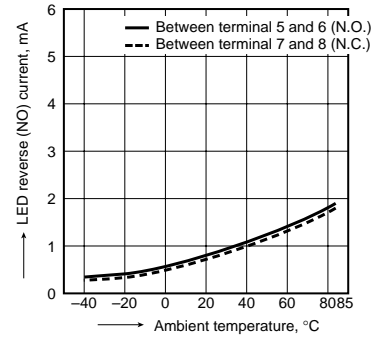

7. LED dropout voltage vs. ambient temperature characteristics

LED current: 5 to 50 mA

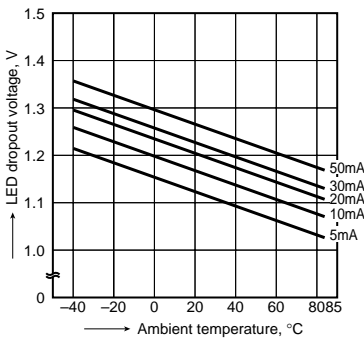

8. Current vs. voltage characteristics of output at MOS portion

Measured portion: between terminals 5 and 6, 7 and 8;
Ambient temperature: 25°C 77°F

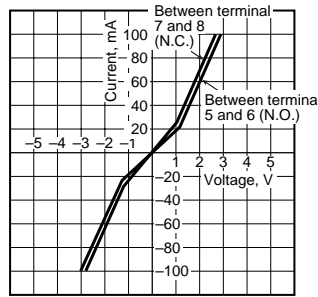

9. Off state leakage current vs. load voltage characteristics

Measured portion: between terminals 5 and 6, 7 and 8;
Ambient temperature: 25°C 77°F

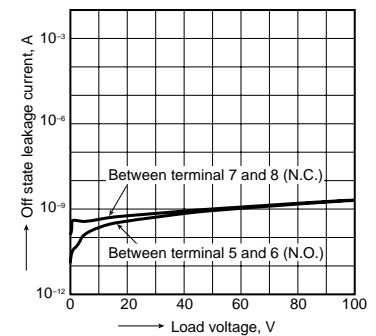

10. Operate time vs. LED forward current characteristics

Measured portion: between terminals 5 and 6, 7 and 8;
Load voltage: 400 V (DC); Continuous load current:
100 mA (DC); Ambient temperature: 25°C 77°F

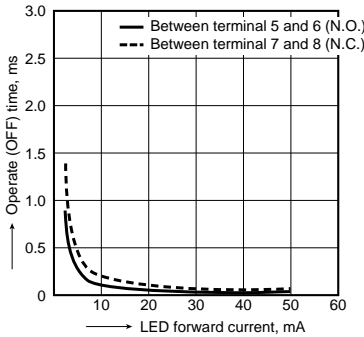

11. Reverse time vs. LED forward current characteristics

Measured portion: between terminals 5 and 6, 7 and 8;
Load voltage: 400 V (DC); Continuous load current:
100 mA (DC); Ambient temperature: 25°C 77°F

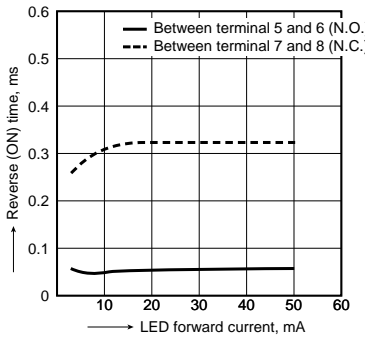

12. Output capacitance vs. applied voltage characteristics

Measured portion: between terminals 5 and 6, 7 and 8;
Frequency: 1 MHz;
Ambient temperature: 25°C 77°F

