

MOUNTING PLATE SIZE

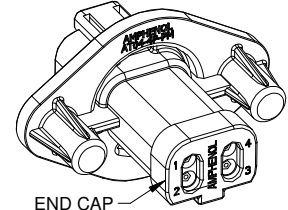
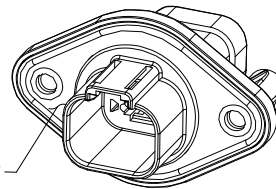
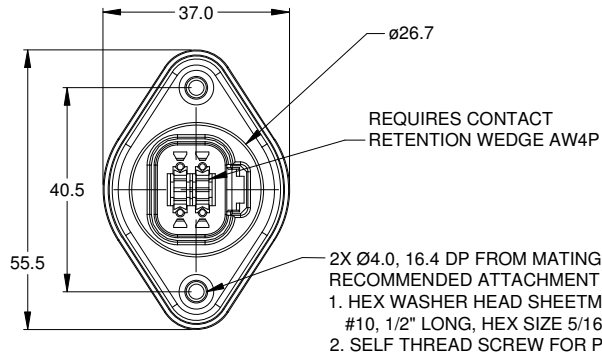
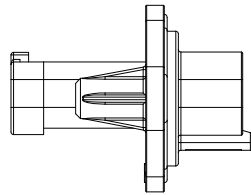
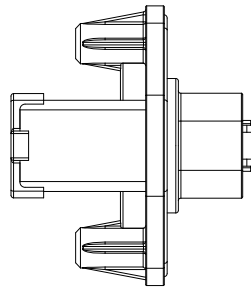
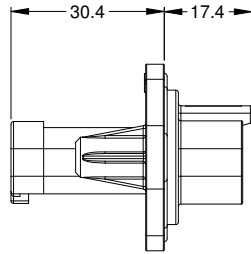

NOTES: UNLESS OTHERWISE SPECIFIED

1. MATERIAL:
HOUSING: THERMOPLASTIC; COLOR: BLACK
SEAL: SILICONE RUBBER
2. MODIFICATIONS: FLANGE, GASKET, REDUCED DIAMETER SEAL, END CAP
3. SPECIFICATIONS:
 - 3.1 CURRENT RATING: 13 AMPS
 - 3.2 OPERATING TEMPERATURE: -55°C TO +125°C
 - 3.3 DIELECTRIC WITHSTANDING VOLTAGE: LESS THAN 2 MILLIAMPS CURRENT LEAKAGE @ 1500 VOLTS AC.
 - 3.4 INSULATION RESISTANCE: 1000 MEGOHMS MIN @ 25°C.
 - 3.5 MOISTURE RESISTANCE: IP67 (MATED CONDITION)
 - 3.6 MATING CYCLE DURABILITY: 100 CYCLES
 - 3.7 RoHS COMPLIANT
4. MATING PART: AT06-4S* PLUG
(* = MODIFICATIONS)
5. ALL DIMENSIONS ARE FOR REFERENCE USE ONLY.

CONTACT SIZE AND REAR SEAL WIRE RANGE:

CONTACT SIZE	MIN. INSUL O.D.	MAX. INSUL O.D.	TYPICAL WIRE RANGE
16	1.35 mm (.053 in)	3.05 mm (.120 in)	14 - 20 AWG

REVISIONS					
REV	ECO	DESCRIPTION	DATE	BY	APPR
A1	-	RELEASE	30APR15	JAH	-

AT04-4P-PM14		PART NUMBER		DESCRIPTION		ITEM
QUANTITY		MATERIALS LIST				
UNLESS OTHERWISE SPECIFIED		SIGNATURES		DATE		<p style="text-align: center;">Amphenol</p> <p style="text-align: center;">Sine Systems - www.amphenol-sine.com 44724 Morley Drive Clinton Township, MI 48036</p> <p style="text-align: center;">RECEPTACLE, 4 PIN, AT SERIES, W/FLANGE, GASKET, RD SEAL, END CAP</p>
1) All dimensions are in metric(mm).		DRAWN: J. HEAD		30APR15		
2) Tolerances are as follows:		CHECKED:				
1 PL DEC ±0.50 Fractions ±1/64		ENGINEER:				
2 PL DEC ±0.15		APPROVAL:				
3 PL DEC ±0.08		CUSTOMER:				
3) Note reference - X		MATERIAL SPECIFICATIONS:		THIS DRAWING IS SUPPLIED FOR INFORMATION ONLY. DESIGN FEATURES, SPECIFICATIONS AND PERFORMANCE DATA SHOWN HEREON ARE THE PROPERTY OF THE AMPHENOL CORPORATION. NO RIGHTS OF REPRODUCTION ARE IMPLIED. ALL DIMENSIONS ARE SUBJECT TO NORMAL MANUFACTURING VARIATIONS.		
PROCESS SPECIFICATIONS:		NEXT ASSY:		SIZE: B C- TYPE: C- DWG NO.: AT04-4P-PM14 REVISION: A1 SCALE: NONE SHEET 1 OF 1		

TITLE: RECEPT., 4 PIN, AT, W/FLANGE, GASKET, RD SEAL, END CAP DWG NO.: AT04-4P-PM14 REV: A1 SH: 1 OF: 1