

SPECIFICATIONS		
PARAMETERS	VALUES	UNITS
RATED VOLTAGE	12	Vdc
OPERATING VOLTAGE RANGE	6 ~ 16	Vdc
RATED CURRENT (MAX)	10	mA
MINIMUM SPL @ 10 CM	88	dBA
RESONANT FREQUENCY	2,900 ± 500	Hz
TONE OR PULSE RATE	FAST PULSE	3 pulse /sec
OPERATING TEMPERATURE	-30 ~ +85	°C
STORAGE TEMPERATURE	-40 ~ +85	°C
HOUSING MATERIAL	NYLON	-
TERMINAL MATERIAL	Sn PLATED BRONZE	-
WEIGHT	13.5	grams

THIS DOCUMENT CONTAINS DATA PROPRIETARY TO PROJECTS UNLIMITED, INC. ANY USE OR REPRODUCTION, IN ANY FORM, WITHOUT PRIOR WRITTEN PERMISSION OF PROJECTS UNLIMITED, INC. IS PROHIBITED.
©2003, Projects Unlimited Inc.

REVISION HISTORY			
LTR	DESCRIPTION	DATE	APPROVED
-	RELEASED FROM ENGINEERING	2/25/2004	
A	REVISED TO INVENTOR 3-D DRAWING TEMPLATE	3/03/2008	B.R.

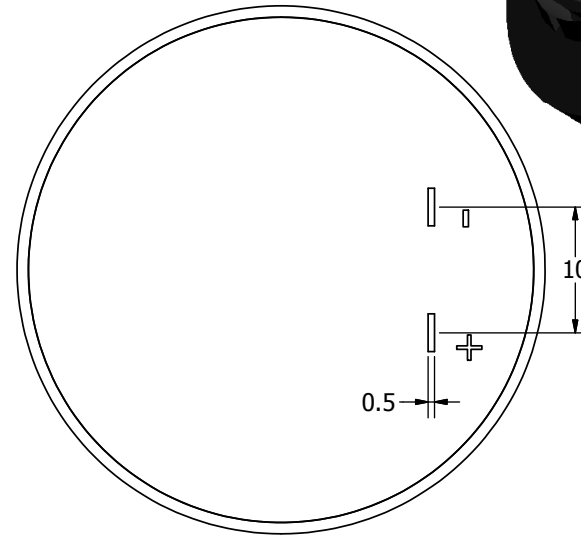
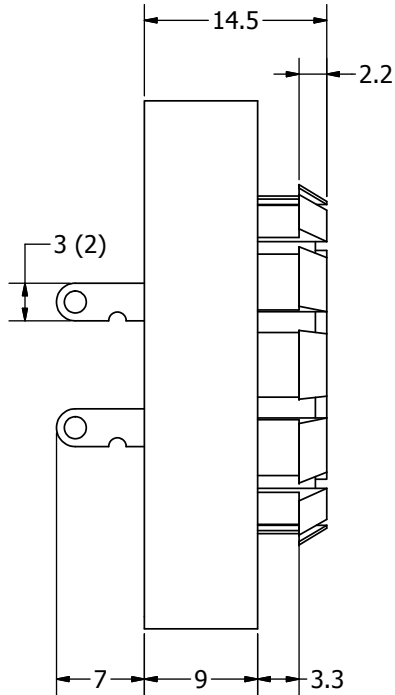
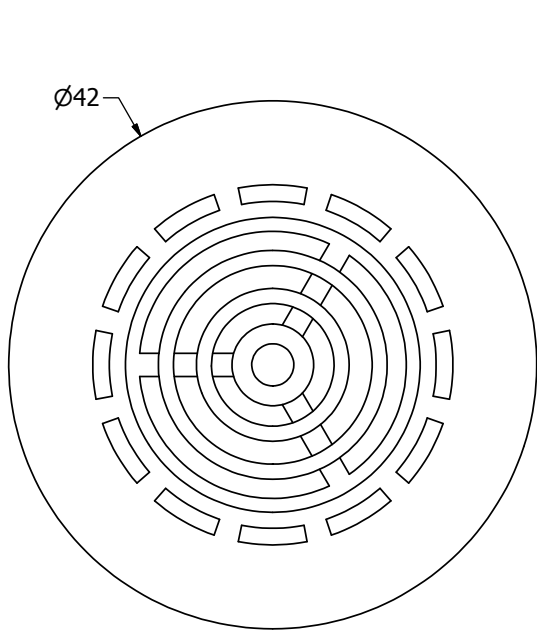
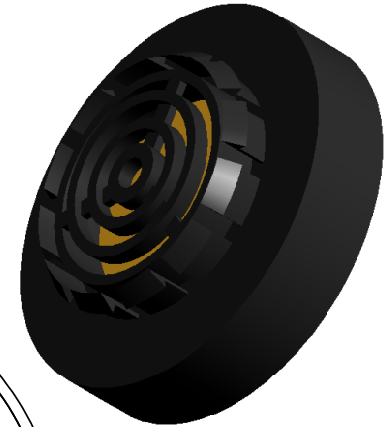

NOTES:

1. ALL DIMENSIONS ARE IN MILLIMETERS.
2. SPECIFICATIONS SUBJECT TO CHANGE OR WITHDRAWAL WITHOUT NOTICE.
3. THIS PART IS RoHS 2002/95/EC COMPLIANT.



UNLESS OTHERWISE SPECIFIED:
DIMENSIONS ARE IN MILLIMETERS,
TOLERANCES ARE ±0.5 AND ANGLES ARE ±3°.

AI-4228-S-FP16-R.idw

SIZE
A3

Designed by	Date	Checked by	Date	Approved by	Date	Drawn Date
J.D.	2/25/2004	E.P.	2/25/2004	B.R.	2/25/2004	3/3/2008



AI-4228-S-FP16-R

UL Indicator

Edition	Sheet
-	1 / 1