

*RoHS Compliant*

# **CompactFlash Series 5**

*Specifications for Industrial CompactFlash Card*

**October 1, 2015**

*Version 1.3*



***Apacer Technology Inc.***

4<sup>th</sup> Fl., 75 Hsin Tai Wu Rd., Sec.1, Hsichih, Taipei Hsien 221, Taiwan

Tel: +886-2-2698-2888 Fax: +886-2-2698-2889

[www.apacer.com](http://www.apacer.com)

## Features:

- **CompactFlash Association Specification Revision 4.1 Standard Interface**
  - 512 bytes per sector
  - ATA command set compatible
  - ATA transfer mode supports:
    - PIO Mode 6
    - Multiword DMA Mode 4
    - Ultra DMA Mode 5
    - PCMCIA UDMA Mode 5
- **Capacities**
  - 4, 8, 16, 32, 64 GB
- **Performance**
  - Sustained read: Up to 50 MB/sec
  - Sustained write: Up to 18 MB/sec
- **Flash Management**
  - Wear-leveling algorithms to substantially increase longevity of flash media
  - Built-in BCH ECC capable of correcting up to 24 bits in 1,024 byte data
  - Supports S.M.A.R.T commands
- **NAND Flash Type: MLC (commercial/Industrial grade)**
- **Power Smart Design**
- **Temperature Ranges**
  - Standard: 0°C to 70°C
  - Extended: -40°C to 85°C
  - Storage: -40°C to 100°C
- **Operating Voltage for Read and Write**
  - 3.3 V
  - 5.0 V
- **Power Consumption (typical)\*\***
  - Active mode: 165 mA
  - Standby mode: 2 mA
- **Connector Type**
  - 50 pins female
- **Physical Dimensions**
  - 36.4mm x 42.8mm x 3.3mm
- **RoHS Compliant**

\*Performance and power consumption may vary depending on capacities and the platforms.

---

## Table of Contents

<b>1. GENERAL DESCRIPTION .....</b>	<b>3</b>
<b>2. FUNCTIONAL BLOCK DIAGRAM .....</b>	<b>3</b>
<b>3. PIN ASSIGNMENTS .....</b>	<b>4</b>
<b>4. PRODUCT SPECIFICATION .....</b>	<b>6</b>
4.1 CAPACITY .....	6
4.2 PERFORMANCE .....	6
4.3 ENVIRONMENTAL SPECIFICATIONS .....	7
<b>5. SOFTWARE INTERFACE .....</b>	<b>7</b>
5.1 CF-ATA COMMAND SET .....	7
<b>6. FLASH MANAGEMENT .....</b>	<b>9</b>
6.1 INTELLIGENT ENDURANCE DESIGN .....	9
6.1.1 <i>Advanced wear-leveling algorithms</i> .....	9
6.1.2 <i>S.M.A.R.T. Technology</i> .....	9
6.1.3 <i>Built-in Hardware ECC</i> .....	9
6.2 INTELLIGENT POWER FAILURE RECOVERY .....	9
<b>7. ELECTRICAL SPECIFICATION .....</b>	<b>10</b>
<b>8. PHYSICAL CHARACTERISTICS .....</b>	<b>11</b>
8.1 DIMENSIONS .....	11
<b>9. PRODUCT ORDERING INFORMATION .....</b>	<b>12</b>
9.1 PRODUCT CODE DESIGNATIONS .....	12
9.2 VALID COMBINATIONS .....	13

## 1. General Description

Apacer's value-added Industrial CompactFlash Card offers high performance, high reliability and power-efficient storage. Regarding standard compliance, this CompactFlash Card complies with CompactFlash specification revision 4.1, supporting transfer modes up to Programmed Input Output (PIO) Mode 6, Multi-word Direct Memory Access (DMA) Mode 4, Ultra DMA Mode 5, and PCMCIA Ultra DMA Mode 5.

For power efficiency, this industrial CompactFlash card supports some power smart design mechanisms such as Power-On-Reset, voltage regulator for output voltage adjustments and power failure protection, as well as the automatic sleep and wake-up feature..

In terms of data integrity and accuracy, the CompactFlash card is built with on-chip hardware 13/24 bit BCH ECC engine that can correct up to 24-bit errors per 1,024 byte data. The 13-bit is used for 2KB page size with 16 bytes spare region per 512 byte data, while the 24-bit ECC is used for flash with 218 or more bytes, accompanied with 4KB data. The controller of this CompactFlash card is designed to transfer the host data through fast DMA engine and utilize the internal memory buffer in a sufficient way, which greatly minimizes the internal microprocessor's loading and improves performance efficiency.

Apacer's value-added CFC provides complete PCMCIA - ATA functionality and compatibility. Apacer's CompactFlash technology is designed for applications in Point of Sale (POS) terminals, telecom, IP-STB, medical instruments, surveillance systems, industrial PCs and handheld applications such as the new generation of Digital Single Lens Reflex (DSLR) cameras.

## 2. Functional Block Diagram

The CompactFlash Card (CFC) includes a controller and flash media, as well as the CompactFlash standard interface. Figure 2-1 shows the functional block diagram.

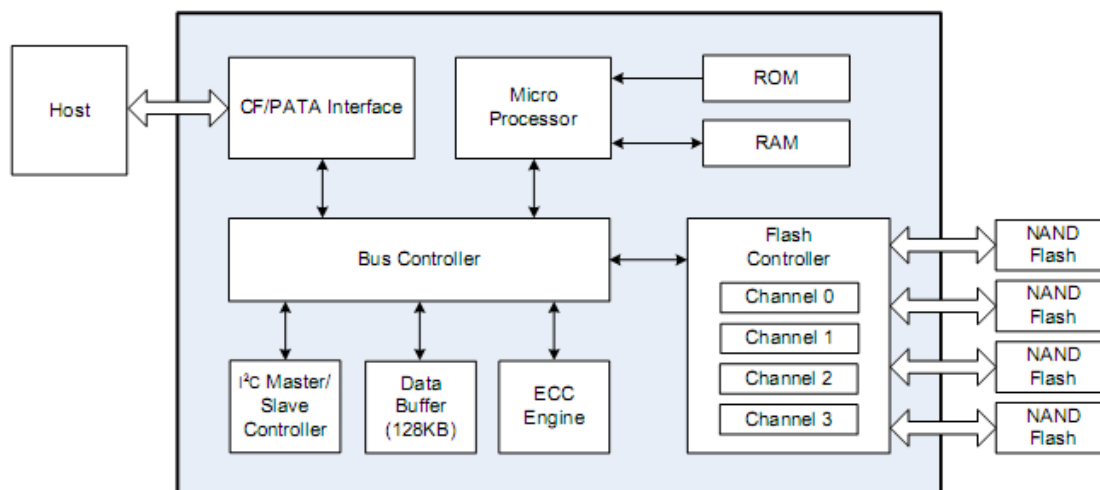

Figure 2-1: Functional block diagram

### 3. Pin Assignments

Table 3-1 lists the pin assignments with respective signal names for the 50-pin configuration. A “#” suffix indicates the active low signal. The pin type can be input, output or input/output.

**Table 3-1:** Pin assignments (1 of 2)

Pin No.	Memory card mode		I/O card mode		True IDE mode	
	Signal name	Pin I/O type	Signal name	Pin I/O type	Signal name	Pin I/O type
1	GND	-	GND	-	GND	-
2	D3	I/O	D3	I/O	D3	I/O
3	D4	I/O	D4	I/O	D4	I/O
4	D5	I/O	D5	I/O	D5	I/O
5	D6	I/O	D6	I/O	D6	I/O
6	D7	I/O	D7	I/O	D7	I/O
7	#CE1	I	#CE1	I	#CS0	I
8	A10	I	A10	I	A10 <sup>1</sup>	I
9	#OE	I	#OE	I	#ATA SEL	I
10	A9	I	A9	I	A9 <sup>1</sup>	I
11	A8	I	A8	I	A8 <sup>1</sup>	I
12	A7	I	A7	I	A7 <sup>1</sup>	I
13	VCC	-	VCC	-	VCC	-
14	A6	I	A6	I	A6 <sup>1</sup>	I
15	A5	I	A5	I	A5 <sup>1</sup>	I
16	A4	I	A4	I	A4 <sup>1</sup>	I
17	A3	I	A3	I	A3 <sup>1</sup>	I
18	A2	I	A2	I	A2	I
19	A1	I	A1	I	A1	I
20	A0	I	A0	I	A0	I
21	D0	I/O	D0	I/O	D0	I/O
22	D1	I/O	D1	I/O	D1	I/O
23	D2	I/O	D2	I/O	D2	I/O
24	WP	O	#IOIS16	O	#IOCS16	O
25	#CD2	O	#CD2	O	#CD2	O
26	#CD1	O	#CD1	O	#CD1	O
27	D11	I/O	D11	I/O	D11	I/O
28	D12	I/O	D12	I/O	D12	I/O
29	D13	I/O	D13	I/O	D13	I/O
30	D14	I/O	D14	I/O	D14	I/O
31	D15	I/O	D15	I/O	D15	I/O
32	#CE2	I	#CE2	I	#CS1	I
33	#VS1	O	#VS1	O	#VS1	O
34	#IORD	I	#IORD	I	#IORD	I
35	#IOWR	I	#IOWR	I	#IOWR	I
36	#WE	I	#WE	I	#WE	I
37	RDY/-BSY	O	#IREQ	O	INTRQ	O
38	VCC	-	VCC	-	VCC	-
39	#CSEL	I	#CSEL	I	#CSEL	I
40	#VS2	O	#VS2	O	#VS2	O
41	RESET	I	RESET	I	#RESET	I

# Compact Flash 5 series

## AP-CFxxxxL9XS-XXXXXX



Table 3-1: Pin assignments (2 of 2)

Pin No.	Memory card mode		I/O card mode		True IDE mode	
	Signal name	Pin I/O type	Signal name	Pin I/O type	Signal name	Pin I/O type
42	#WAIT	O	#WAIT	O	IORDY	O
43	#INPACK	O	#INPACK	O	DMARQ <sup>2</sup>	O
44	#REG	I	#REG	I	DMACK <sup>2</sup>	I
45	BVD2	O	#SPKR	O	#DASP	I/O
46	BVD1	O	#STSCHG	O	#PDIAG	I/O
47	D8	I/O	D8	I/O	D8	I/O
48	D9	I/O	D9	I/O	D9	I/O
49	D10	I/O	D10	I/O	D10	I/O
50	GND	-	GND	-	GND	-

1. The signal should be grounded by the host.
2. Connection required when UDMA is in use.

## 4. Product Specification

### 4.1 Capacity

Capacity specifications of the Compact Flash Card series (CFC) is available as shown in Table 4-1.

**Table 4-1:** Capacity specifications

Capacity	Total bytes <sup>1</sup>	Cylinders	Heads	Sectors	Max LBA
4GB	4,110,188,544	7,964	16	63	8,027,712
8GB	8,195,604,480	15,880	16	63	16,007,040
16GB	16,391,340,032	16,383 <sup>2</sup>	16	63	32,014,336
32GB	32,019,316,736	16,383	16	63	62,537,728
64GB	64,030,244,864	16,383	16	63	125,059,072

<sup>1</sup>Cylinders, heads or sectors are not applicable for these capacities. Only LBA addressing applies

<sup>2</sup>Notes: 1 GB = 1,000,000,000 bytes; 1 sector = 512 bytes.

LBA count addressed in the table above indicates total user storage capacity and will remain the same throughout the lifespan of the device. However, the total usable capacity of the SSD is most likely to be less than the total physical capacity because a small portion of the capacity is reserved for device maintenance usages.

### 4.2 Performance

Performances of the CompactFlash cards are listed in Table 4-2.

**Table 4-2:** Performance specifications

Capacity \ Performance	4 GB (Dual Channel)	4 GB (Single Channel)	8 GB	16 GB	32 GB	64 GB
Sustained read (MB/s)	49	17	50	50	50	50
Sustained write (MB/s)	13	4	14	14	18	18

Notes: performance may vary depending on flash configurations or host system settings.

## 4.3 Environmental Specifications

Environmental specification follows the MIL-STD-810F standards is available as shown in Table 4-3.

**Table 4-3:** Environmental specifications

Environment		Specification
Temperature	Operation	0°C to 70°C / -40°C to 85°C
	Storage	-40°C to 100°C
Vibration (Non-Operation)		Sine wave: 10~2000Hz, 15G (X, Y, Z axes)
Shock (Non-Operation)		Half sine wave, acceleration 1500 G, 0.5 ms (X, Y, Z ; All 6 axes)

## 5. Software Interface

### 5.1 CF-ATA Command Set

Table 5-1 summarizes the CF-ATA command set with the paragraphs that follow describing the individual commands and the task file for each.

**Table 5-1:** CFC-ATA command set

Command	Code	FR <sup>1</sup>	SC <sup>2</sup>	SN <sup>3</sup>	CY <sup>4</sup>	DH <sup>5</sup>	LBA <sup>6</sup>
Check-Power-Mode	E5H or 98H	—	—	—	—	D <sup>8</sup>	—
Execute-Drive-Diagnostic	90H	—	—	—	—	D	—
Erase-Sector(s)	C0H	—	Y <sup>7</sup>	Y	Y	Y <sup>8</sup>	Y
Flush-Cache	E7H	—	—	—	—	D	—
Format-Track	50H	—	Y	—	Y	Y	Y
Identify-Drive	ECH	—	—	—	—	D	—
Idle	E3H or 97H	—	Y	—	—	D	—
Idle-Immediate	E1H or 95H	—	—	—	—	D	—
Initialize-Drive-Parameters	91H	—	Y	—	—	Y	—
NOP	00H	—	—	—	—	D	—
Read-Buffer	E4H	—	—	—	—	D	—
Read-Multiple	C4H	—	Y	Y	Y	Y	Y
Read-Sector(s)	20H or 21H	—	Y	Y	Y	Y	Y
Read-Verify-Sector(s)	40H or 41H	—	Y	Y	Y	Y	Y
Recalibrate	1XH	—	—	—	—	D	—
Request-Sense	03H	—	—	—	—	D	—
Seek	7XH	—	—	Y	Y	Y	Y
Set-Features	EFH	Y	—	—	—	D	—
Set-Multiple-mode	C6H	-	Y	-	-	D	-

# Compact Flash 5 series

## AP-CFxxxxL9XS-XXXXXX



Set-Sleep-Mode	E6H or 99H	–	–	–	–	D	–
Standby	E2H or 96H	–	–	–	–	D	–
Standby-Immediate	E0H or 94H	–	–	–	–	D	–
Translate-Sector	87H	–	Y	Y	Y	Y	Y
Write-Buffer	E8H	–	–	–	–	D	–
Write-Multiple	C5H	–	Y <sup>7</sup>	Y	Y	Y	Y
Write-Multiple-Without-Erase	CDH	–	Y	Y	Y	Y	Y
Write-Sector(s)	30H or 31H	–	Y	Y	Y	Y	Y
Write-Sector(s)-Without-Erase	38H	–	Y	Y	Y	Y	Y
Write-Verify	3CH	–	Y	Y	Y	Y	Y

1. FR - Features register
2. SC - Sector Count register
3. SN - Sector Number register
4. CY - Cylinder registers
5. DH - Drive/Head register
6. LBA - Logical Block Address mode supported
7. Y - The register contains a valid parameter for this command
8. For the Drive/Head register:  
 Y means both the CompactFlash card and head parameters are used;  
 D means only the CompactFlash card parameter is valid and not the head parameter

---

## **6. Flash Management**

### **6.1 Intelligent Endurance Design**

---

#### **6.1.1 Advanced wear-leveling algorithms**

Flash memory devices differ from Hard Disk Drives (HDDs) in terms of how blocks are utilized. For HDDs, when a change is made to stored data, like erase or update, the controller mechanism on HDDs will perform overwrites on blocks. On the other hand, NAND flash storage adopts flash as their primary media. Unlike HDDs, flash blocks cannot be overwritten and each P/E cycle wears down the lifespan of blocks gradually. Repeatedly program/erase cycles performed on the same memory cells will eventually cause some blocks to age faster than others. This would bring flash storages to their end of service term earlier. Wear leveling is an important mechanism that level out the wearing of blocks so that the wearing-down of blocks can be almost evenly distributed. This will increase the lifespan of SSDs. Commonly used wear leveling types are Static and Dynamic.

#### **6.1.2 S.M.A.R.T. Technology**

S.M.A.R.T. is an acronym for Self-Monitoring, Analysis and Reporting Technology, an open standard allowing disk drives to automatically monitor their own health and report potential problems. It protects the user from unscheduled downtime by monitoring and storing critical drive performance and calibration parameters. Ideally, this should allow taking proactive actions to prevent impending drive failure. Apacer SMART feature adopts the standard SMART command B0h to read data from the drive. When the Apacer SMART Utility running on the host, it analyzes and reports the disk status to the host before the device is in critical condition.

#### **6.1.3 Built-in Hardware ECC**

The ECC bit encoding takes places when host/OS writes data to the SSD. This step is simpler and quick. On the other hand, the ECC bit decoding is processed when host/OS reads data from the SSD. In this step, the ECC codes will be in progress for detecting, comparing and detecting potential error. Thus, the power of the ECC lies mostly in the read data side.

This ATA CompactFlash card employs BCH Error Correction Code (ECC) algorithms. This on-chip hardware BCH-ECC engines is 13/24 bit programmed that can correct up to 24-bit errors per 1,024 byte data. This built-in hardware ECC performs parity generation and error detection/correction for data integrity.

### **6.2 Intelligent Power Failure Recovery**

---

Power Failure Management ensures data transmission when experiencing unstable power supply. When power disruption takes places, NAND Flash will have to cache multiple write-to-flash cycles to securely store data. This urgent operation requires about several milliseconds to get it done. When the supplied voltage is below a certain percentage of the required, the flash controller will be signaled by a detector IC component with low power detection signal and then the firmware will communicate the controller to flush all the data into the cache of Flash storage area. This can prevent incomplete data transmission. The crucial part lies in the strength of the capacitor of the SSD. The capacitor must be able to hold up some milliseconds of remaining time before the power is totally out, for the urgent write-back-into-flash operations to complete.

## 7. Electrical Specification

**Table 7-1:** Operating range

Range	Ambient Temperature	3.3V	5V
Standard Temperature	0°C to 70°C	3.135-3.465V	4.75-5.25V
Extended Temperature	-40°C to +85°C		
Storage Temperature	-40°C to +100°C		

**Table 7-2:** Power consumption (at 5V, typical)

Modes \ Capacity	4 GB	4 GB	8 GB	16 GB	32 GB	64 GB
	(Dual Channel)	(Single Channel)				
<b>Active (mA)</b>	150	150	155	165	165	170
<b>Idle (mA)</b>	5	5	5	5	5	5

Notes: results may vary depending on flash configurations or platforms.



## 9. Product Ordering Information

### 9.1 Product Code Designations

**A P - C F x x x x L 9 X S - X X X X X X**

**Specification**

- RM: Removable
- NR: Non-Removable
- NDRM: Non-DMA + Removable
- NDNR: Non-DMA + Non-Removable
- ETRM: Ext. Temp. + Removable
- ETNR: Ext. Temp. + Non-Removable
- ETNDRM: Ext. Temp + Non-DMA + Removable
- ETNDNR: Ext. Temp + Non-DMA + Non-Removable

**Halogen Free Compliant**

**Configuration**  
 E : Single Channel  
 F : Dual Channel

**CTL Type**

**CFC Type**

**Capacities:**  
 004G = 4GB  
 008G = 8GB  
 016G = 16GB  
 032G = 32GB  
 064G = 64GB

**Model Name**

**Apacer Product Code**

---

## 9.2 Valid Combinations

---

### 9.2.1 Standard Temperature

#### 9.2.1.1 Non-Removable

<b>Capacity</b>	<b>AP/N</b>
4GB	AP-CF004GL9FS-NR
4GB	AP-CF004GL9ES-NR
8GB	AP-CF008GL9FS-NR
16GB	AP-CF016GL9FS-NR
32GB	AP-CF032GL9FS-NR
64GB	AP-CF064GL9FS-NR

#### 9.2.1.2 Removable

<b>Capacity</b>	<b>AP/N</b>
4GB	AP-CF004GL9FS-RM
4GB	AP-CF004GL9ES-RM
8GB	AP-CF008GL9FS-RM
16GB	AP-CF016GL9FS-RM
32GB	AP-CF032GL9FS-RM
64GB	AP-CF064GL9FS-RM

#### 9.2.1.3 Non-DMA + Removable

<b>Capacity</b>	<b>AP/N</b>
4GB	AP-CF004GL9FS-NDRM
4GB	AP-CF004GL9ES-NDRM
8GB	AP-CF008GL9FS-NDRM
16GB	AP-CF016GL9FS-NDRM
32GB	AP-CF032GL9FS-NDRM
64GB	AP-CF064GL9FS-NDRM

---

**9.2.1.4 Non-DMA + Non-Removable**

<b>Capacity</b>	<b>AP/N</b>
4GB	AP-CF004GL9FS-NDNR
4GB	AP-CF004GL9ES-NDNR
8GB	AP-CF008GL9FS-NDNR
16GB	AP-CF016GL9FS-NDNR
32GB	AP-CF032GL9FS-NDNR
64GB	AP-CF064GL9FS-NDNR

**Note:** please consult with Apacer sales representative for availability.

**9.2.2 Extended Temperature**

**9.2.2.1 Ext. Temp. + Non-Removable**

<b>Capacity</b>	<b>AP/N</b>
4GB	AP-CF004GL9ES-ETNR
8GB	AP-CF008GL9FS-ETNR
16GB	AP-CF016GL9FS-ETNR
32GB	AP-CF032GL9FS-ETNR

**9.2.2.2 Ext. Temp. + Removable**

<b>Capacity</b>	<b>AP/N</b>
4GB	AP-CF004GL9ES-ETRM
8GB	AP-CF008GL9FS-ETRM
16GB	AP-CF016GL9FS-ETRM
32GB	AP-CF032GL9FS-ETRM

# Compact Flash 5 series

## AP-CFxxxxL9XS-XXXXXX



---

### 9.2.2.3 Non-DMA + Removable

<b>Capacity</b>	<b>AP/N</b>
4GB	AP-CF004GL9ES-ETNDRM
8GB	AP-CF008GL9FS-ETNDRM
16GB	AP-CF016GL9FS-ETNDRM
32GB	AP-CF032GL9FS-ETNDRM

### 9.2.2.4 Non-DMA + Non-Removable

<b>Capacity</b>	<b>AP/N</b>
4GB	AP-CF004GL9ES-ETNDNR
8GB	AP-CF008GL9FS-ETNDNR
16GB	AP-CF016GL9FS-ETNDNR
32GB	AP-CF032GL9FS-ETNDNR

**Note:** please consult with Apacer sales representative for availability.

---

## Revision History

Revision	Date	Description	Remark
0.1	03/13/2012	Preliminary	
1.0	04/12/2012	Official release	
1.1	07/23/2012	Updated Product Ordering Information (with the addition of standard operating temperature models) Added 64GB capacity	
1.2	09/20/2012	Added standard operating temperature specifications Updated Product Ordering Information due to the addition of standard temperature specifications Added 4GB capacity model	
1.3	10/01/2015	Added 4GB models of single channel.	

---

## Global Presence

<b>Taiwan (Headquarters)</b>	<b>Apacer Technology Inc.</b> 4 <sup>th</sup> Fl., 75 Hsin Tai Wu Rd., Sec.1 Hsichih, 221 Taipei Hsien Taiwan, R.O.C. Tel: +886-2-2698-2888 Fax: +886-2-2698-2889 <a href="mailto:amtsales@apacer.com">amtsales@apacer.com</a>
<b>U.S.A.</b>	<b>Apacer Memory America, Inc.</b> 46732 Lakeview Blvd., Fremont, CA 94538 Tel: 1-408-518-8699 Fax: 1-510-249-9568 <a href="mailto:sa@apacerus.com">sa@apacerus.com</a>
<b>Japan</b>	<b>Apacer Technology Corp.</b> 5F, Matsura Bldg., Shiba, Minato-Ku Tokyo, 105-0014, Japan Tel: 81-3-5419-2668 Fax: 81-3-5419-0018 <a href="mailto:jpservices@apacer.com">jpservices@apacer.com</a>
<b>Europe</b>	<b>Apacer Technology B.V.</b> Science Park Eindhoven 5051 5692 EB Son, The Netherlands Tel: 31-40-267-0000 Fax: 31-40-267-0000#6199 <a href="mailto:sales@apacer.nl">sales@apacer.nl</a>
<b>China</b>	<b>Apacer Electronic (Shanghai) Co., Ltd</b> Room D, 22/FL, No.2, Lane 600, JieyunPlaza, Tianshan RD, Shanghai, 200051, China Tel: 86-21-6228-9939 Fax: 86-21-6228-9936 <a href="mailto:sales@apacer.com.cn">sales@apacer.com.cn</a>
<b>India</b>	<b>Apacer Technologies Pvt Ltd,</b> Unit No.201, "Brigade Corner", 7 <sup>th</sup> Block Jayanagar, Yediyur Circle, Bangalore – 560082, India Tel: 91-80-4152-9061 Fax: 91-80-4170-0215 <a href="mailto:sales_india@apacer.com">sales_india@apacer.com</a>

# Mouser Electronics

Authorized Distributor

Click to View Pricing, Inventory, Delivery & Lifecycle Information:

[Apacer:](#)

[AP-CF004GL9FS-NR](#) [AP-CF008GL9FS-NR](#) [AP-CF016GL9FS-NR](#) [AP-CF032GL9FS-NR](#) [AP-CF064GL9FS-NR](#) [AP-CF032GL9FS-ETNR](#) [AP-CF008GL9FS-ETNR](#) [AP-CF016GL9FS-ETNR](#) [AP-CF004GL9ES-ETNR](#) [AP-CF004GL9ES-NR](#)