



Anaren Integrated Radio 2500 Series



A2500R24A

The A2500R24A is a high-performance, FCC-certified radio module that incorporates the Texas Instruments CC2500 transceiver chip in the industry's smallest package (9 x 12 x 2.5mm).

Features

- Frequency range: 2400-2483.5 MHz
- FCC compliant, shielded package
- Digital RSSI output
- Programmable output power up to +0.5dBm
- High sensitivity (-104 dBm at 2.4 kBaud, 2442 MHz 1% packet error rate)
- Ultra-small package size 9 x 12 x 2.5mm
- LGA footprint
- RoHS compliant
- Operating temperature -40 to +85C
- Impedance-controlled, multi-layer PCB
- 1.8 to 3.6 VDC
- Low current consumption (16 mA in RX, 250 kBaud, 2442 MHz)
- 400 nA sleep mode current consumption
- Efficient SPI interface; all registers can be programmed with one "burst" transfer
- Available in tape & reel and matrix tray

Benefits

- No RF engineering experience necessary
- No additional FCC "Part 15" certification required
- Minimal real estate required
- Easily implemented on a two layer PCB
- No additional harmonic filtering required
- 100% RF-tested in production
- Common footprint for product family
- No additional DC decoupling required
- Integrated analog temperature sensor
- Excellent receiver selectivity and blocking performance
- Suitable for frequency hopping systems, thanks to a fast-settling frequency synthesizer with 90 μ s settling time
- Impedance-matched balun for optimized efficiency
- Support for asynchronous and synchronous serial receive/transmit mode for backwards compatibility with existing radio communication protocols

Block diagram

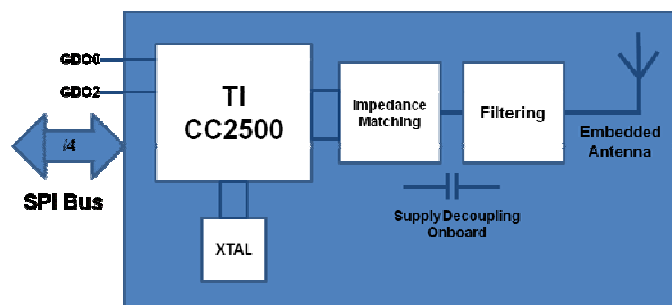

PLEASE NOTE: Additional information on the Texas Instruments CC2500 device can be found in the company's latest datasheet release at <http://www.ti.com>



This product shall not be used in any of the following products or systems without prior express written permission from Anaren Microwave, Inc:

- implantable cardiac rhythm management systems, including without limitation pacemakers, defibrillators and cardiac resynchronization devices;
- external cardiac rhythm management systems that communicate directly with one or more implantable medical devices; or
- other devices used to monitor or treat cardiac function, including without limitation pressure sensors, biochemical sensors and neurostimulators.



Anaren, Inc. / 6635 Kirkville Road / East Syracuse, NY 13057
800.411.6596 / <http://www.anaren.com> / air@anaren.com



Anaren Integrated Radio

Product overview

The A2500R24A is a high-performance, FCC-certified radio module that incorporates the Texas Instruments CC2500 transceiver chip in the industry's smallest package (9 x 12 x 2.5mm) and is compatible with all TI-approved software stacks.

With an LGA pad footprint, this module is designed to effortlessly integrate into a wide range of applications, including: industrial control, building automation, low-power wireless sensor networks, lighting control, and automated meter reading.

The A2500R24A has an RoHS-compliant ENIG finish and is packaged on tape and reel for high-volume automated manufacturing.

Footprint

Top 2 pads optional for compatibility with other modules. Refer to User's Manual for additional layout guidelines. Dimensions in mm.

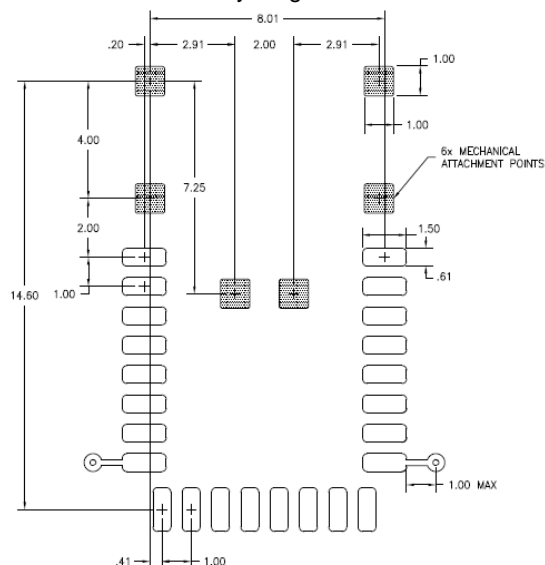

Pin diagram

DNC = Do Not Connect

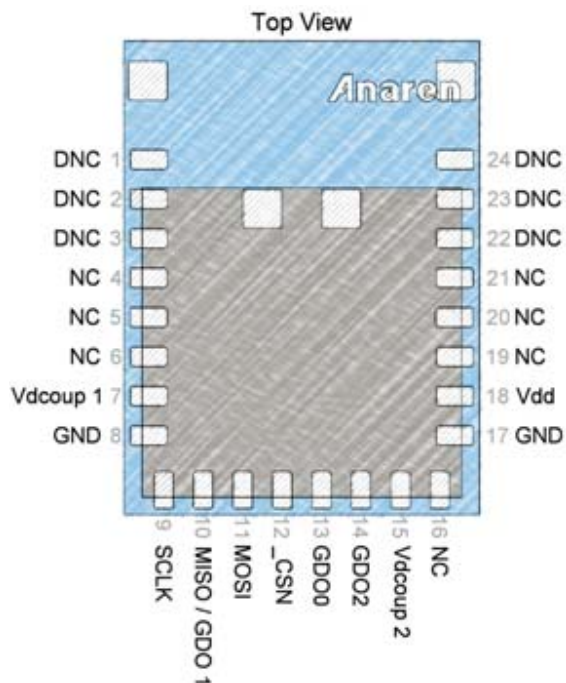

Nomenclature

A2500R24A00GR

1 2 3 4 5 6 7

- | | |
|---|---|
| A | (Anaren) |
| 1 | Chip series (1101, 2500) |
| 2 | Function (R = radio only) |
| 3 | Frequency band (x100MHz) |
| 4 | Form factor (A = Internal Antenna, C = Connector) |
| 5 | Design ID (00 = Default) |
| 6 | Application (G = General) |
| 7 | Packaging (R = Tape/Reel, M = Matrix Tray) |



Caution! ESD sensitive device. Precautions should be used when handling the device in order to prevent permanent damage.



Anaren, Inc. / 6635 Kirkville Road / East Syracuse, NY 13057
800.411.6596 / <http://www.anaren.com> / air@anaren.com