

## Description

Atmel® ATWINC1500B is a single chip IEEE® 802.11 b/g/n Radio/Baseband/MAC network controller optimized for low-power mobile applications. ATWINC1500B supports single stream 1x1 802.11n mode providing up to 72Mbps PHY rate. ATWINC1500B features fully integrated Power Amplifier, LNA, Switch, and Power Management. ATWINC1500B also features an on-chip microcontroller and integrated Flash memory for system software. Implemented in 65nm CMOS technology, the ATWINC1500B offers very low power consumption while simultaneously providing high performance and minimal bill of materials.

The ATWINC1500B supports 2- and 3-wire Bluetooth® coexistence protocols. The ATWINC1500B provides multiple peripheral interfaces including UART, SPI, I<sup>2</sup>C the only external clock source needed for the ATWINC1500B is a high-speed crystal or oscillator with a wide range of reference clock frequencies supported (12-40MHz). The ATWINC1500B is available in QFN packaging.

## Features

- IEEE 802.11 b/g/n 20MHz (1x1) solution
- Single spatial stream in 2.4GHz ISM band
- Integrated PA and T/R Switch
- Superior Sensitivity and Range via advanced PHY signal processing
- Advanced Equalization and Channel Estimation
- Advanced Carrier and Timing Synchronization
- Wi-Fi Direct and Soft-AP support
- Supports IEEE 802.11 WEP, WPA, and WPA2 Security
- Supports China WAPI security
- Superior MAC throughput via hardware accelerated two-level A-MSDU/A-MPDU frame aggregation and block acknowledgement
- On-chip memory management engine to reduce host load
- Integrated Flash memory for system software
- SPI, UART, and I<sup>2</sup>C host interfaces
- 2- or 3-wire Bluetooth coexistence interface
- Operating temperature range of -40°C to +85°C
- Power save modes:
  - <4µA Power Down mode typical @3.3V I/O

- 380uA Doze mode with chip settings preserved (used for beacon monitoring)
  - On-chip low power sleep oscillator
  - Fast host wake-up from Doze mode by a pin or host I/O transaction
- Fast boot options:
  - On-Chip Boot ROM (firmware instant boot)
  - SPI Flash boot (firmware patches and state variables)
  - Low-leakage on-chip memory for state variables
  - Fast AP re-association (150ms)
- On-Chip Network Stack to offload MCU:
  - Integrated Network IP stack to minimize host CPU requirements
  - Network features: TCP, UDP, DHCP, ARP, HTTP, SSL, and DNS
- Hardware accelerators for Wi-Fi and SSL security to improve connection time
- Hardware accelerator for IP checksum
- Hardware accelerators for OTA security

## Table of Contents

---

<b>Description</b> .....	<b>1</b>
<b>Features</b> .....	<b>1</b>
<b>Table of Contents</b> .....	<b>3</b>
<b>1 Ordering Information and IC Marking</b> .....	<b>5</b>
<b>2 Block Diagram</b> .....	<b>5</b>
<b>3 Pinout and Package Information</b> .....	<b>5</b>
3.1 Pin Description .....	5
3.2 Package Description .....	7
<b>4 Electrical Specifications</b> .....	<b>9</b>
4.1 Absolute Ratings .....	9
4.2 Recommended Operating Conditions .....	9
4.3 DC Electrical Characteristics .....	10
<b>5 Clocking</b> .....	<b>10</b>
5.1 Crystal Oscillator .....	10
5.2 Low Power Oscillator .....	11
<b>6 CPU and Memory Subsystems</b> .....	<b>12</b>
6.1 Processor .....	12
6.2 Memory Subsystem .....	12
6.3 Non-Volatile Memory (eFuse) .....	12
<b>7 WLAN Subsystem</b> .....	<b>13</b>
7.1 MAC .....	13
7.1.1 Features .....	13
7.1.2 Description .....	13
7.2 PHY .....	14
7.2.1 Features .....	14
7.2.2 Description .....	14
7.3 Radio .....	14
7.3.1 Receiver Performance .....	14
7.3.2 Transmitter Performance .....	16
<b>8 External Interfaces</b> .....	<b>17</b>
8.1 I <sup>2</sup> C Slave Interface .....	17
8.2 I <sup>2</sup> C Master Interface .....	19
8.3 SPI Slave Interface .....	19
8.4 UART .....	22
8.5 Wi-Fi/Bluetooth Coexistence .....	22
8.6 GPIOs .....	23
<b>9 Power Management</b> .....	<b>24</b>
9.1 Power Architecture .....	24
9.2 Power Consumption .....	25
9.2.1 Description of Device States .....	25

9.2.2	Current Consumption in Various Device States.....	25
9.2.3	Restrictions for Power States .....	26
9.3	Power-Up/Down Sequence .....	26
9.4	Digital I/O Pin Behavior during Power-Up Sequences.....	28
<b>10</b>	<b>Reference Design .....</b>	<b>29</b>
<b>11</b>	<b>Reference Documentation and Support.....</b>	<b>30</b>
11.1	Reference Documents.....	30
<b>12</b>	<b>Revision History .....</b>	<b>31</b>

# 1 Ordering Information and IC Marking

Table 1-1. Ordering Details

Atmel Official Part Number (for ordering)	Package Type	IC Marking
ATWINC1500B-MU	5x5 QFN in Tape and Reel	ATWINC1500B

# 2 Block Diagram

Figure 2-1. ATWINC1500B Block Diagram

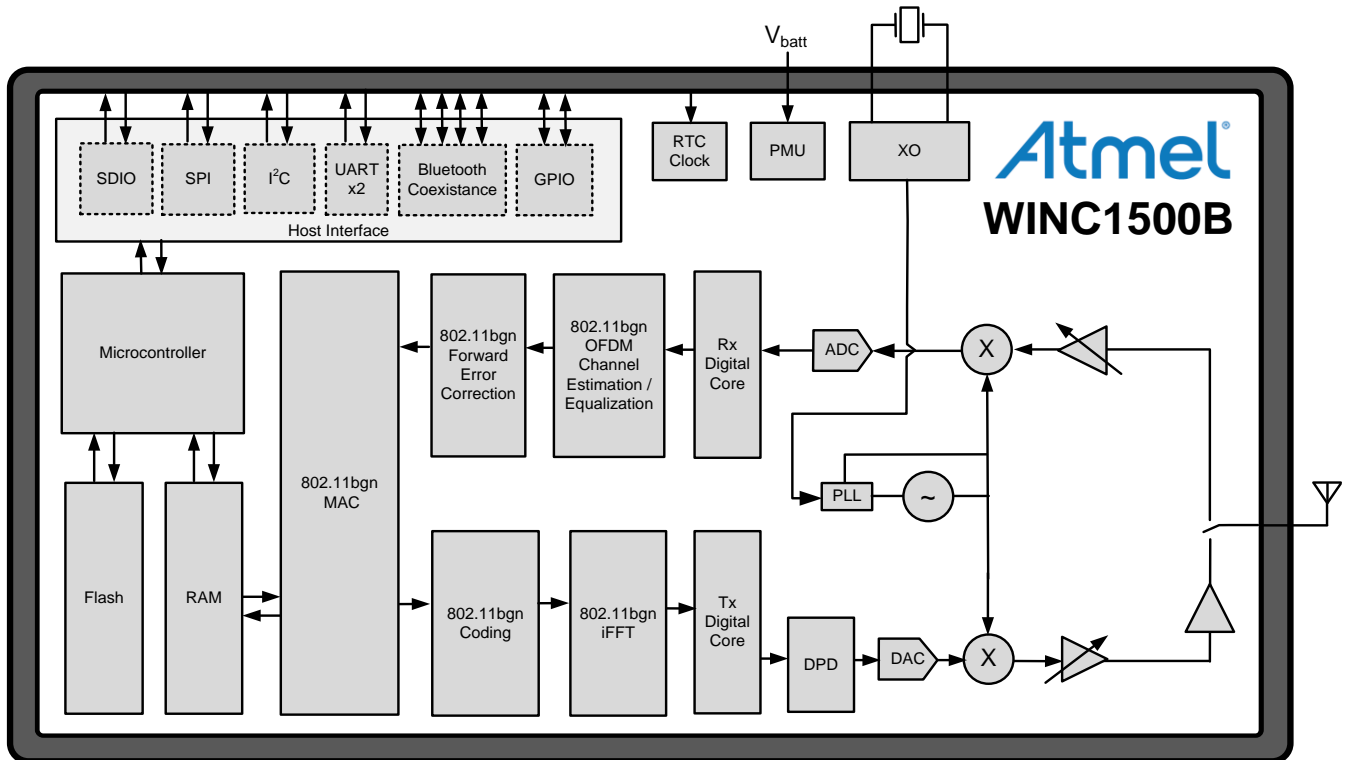

# 3 Pinout and Package Information

## 3.1 Pin Description

ATWINC1500B is offered in an exposed pad 40-pin QFN package. This package has an exposed paddle that must be connected to the system board ground. The QFN package pin assignment is shown in Figure 3-1. The color shading is used to indicate the pin type as follows:

- Green – power
- Red – analog
- Blue – digital I/O
- Yellow – digital input
- Grey – unconnected or reserved

The ATWINC1500B pins are described in Table 3-1.

**Figure 3-1. Pin Assignment**

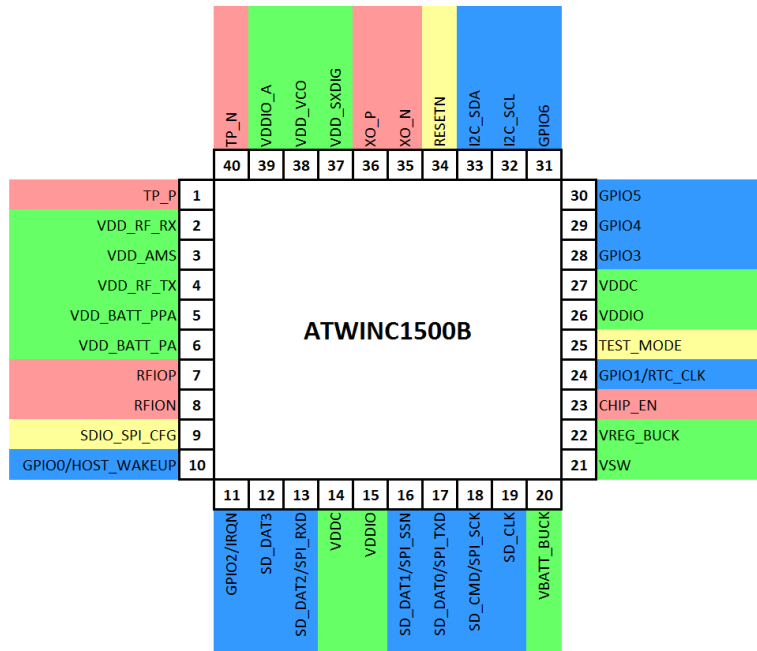

**Table 3-1. Pin Description**

Pin #	Pin Name	Pin Type	Description
1	TP_P	Analog	Test Pin/Customer No Connect
2	VDD_RF_RX	Power	Tuner RF Supply (see Section 9.1)
3	VDD_AMS	Power	Tuner BB Supply (see Section 9.1)
4	VDD_RF_TX	Power	Tuner RF Supply (see Section 9.1)
5	VDD_BATT_PPA	Power	PA 1st Stage Supply (see Section 9.1)
6	VDD_BATT_PA	Power	PA 2nd Stage Supply (see Section 9.1)
7	RFIOP	Analog	Pos RF Differential I/O
8	RFION	Analog	Neg RF Differential I/O
9	SDIO_SPI_CFG	Digital Input	Tie to 1 for SPI, 0 for SDIO
10	GPIO0/HOST_WAKE	Digital I/O, Programmable Pull-Up	GPIO0/SLEEP Mode Control
11	GPIO2/IRON	Digital I/O, Programmable Pull-Up	GPIO2/Device Interrupt
12	SD_DAT3	Digital I/O, Programmable Pull-Up	SDIO Data3
13	SD_DAT2/SPI_RXD	Digital I/O, Programmable Pull-Up	SDIO Data2/SPI Data RX
14	VDDC	Power	Digital Core Power Supply (see Section 9.1)
15	VDDIO	Power	Digital I/O Power Supply (see Section 9.1)
16	SD_DAT1/SPI_SSN	Digital I/O, Programmable Pull-Up	SDIO Data1/SPI Slave Select
17	SD_DAT0/SPI_TXD	Digital I/O, Programmable Pull-Up	SDIO Data0/SPI Data TX
18	SD_CMD/SPI_SCK	Digital I/O, Programmable Pull-Up	SDIO Command/SPI Clock
19	SD_CLK	Digital I/O, Programmable Pull-Up	SDIO Clock

Pin #	Pin Name	Pin Type	Description
20	VBATT_BUCK	Power	Battery Supply for DC/DC Converter (see Section 9.1)
21	VSW	Power	Switching output of DC/DC Converter (see Section 9.1)
22	VREG_BUCK	Power	Core Power from DC/DC Converter (see Section 9.1)
23	CHIP_EN	Analog	PMU Enable
24	GPIO1/RTC_CLK	Digital I/O, Programmable Pull-Up	GPIO1/32kHz Clock Input
25	TEST_MODE	Digital Input	Test Mode – Customer Tie to GND
26	VDDIO	Power	Digital I/O Power Supply (see Section 9.1)
27	VDDC	Power	Digital Core Power Supply (see Section 9.1)
28	GPIO3	Digital I/O, Programmable Pull-Up	GPIO3
29	GPIO4	Digital I/O, Programmable Pull-Up	GPIO4
30	GPIO5	Digital I/O, Programmable Pull-Up	GPIO5
31	GPIO6	Digital I/O, Programmable Pull-Up	GPIO6
32	I2C_SCL	Digital I/O, Programmable Pull-Up	I2C Slave Clock (high-drive pad, see Table 4-3)
33	I2C_SDA	Digital I/O, Programmable Pull-Up	I2C Slave Data (high-drive pad, see Table 4-3)
34	RESETN	Digital Input	Active-Low Hard Reset
35	XO_N	Analog	Crystal Oscillator N
36	XO_P	Analog	Crystal Oscillator P
37	VDD_SXDIG	Power	SX Power Supply (see Section 9.1)
38	VDD_VCO	Power	VCO Power Supply (see Section 9.1)
39	VDDIO_A	Power	Tuner VDDIO Power Supply (see Section 9.1)
40	TP_N	Analog	Test Pin/Customer No Connect
41	PADDLE VSS	Power	Connect to System Board Ground

## 3.2 Package Description

The ATWINC1500B QFN package information is provided in [Table 3-2](#).

**Table 3-2. QFN Package Information**

Parameter	Value	Units	Tolerance
Package Size	5x5	mm	±0.1mm
QFN Pad Count	40		
Total Thickness	0.85	mm	±0.05mm
QFN Pad Pitch	0.40		
Pad Width	0.20		
Exposed Pad size	3.7x3.7	mm	

The ATWINC1500B 40L QFN package view is shown in [Figure 3-2](#).

Figure 3-2. QFN Package

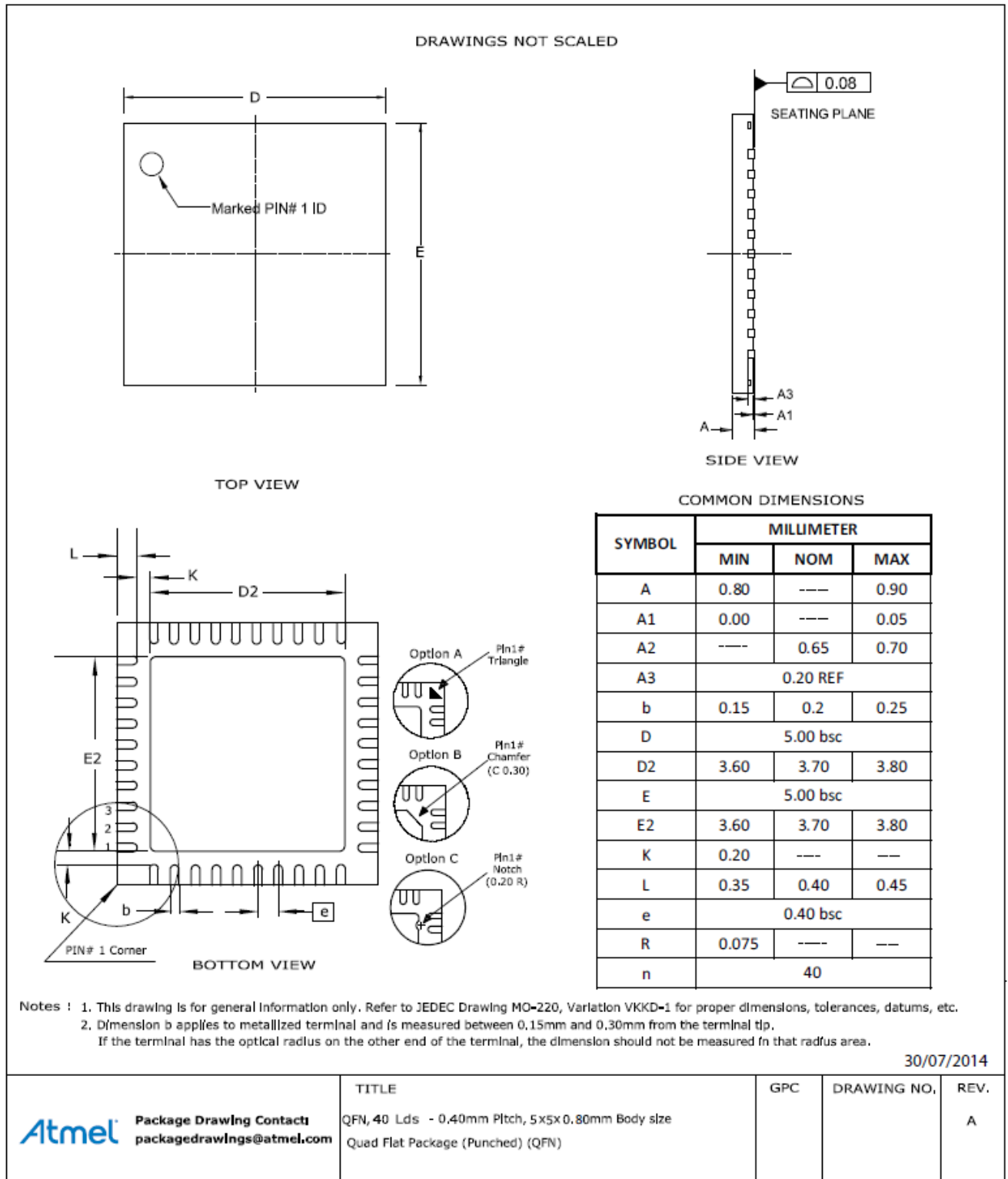

The QFN package is a qualified Green Package.



## 4 Electrical Specifications

### 4.1 Absolute Ratings

Table 4-1. Absolute Maximum Ratings

Characteristic	Symbol	Min.	Max.	Unit
Core Supply Voltage	VDDC	-0.3	1.5	V
I/O Supply Voltage	VDDIO	-0.3	5.0	
Battery Supply Voltage	VBATT	-0.3	5.0	
Digital Input Voltage	VIN	-0.3	VDDIO	
Analog Input Voltage	VESDHBM	-0.3	1.5	
ESD Human Body Model		-1000, -2000 (see notes below)	+1000, +2000 (see notes below)	
Storage Temperature	TA	-65	150	°C
Junction Temperature			125	
RF input power max			23	dBm

- Notes:
1.  $V_{IN}$  corresponds to all the digital pins.
  2.  $V_{AIN}$  corresponds to the following analog pins: VDD\_RF\_RX, VDD\_RF\_TX, VDD\_AMS, RFIOP, RFION, XO\_N, XO\_P, VDD\_SXDIG, VDD\_VCO.
  3. For  $V_{ESDHBM}$ , each pin is classified as Class 1, or Class 2, or both:
    - The Class 1 pins include all the pins (both analog and digital)
    - The Class 2 pins are all digital pins only
    - $V_{ESDHBM}$  is  $\pm 1kV$  for Class1 pins.  $V_{ESDHBM}$  is  $\pm 2kV$  for Class2 pins

### 4.2 Recommended Operating Conditions

Table 4-2. Recommended Operating Conditions

Characteristics	Symbol	Min.	Typ.	Max.	Unit
I/O Supply Voltage	VDDIO	2.7	3.3	3.6	V
Battery Supply Voltage	VBATT	3.0	3.6	4.2	
Operating Temperature		-40		85	°C

- Notes:
1. I/O supply voltage is applied to the following pins: VDDIO\_A, VDDIO.
  2. Battery supply voltage is applied to following pins: VDD\_BATT\_PPA, VDD\_BATT\_PA, VBATT\_BUCK.
  3. Refer to Section 9.1 and Table 9-3 for the details of power connections.

## 4.3 DC Electrical Characteristics

Table 4-3 provides the DC characteristics for the ATWINC1500B digital pads.

Table 4-3. Electrical Characteristics

Characteristic	Min.	Typ.	Max.	Unit
Input Low Voltage $V_{IL}$	-0.30		0.65	V
Input High Voltage $V_{IH}$	VDDIO-0.60		VDDIO+0.30	
Output Low Voltage $V_{OL}$			0.45	
Output High Voltage $V_{OH}$	VDDIO-0.50			
Output Loading			20	pF
Digital Input Load			6	
Pad Drive Strength (regular pads <sup>1</sup> )	8	13.5		mA
Pad Drive Strength (high-drive pads <sup>1</sup> )	16	27		

Note: 1. The following are high-drive pads: I2C\_SCL, I2C\_SDA; all other pads are regular.

## 5 Clocking

### 5.1 Crystal Oscillator

Table 5-1. Crystal Oscillator Parameters

Parameter	Min.	Typ.	Max.	Unit
Crystal Resonant Frequency	12	26	40	MHz
Crystal Equivalent Series Resistance		50	150	$\Omega$
Stability – Initial Offset <sup>1</sup>	-100		100	ppm
Stability - Temperature and Aging	-25		25	

Note: 1. Initial offset must be calibrated to maintain  $\pm 25$ ppm in all operating conditions. This calibration is performed during final production testing.

The block diagram in Figure 5-1(a) shows how the internal Crystal Oscillator (XO) is connected to the external crystal. The XO has 5pF internal capacitance on each terminal XO\_P and XO\_N. To bypass the crystal oscillator with an external reference, an external signal capable of driving 5pF can be applied to the XO\_N terminal as shown Figure 5-1(b).

**Figure 5-1. XO Connections**

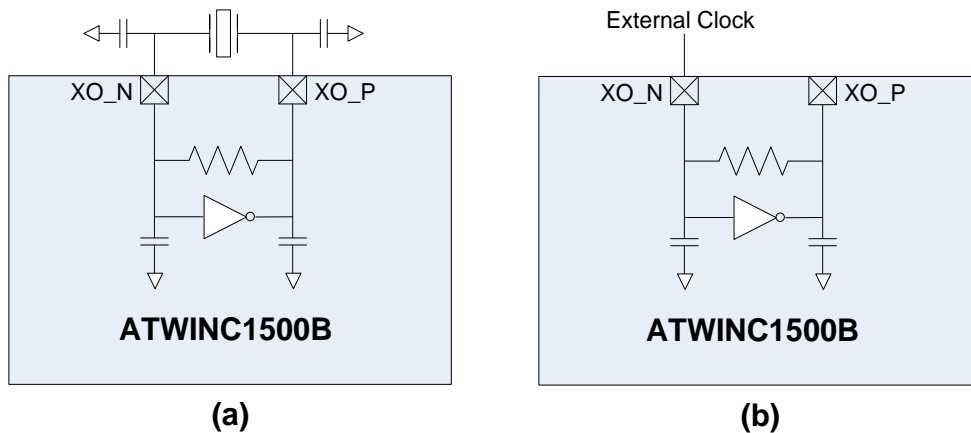

(a) Crystal Oscillator is Used

(b) Crystal Oscillator is Bypassed

Table 5-2 specifies the electrical and performance requirements for the external clock.

**Table 5-2. Bypass Clock Specification**

Parameter	Min.	Max.	Unit	Comments
Oscillation frequency	12	32	MHz	Must be able to drive 5pF load @ desired frequency
Voltage swing	0.5	1.2	Vpp	Must be AC coupled
Stability – Temperature and Aging	-25	+25	ppm	
Phase Noise		-130	dBc/Hz	At 10kHz offset
Jitter(RMS)		<1psec		Based on integrated phase noise spectrum from 1kHz to 1MHz

## 5.2 Low Power Oscillator

ATWINC1500B has an internally-generated 32kHz clock to provide timing information for various sleep functions. Alternatively, ATWINC1500B allows for an external 32kHz clock to be used for this purpose, which is provided through Pin 24 (RTC\_CLK). Software selects whether the internal clock or external clock is used.

The internal low-power clock is ring-oscillator based and has accuracy within 10,000ppm. When using the internal low-power clock, the advance wakeup time in beacon monitoring mode has to be increased by about 1% of the sleep time to compensate for the oscillator inaccuracy. For example, for the DTIM interval value of 1, wakeup time has to be increased by 1ms.

For any application targeting very low power consumption, an external 32kHz RTC clock should be used.

## 6 CPU and Memory Subsystems

### 6.1 Processor

ATWINC1500B has a Cortus APS3 32-bit processor. This processor performs many of the MAC functions, including but not limited to association, authentication, power management, security key management, and MSDU aggregation/de-aggregation. In addition, the processor provides flexibility for various modes of operation, such as STA and AP modes.

### 6.2 Memory Subsystem

The APS3 core uses a 128KB instruction/boot ROM along with a 160KB instruction RAM and a 64KB data RAM. ATWINC1500B also has 4Mb of Flash memory, which can be used for system software. In addition, the device uses a 128KB shared RAM, accessible by the processor and MAC, which allows the APS3 core to perform various data management tasks on the TX and RX data packets.

### 6.3 Non-Volatile Memory (eFuse)

ATWINC1500B has 768 bits of non-volatile eFuse memory that can be read by the CPU after device reset. This non-volatile one-time-programmable (OTP) memory can be used to store customer-specific parameters, such as MAC address; various calibration information, such as TX power, crystal frequency offset, etc.; and other software-specific configuration parameters. The eFuse is partitioned into six 128-bit banks. Each bank has the same bit map, which is shown in Figure 6-1. The purpose of the first 80 bits in each bank is fixed, and the remaining 48 bits are general-purpose software dependent bits, or reserved for future use. Since each bank can be programmed independently, this allows for several updates of the device parameters following the initial programming, e.g. updating MAC address. Refer to ATWINC1500B Programming Guide for the eFuse programming instructions.

Figure 6-1. eFuse Bit Map

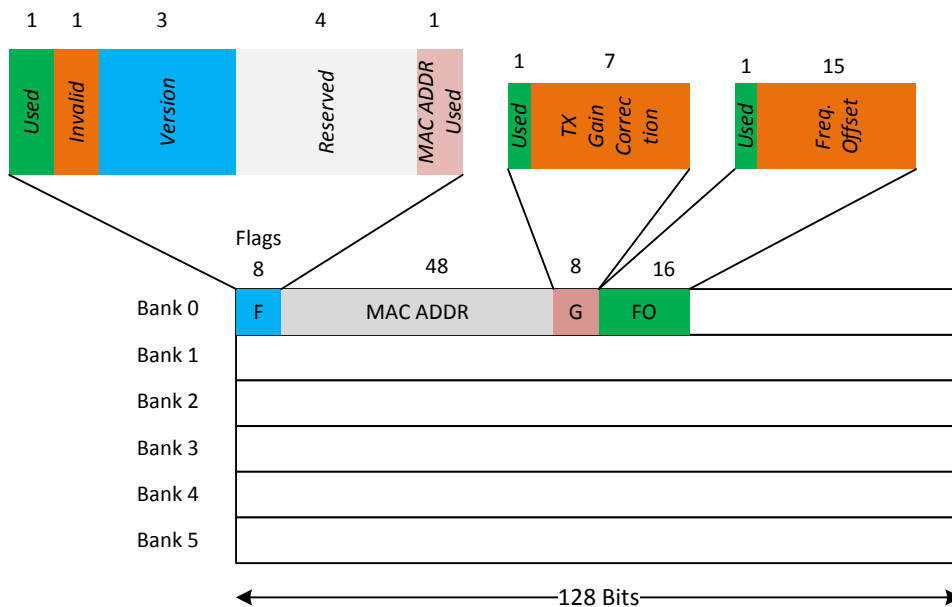

## 7 WLAN Subsystem

The WLAN subsystem is composed of the Media Access Controller (MAC) and the Physical Layer (PHY). The following two subsections describe the MAC and PHY in detail.

### 7.1 MAC

#### 7.1.1 Features

The ATWINC1500B IEEE 802.11 MAC supports the following functions:

- IEEE 802.11b/g/n
- IEEE 802.11e WMM QoS EDCA/PCF multiple access categories traffic scheduling
- Advanced IEEE 802.11n features:
  - Transmission and reception of aggregated MPDUs (A-MPDU)
  - Transmission and reception of aggregated MSDUs (A-MSDU)
  - Immediate Block Acknowledgement
  - Reduced Interframe Spacing (RIFS)
- Support for IEEE 802.11i and WPA security with key management
  - WEP 64/128
  - WPA-TKIP
  - 128-bit WPA2 CCMP (AES)
- Support for WAPI security
- Advanced power management
  - Standard 802.11 Power Save Mode
  - Wi-Fi Alliance WMM-PS (U-APSD)
- RTS-CTS and CTS-self support
- Supports either STA or AP mode in the infrastructure basic service set mode
- Supports independent basic service set (IBSS)

#### 7.1.2 Description

The ATWINC1500B MAC is designed to operate at low power while providing high data throughput. The IEEE 802.11 MAC functions are implemented with a combination of dedicated datapath engines, hardwired control logic, and a low-power, high-efficiency microprocessor. The combination of dedicated logic with a programmable processor provides optimal power efficiency and real-time response while providing the flexibility to accommodate evolving standards and future feature enhancements.

Dedicated datapath engines are used to implement data path functions with heavy computational. For example, an FCS engine checks the CRC of the transmitting and receiving packets, and a cipher engine performs all the required encryption and decryption operations for the WEP, WPA-TKIP, WPA2 CCMP-AES, and WAPI security requirements.

Control functions which have real-time requirements are implemented using hardwired control logic modules. These logic modules offer real-time response while maintaining configurability via the processor. Examples of hardwired control logic modules are the channel access control module (implements EDCA/HCCA, Beacon TX control, interframe spacing, etc.), protocol timer module (responsible for the Network Access Vector, back-off timing, timing synchronization function, and slot management), MPDU handling module, aggregation/de-aggregation module, block ACK controller (implements the protocol requirements for burst block communication), and TX/RX control FSMs (coordinate data movement between PHY-MAC interface, cipher engine, and the DMA interface to the TX/RX FIFOs).

The MAC functions implemented solely in software on the microprocessor have the following characteristics:

- Functions with high memory requirements or complex data structures. Examples are association table management and power save queuing.
- Functions with low computational load or without critical real-time requirements. Examples are authentication and association.
- Functions which need flexibility and upgradeability. Examples are beacon frame processing and QoS scheduling.

## 7.2 PHY

### 7.2.1 Features

The ATWINC1500B IEEE802.11 PHY supports the following functions:

- Single antenna 1x1 stream in 20MHz channels
- Supports IEEE 802.11b DSSS-CCK modulation: 1, 2, 5.5, 11Mbps
- Supports IEEE 802.11g OFDM modulation: 6, 9, 12, 18, 24, 36, 48, 54Mbps
- Supports IEEE 802.11n HT modulations MCS0-7, 20MHz, 800 and 400ns guard interval: 6.5, 7.2, 13.0, 14.4, 19.5, 21.7, 26.0, 28.9, 39.0, 43.3, 52.0, 57.8, 58.5, 65.0, 72.2Mbps
- IEEE 802.11n mixed mode operation
- Per packet TX power control
- Advanced channel estimation/equalization, automatic gain control, CCA, carrier/symbol recovery, and frame detection

### 7.2.2 Description

The ATWINC1500B WLAN PHY is designed to achieve reliable and power-efficient physical layer communication specified by IEEE 802.11b/g/n in single stream mode with 20MHz bandwidth. Advanced algorithms have been employed to achieve maximum throughput in a real world communication environment with impairments and interference. The PHY implements all the required functions such as FFT, filtering, FEC (Viterbi decoder), frequency and timing acquisition and tracking, channel estimation and equalization, carrier sensing and clear channel assessment, as well as the automatic gain control.

## 7.3 Radio

### 7.3.1 Receiver Performance

Radio Performance under Typical Conditions: VBATT=3.6V; VDDIO=3.3V; Temp: 25°C.

**Table 7-1. Receiver Performance**

Parameter	Description	Min.	Typ.	Max.	Unit
Frequency		2,412		2,484	MHz
Sensitivity 802.11b	1Mbps DSS		-98		dBm
	2Mbps DSS		-94		
	5.5Mbps DSS		-92		
	11Mbps DSS		-88		
Sensitivity 802.11g	6Mbps OFDM		-90		
	9Mbps OFDM		-89		

Parameter	Description	Min.	Typ.	Max.	Unit
	12Mbps OFDM		-88		dBm
	18Mbps OFDM		-85		
	24Mbps OFDM		-83		
	36Mbps OFDM		-80		
	48Mbps OFDM		-76		
	54Mbps OFDM		-74		
Sensitivity 802.11n (BW=20MHz)	MCS 0		-89		
	MCS 1		-87		
	MCS 2		-85		
	MCS 3		-82		
	MCS 4		-77		
	MCS 5		-74		
	MCS 6		-72		
Maximum Receive Signal Level	MCS 7		-70.5		
	1-11Mbps DSS		0		
	6-54Mbps OFDM		0		
Adjacent Channel Re- jection	MCS 0 – 7		0		
	1Mbps DSS (30MHz offset)		50		
	11Mbps DSS (25MHz offset)		43		
	6Mbps OFDM (25MHz offset)		40		
	54Mbps OFDM (25MHz offset)		25		
	MCS 0 – 20MHz BW (25MHz offset)		40		
Cellular Blocker Im- munity	MCS 7 – 20MHz BW (25MHz offset)		20		
	776-794MHz CDMA		-14		
	824-849MHz GSM		-10		
	880-915MHz GSM		-10		
	1710-1785MHz GSM		-15		
	1850-1910MHz GSM		-15		
	1850-1910MHz WCDMA		-24		
1920-1980MHz WCDMA		-24			

### 7.3.2 Transmitter Performance

Radio Performance under Typical Conditions: VBATT=3.6V; VDDIO=3.3V; Temp: 25°C.

**Table 7-2. Transmitter Performance**

Parameter	Description	Min.	Typ.	Max.	Unit
Frequency		2,412		2,484	MHz
Output Power <sup>1</sup> , ON_Transmit_High_Power Mode	802.11b 1Mbps		19.5		dBm
	802.11b 11Mbps		20.5		
	802.11g 6Mbps		19.5		
	802.11g 54Mbps		17.5		
	802.11n MCS 0		18.0		
	802.11n MCS 7		15.5		
Output Power <sup>1</sup> , ON_Transmit_Low_Power Mode	802.11b 1Mbps		18.0		dBm
	802.11b 11Mbps		18.5		
	802.11g 6-18Mbps		17.0		
	802.11g >18Mbps		N/A		
	802.11n MCS 0-3		15.5		
	802.11n >MCS 3		N/A		
TX Power Accuracy			±1.5 <sup>2</sup>		dB
Carrier Suppression			30.0		dBc
Out of Band Transmit Power	76-108		-125		dBm/Hz
	776-794		-125		
	869-960		-125		
	925-960		-125		
	1570-1580		-125		
	1805-1880		-125		
	1930-1990		-125		
2110-2170		-125			
Harmonic Output Power	2 <sup>nd</sup>		-33		dBm/Hz
	3 <sup>rd</sup>		-38		

- Notes: 1. Measured at 802.11 spec compliant EVM/Spectral Mask.  
2. Measured at RF Pin assuming 50Ω differential.



## 8 External Interfaces

ATWINC1500B external interfaces include:

- I<sup>2</sup>C Slave for control
- SPI Slave and SDIO Slave for control and data transfer
- I<sup>2</sup>C Master for external EEPROM
- Two UARTs for debug, control, and data transfer
- General Purpose Input/Output (GPIO) pins
- Wi-Fi/Bluetooth coexistence interface

With the exception of the SPI Slave and SDIO Slave host interfaces, which are selected using the dedicated SDIO\_SPI\_CFG pin, the other interfaces can be assigned to various pins by programming the corresponding pin muxing control register for each pin to a specific value between 0 and 6. The default values of these registers are 0, which is GPIO mode. The summary of the available interfaces and their corresponding pin MUX settings is shown in [Table 8-1](#). For specific programming instructions refer to ATWINC1500B Programming Guide.

**Table 8-1. Pin-MUX Matrix of External Interfaces**

Pin Name	Mux 0	Mux 1	Mux 2	Mux3	Mux4	Mux5	Mux6
GPIO0 / HOST_WAKEUP	GPIO_0	I_HOST_WAKEUP		O_UART1_TXD	IO_I2C_MASTER_SCL		IO_COE
GPIO2 / IRQN	GPIO_2	O_IRQN	O_UART1_TXD	I_UART1_RXD			IO_COE
SD_DAT3	GPIO_7	IO_SD_DAT3	IO_I2C_MASTER_SCL	O_UART1_TXD		I_HOST_WAKEUP	IO_COE
SD_DAT2 / SPI_RXD		IO_SD_DAT2	I_SPI_RXD	I_UART1_RXD	O_UART2_TXD		
SD_DAT1 / SPI_SSN		IO_SD_DAT1	IO_SPI_SSN		O_UART2_RTS		
SD_DAT0 / SPI_TXD		IO_SD_DAT0	IO_SPI_TXD		I_UART2_RXD		
SD_CMD / SPI_SCK		IO_SD_CMD	IO_SPI_SCK		I_UART2_CTS	I_RTC_CLK	
SD_CLK	GPIO_8	I_SD_CLK	IO_I2C_MASTER_SDA	I_UART1_RXD		O_UART1_TXD	IO_COE
GPIO1 / RTC_CLK	GPIO_1	I_RTC_CLK	O_UART1_TXD	I_UART1_RXD	IO_I2C_MASTER_SDA		IO_COE
GPIO_3	GPIO_3			I_UART1_RXD		O_UART2_RTS	IO_COE
GPIO_4	GPIO_4		IO_I2C_MASTER_SCL	I_UART2_RXD			IO_COE
GPIO_5	GPIO_5		I_HOST_WAKEUP	O_UART1_TXD		I_UART2_CTS	IO_COE
GPIO_6	GPIO_6		IO_I2C_MASTER_SDA	O_UART2_TXD			IO_COE
I2C_SCL		IO_I2C_SCL	O_UART1_TXD	I_RTC_CLK	IO_I2C_MASTER_SCL		IO_COE
I2C_SDA		IO_I2C_SDA	I_UART1_RXD		IO_I2C_MASTER_SDA		IO_COE

### 8.1 I<sup>2</sup>C Slave Interface

The I<sup>2</sup>C Slave interface, used primarily for control by the host processor, is a two-wire serial interface consisting of a serial data line (SDA, Pin 33) and a serial clock (SCL, Pin 32). It responds to the seven bit address value 0x60. The ATWINC1500B I<sup>2</sup>C supports I<sup>2</sup>C bus Version 2.1 - 2000 and can operate in standard mode (with data rates up to 100Kb/s) and fast mode (with data rates up to 400Kb/s).

The I<sup>2</sup>C Slave is a synchronous serial interface. The SDA line is a bidirectional signal and changes only while the SCL line is low, except for STOP, START, and RESTART conditions. The output drivers are open-drain to perform wire-AND functions on the bus. The maximum number of devices on the bus is limited by only the maximum capacitance specification of 400pF. Data is transmitted in byte packages.

For specific information, refer to the Philips Specification entitled “The I<sup>2</sup>C -Bus Specification, Version 2.1”.

The I<sup>2</sup>C Slave timing is provided in [Figure 8-1](#) and [Table 8-2](#).

**Figure 8-1. I<sup>2</sup>C Slave Timing Diagram**

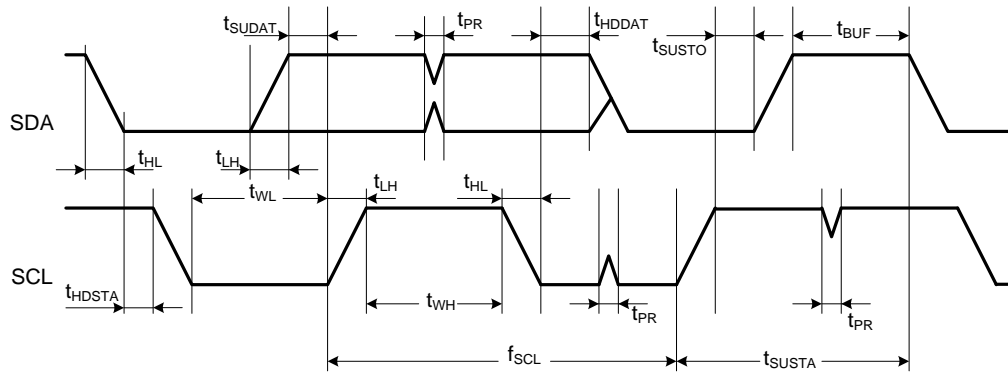

**Table 8-2. I<sup>2</sup>C Slave Timing Parameters**

Parameter	Symbol	Min.	Max.	Units	Remarks
SCL Clock Frequency	$f_{SCL}$	0	400	kHz	
SCL Low Pulse Width	$t_{WL}$	1.3		$\mu$ s	
SCL High Pulse Width	$t_{WH}$	0.6			
SCL, SDA Fall Time	$t_{HL}$		300	ns	This is dictated by external components
SCL, SDA Rise Time	$t_{LH}$		300		
START Setup Time	$t_{SUSTA}$	0.6		$\mu$ s	
START Hold Time	$t_{HDSTA}$	0.6			
SDA Setup Time	$t_{SUDAT}$	100		ns	Slave and Master Default
SDA Hold Time	$t_{HDDAT}$	0 40			Master Programming Option
STOP Setup time	$t_{SUSTO}$	0.6		$\mu$ s	
Bus Free Time Between STOP and START	$t_{BUF}$	1.3			
Glitch Pulse Reject	$t_{PR}$	0	50	ns	

## 8.2 I<sup>2</sup>C Master Interface

ATWINC1500B provides an I<sup>2</sup>C bus master, which is intended primarily for accessing an external EEPROM memory through a software-defined protocol. The I<sup>2</sup>C Master is a two-wire serial interface consisting of a serial data line (SDA) and a serial clock line (SCL). SDA can be configured on one of the following pins: SD\_CLK (pin 19), GPIO1 (pin 24), GPIO6 (pin 31), or I2C\_SDA (pin 33). SCL can be configured on one of the following pins: GPIO0 (pin 10), SD\_DAT3 (pin 12), GPIO4 (pin 29), or I2C\_SCL (pin 32). For more specific instructions refer to ATWINC1500B Programming Guide.

The I<sup>2</sup>C Master interface supports three speeds:

- Standard mode (100kb/s)
- Fast mode (400kb/s)
- High-speed mode (3.4Mb/s)

The timing diagram of the I<sup>2</sup>C Master interface is the same as that of the I<sup>2</sup>C Slave interface (see [Figure 8-1](#)). The timing parameters of I<sup>2</sup>C Master are shown in [Table 8-3](#).

**Table 8-3. I<sup>2</sup>C Master Timing Parameters**

Parameter	Symbol	Standard Mode		Fast Mode		High-Speed Mode		Units
		Min.	Max.	Min.	Max.	Min.	Max.	
SCL Clock Frequency	f <sub>SCL</sub>	0	100	0	400	0	3400	kHz
SCL Low Pulse Width	t <sub>WL</sub>	4.7		1.3		0.16		μs
SCL High Pulse Width	t <sub>WH</sub>	4		0.6		0.06		
SCL Fall Time	t <sub>HLSCL</sub>		300		300	10	40	ns
SDA Fall Time	t <sub>HLSDA</sub>		300		300	10	80	
SCL Rise Time	t <sub>LHSCl</sub>		1000		300	10	40	
SDA Rise Time	t <sub>LHSDA</sub>		1000		300	10	80	
START Setup Time	t <sub>SUSTA</sub>	4.7		0.6		0.16		μs
START Hold Time	t <sub>HDSTA</sub>	4		0.6		0.16		
SDA Setup Time	t <sub>SUDAT</sub>	250		100		10		ns
SDA Hold Time	t <sub>HDDAT</sub>	5		40		0	70	
STOP Setup time	t <sub>SUSTO</sub>	4		0.6		0.16		μs
Bus Free Time Between STOP and START	t <sub>BUF</sub>	4.7		1.3				
Glitch Pulse Reject	t <sub>PR</sub>			0	50			ns

## 8.3 SPI Slave Interface

ATWINC1500B provides a Serial Peripheral Interface (SPI) that operates as a SPI slave. The SPI Slave interface can be used for control and for serial I/O of 802.11 data. The SPI Slave pins are mapped as shown in [Table 8-4](#). The RXD pin is same as Master Output, Slave Input (MOSI), and the TXD pin is same as Master Input, Slave Output (MISO). The SPI Slave is a full-duplex slave-synchronous serial interface that is available immediately following reset when pin 9 (SDIO\_SPI\_CFG) is tied to VDDIO.

**Table 8-4. SPI Slave Interface Pin Mapping**

Pin #	SPI Function
9	CFG: Must be tied to VDDIO
16	SSN: Active Low Slave Select
18	SCK: Serial Clock
13	RXD: Serial Data Receive (MOSI)
17	TXD: Serial Data Transmit (MISO)

When the SPI is not selected, i.e., when SSN is high, the SPI interface will not interfere with data transfers between the serial-master and other serial-slave devices. When the serial slave is not selected, its transmitted data output is buffered, resulting in a high impedance drive onto the serial master receive line.

The SPI Slave interface responds to a protocol that allows an external host to read or write any register in the chip as well as initiate DMA transfers. For the details of the SPI protocol and more specific instructions refer to ATWINC1500B Programming Guide.

The SPI Slave interface supports four standard modes as determined by the Clock Polarity (CPOL) and Clock Phase (CPHA) settings. These modes are illustrated in Table 8-5 and Figure 8-2. The red lines in Figure 8-2 correspond to Clock Phase = 0 and the blue lines correspond to Clock Phase = 1.

**Table 8-5. SPI Slave Modes**

Mode	CPOL	CPHA
0	0	0
1	0	1
2	1	0
3	1	1

**Figure 8-2. SPI Slave Clock Polarity and Clock Phase Timing**

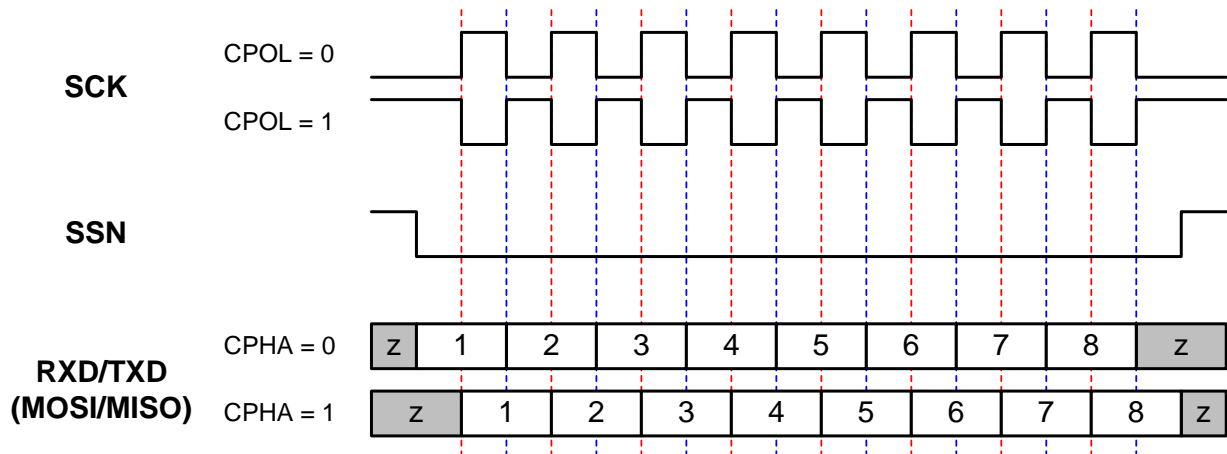

The SPI Slave timing is provided in [Figure 8-3](#) and [Table 8-6](#).

**Figure 8-3. SPI Slave Timing Diagram**

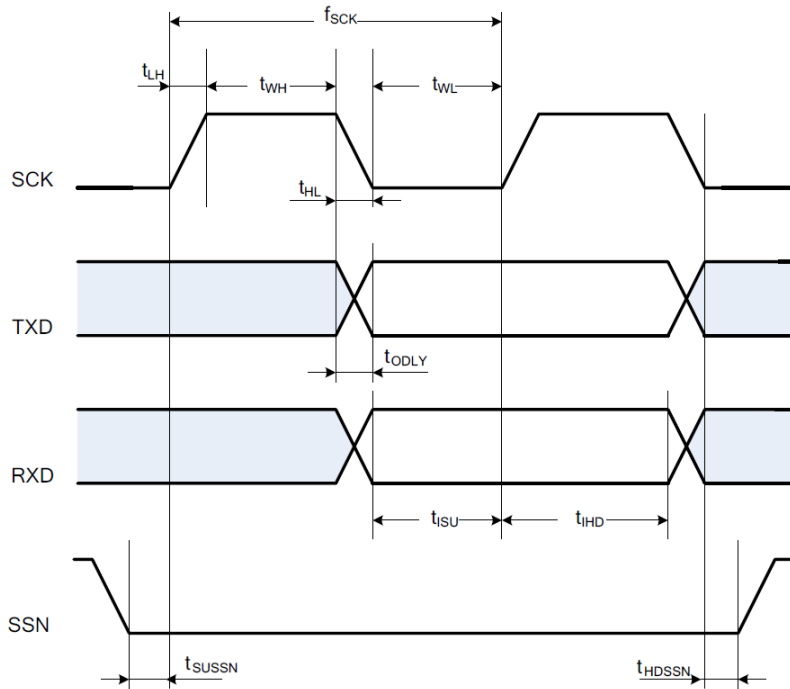

**Table 8-6. SPI Slave Timing Parameters**

Parameter	Symbol	Min.	Max.	Units
Clock Input Frequency	$f_{SCK}$		48	MHz
Clock Low Pulse Width	$t_{WL}$	5		ns
Clock High Pulse Width	$t_{WH}$	5		
Clock Rise Time	$t_{LH}$		5	
Clock Fall Time	$t_{HL}$		5	
Input Setup Time	$t_{ISU}$	5		
Input Hold Time	$t_{IHD}$	5		
Output Delay	$t_{ODLY}$	0	20	
Slave Select Setup Time	$t_{SUSN}$	5		
Slave Select Hold Time	$t_{HDSSN}$	5		

## 8.4 UART

ATWINC1500B has two Universal Asynchronous Receiver/Transmitter (UART) interfaces for serial communication: UART1 and UART2. The UARTs are compatible with the RS-232 standard, where ATWINC1500B operates as Data Terminal Equipment (DTE).

UART1 has a 2-pin interface without flow control (RXD/TXD), where RXD (received data) can be enabled on one of five alternative pins and TXD (transmitted data) can be enabled on one of seven alternative pins by programming their corresponding pin MUX control registers (see [Table 8-1](#)). UART2 has a 4-pin interface with flow control (RXD/TXD/CTS/RTS), where RXD (received data) can be enabled on one of two alternative pins, TXD (transmitted data) can be enabled on one of two alternative pins, CTS (clear to send) can be enabled on one of two alternative pins, and RTS (request to send) can be enabled on one of two alternative pins by programming their corresponding pin MUX control registers (see [Table 8-1](#)).

Both UARTs feature programmable baud rate generation with fractional clock division, which allows transmission and reception at a wide variety of standard and non-standard baud rates. The UART input clock is selectable between  $XO \times 2$ ,  $XO$ ,  $XO \div 2$ , and  $XO \div 4$ , which corresponds to 52MHz, 26MHz, 13MHz, and 6.5MHz for the typical  $XO$  frequency (26MHz). The clock divider value is programmable as 13 integer bits and 3 fractional bits (with 8.0 being the smallest recommended value for normal operation). This results in the maximum baud rate of  $52\text{MHz}/8.0 = 6.5\text{Mbd}$  for typical  $XO$  frequency.

Both UARTs can be configured for seven or eight bit operation, with or without parity, with four different parity types (odd, even, mark, or space), and with one or two stop bits. They also have RX and TX FIFOs, which ensure reliable high speed reception and low software overhead transmission. FIFO size is 4x8 for both RX and TX direction. The UARTs also have status registers showing the number of received characters available in the FIFO and various error conditions, as well the ability to generate interrupts based on these status bits.

UART2 supports standard flow control using CTS and RTS signals – UART2 can be programmed to enable or disable flow control. CTS is an active low input. When it is asserted (low) UART2 will transmit data; when it becomes de-asserted (high) UART2 will finish transmitting the current byte (if it is in progress) and will not resume transmitting until CTS becomes asserted again. RTS is an active low output. It becomes asserted (low) when the RX FIFO in UART2 has space; it becomes de-asserted (high) when there is not enough space in the RX FIFO.

An example of UART receiving or transmitting a single packet is shown in [Figure 8-4](#). This example shows 7-bit data (0x45), odd parity, and two stop bits.

For more specific instructions refer to ATWINC1500B Programming Guide.

**Figure 8-4. Example of UART RX or TX Packet**

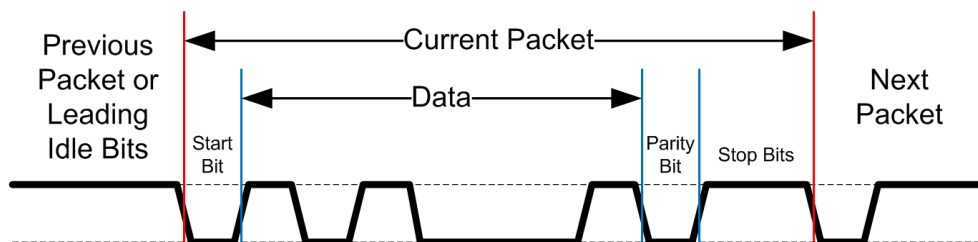

## 8.5 Wi-Fi/Bluetooth Coexistence

ATWINC1500 supports 2-wire and 3-wire Wi-Fi/Bluetooth Coexistence signaling conforming to the IEEE 802.15.2-2003 standard, Part 15.2. The type of coexistence interface used (2 or 3 wire) is chosen to be compatible with the specific Bluetooth device used in a given application. Coexistence interface can be enabled on several alternative pins by programming their corresponding pin MUX control register to 6 (see [Table 8-1](#), where any pin marked “IO\_COE” in the “Mux6” column can be configured for any function of the

coexistence interface). [Table 8-7](#) shows a usage example of the 2-wire interface using the GPIO3 and GPIO4 pins; 3-wire interface using the GPIO3, GPIO4, and GPIO5 pins; for more specific instructions on configuring Coexistence refer to ATWINC1500 Programming Guide.

**Table 8-7. Coexistence Pin Assignment Example**

Pin Name	Pin #	Function	Target	2-wire	3-wire
GPIO3	28	BT_Req	BT is requesting to access the medium to transmit or receive. Goes high on TX or RX slot.	Used	Used
GPIO4	29	WL_Act	Device response to the BT request. High - BT_req is denied and BT slot blocked.	Used	Used
GPIO5	30	BT_Pri	Priority of the BT packets in the requested slot. High to indicate high priority and low for normal.	Not Used	Used
GPIO6	31	Ant_SW	Direct control on Antenna (coex bypass).	Optional	Optional

## 8.6 GPIOs

Nine General Purpose Input/Output (GPIO) pins, labeled GPIO 0-8, are available to allow for application specific functions. Each GPIO pin can be programmed as an input (the value of the pin can be read by the host or internal processor) or as an output (the output values can be programmed by the host or internal processor), where the default mode after power-up is input. GPIOs 7 and 8 are only available when the host does not use the SDIO interface, which shares two of its pins with these GPIOs. Therefore, for SDIO-based applications, seven GPIOs (0-6) are available. For more specific usage instructions refer to ATWINC1500B Programming Guide.

## 9 Power Management

### 9.1 Power Architecture

ATWINC1500B uses an innovative power architecture to eliminate the need for external regulators and reduce the number of off-chip components. This architecture is shown in Figure 9-1. The Power Management Unit (PMU) has a DC/DC Converter that converts VBATT to the core supply used by the digital and RF/AMS blocks. Table 9-1 shows the typical values for the digital and RF/AMS core voltages. The PA and eFuse are supplied by dedicated LDOs, and the VCO is supplied by a separate LDO structure.

Figure 9-1. Power Architecture

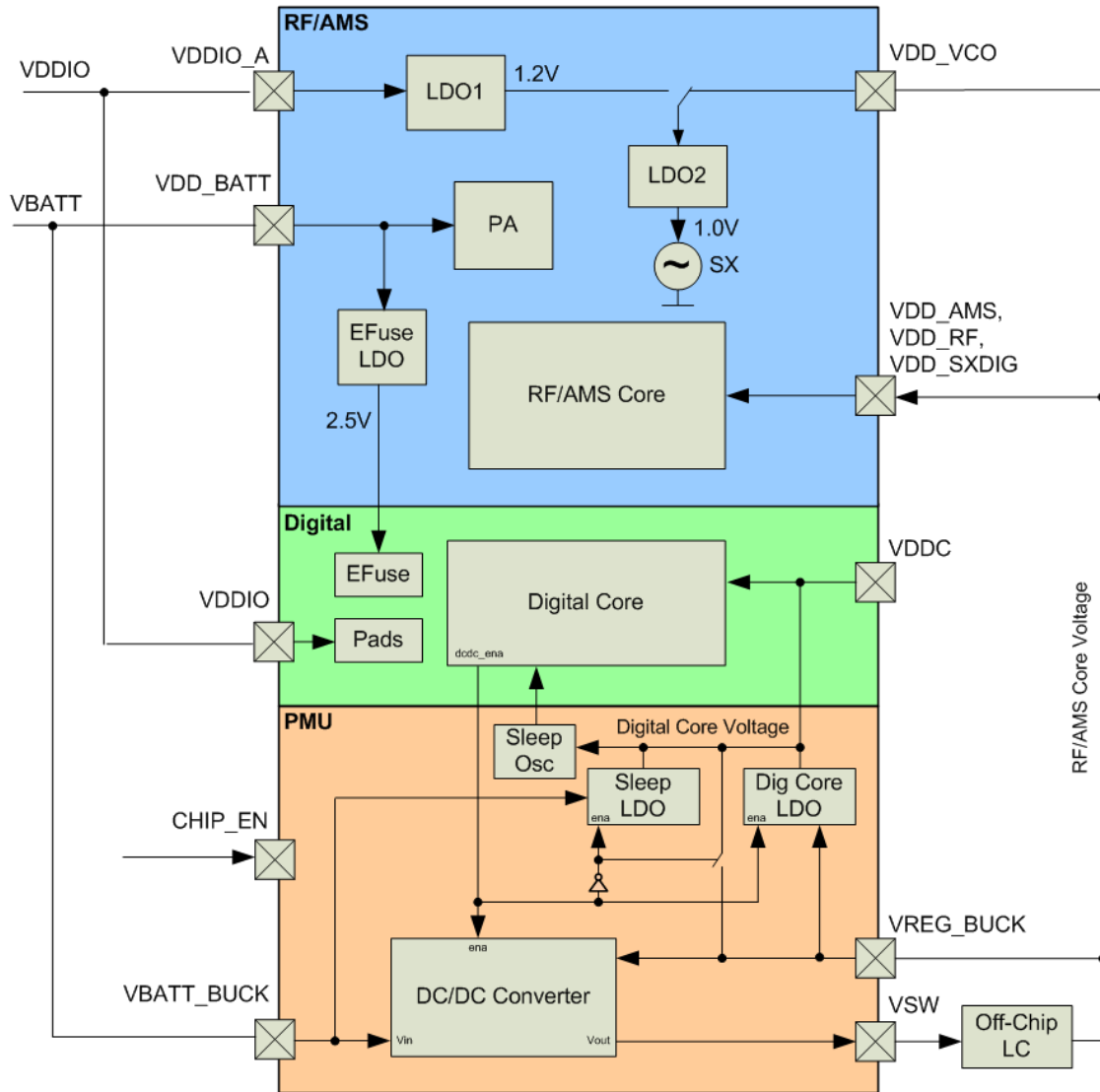

Table 9-1. PMU Output Voltages

Parameter	Typical
RF/AMS Core Voltage (VREG_BUCK)	1.35V
Digital Core Voltage (VDDC)	1.10V



The power connections in [Figure 9-1](#) provide a conceptual framework for understanding the ATWINC1500B power architecture. Refer to the reference design in [Chapter 10](#) for an example of power supply connections, including proper isolation of the supplies used by the digital and RF/AMS blocks.

## 9.2 Power Consumption

### 9.2.1 Description of Device States

ATWINC1500B has several Device States:

- ON\_Transmit\_High\_Power – Device is actively transmitting an 802.11 signal. Highest output power and nominal current consumption
- ON\_Transmit\_Low\_Power – Device is actively transmitting an 802.11 signal. Reduced output power and reduced current consumption
- ON\_Receive\_High\_Power – Device is actively receiving an 802.11 signal. Lowest sensitivity and nominal current consumption
- ON\_Receive\_Low\_Power – Device is actively receiving an 802.11 signal. Degraded sensitivity and reduced current consumption
- ON\_Doze – Device is on but is neither transmitting nor receiving
- Power\_Down – Device core supply off (Leakage)
- IDLE connect – Device is connected with 1 DTIM beacon interval

The following pins are used to switch between the ON and Power\_Down states:

- CHIP\_EN – Device pin (pin #23) used to enable DC/DC Converter
- VDDIO – I/O supply voltage from external supply

In the ON states, VDDIO is on and CHIP\_EN is high (at VDDIO voltage level). To switch between the ON states and Power\_Down state CHIP\_EN has to change between high and low (GND) voltage. When VDDIO is off and CHIP\_EN is low, the chip is powered off with no leakage (also see [Section 9.2.3](#)).

### 9.2.2 Current Consumption in Various Device States

**Table 9-2. Current Consumption**

Device State	Code Rate	Output Power, dBm	Current Consumption <sup>1,2</sup>	
			IVBATT	IVDDIO
ON_Transmit_High_Power	802.11b 1Mbps	19.5	294 mA	22mA
	802.11b 11Mbps	20.5	290 mA	22mA
	802.11g 6Mbps	19.5	292 mA	22mA
	802.11g 54Mbps	17.5	250 mA	22mA
	802.11n MCS 0	18.0	289 mA	22mA
	802.11n MCS 7	15.5	244 mA	22mA
ON_Transmit_Low_Power	802.11b 1Mbps	18,0	233 mA	2mA
	802.11b 11Mbps	18.5	231 mA	2mA
	802.11g 6-18Mbps	17.0	146 mA	2mA
	802.11g >18Mbps	N/A	N/A	N/A
	802.11n MCS 0-3	15.5	132 mA	2mA

Device State	Code Rate	Output Power, dBm	Current Consumption <sup>1,2</sup>	
			IVBATT	IVDDIO
	802.11n >MCS 3	N/A	N/A	N/A
ON_Receive_High_Power	802.11b 1Mbps	N/A	52.5mA	22mA
	802.11b 11Mbps	N/A	52.5mA	22mA
	802.11g 6Mbps	N/A	55.0mA	22mA
	802.11g 54Mbps	N/A	57.5mA	22mA
	802.11n MCS 0	N/A	54.0mA	22mA
	802.11n MCS 7	N/A	58.5mA	22mA
ON_Receive_Low_Power	802.11b 1Mbps	N/A	63.5mA	2.4mA
	802.11b 11Mbps	N/A	64.2mA	2.4 mA
	802.11g 6Mbps	N/A	65.4mA	2.4mA
	802.11g 54Mbps	N/A	65.4mA	2.4mA
	802.11n MCS 0	N/A	65.6mA	2.4mA
	802.11n MCS 7	N/A	70.1mA	2.4mA
ON_Doze	N/A	N/A	280µA	<10µA
Power_Down	N/A	N/A	<0.5µA	<3.5µA

Note: 1. Conditions: VBATT @3.6V, VDDIO @2.8V, 25°C  
2. Power consumption numbers are preliminary

### 9.2.3 Restrictions for Power States

When no power supplied to the device, i.e., the DC/DC Converter output and VDDIO are both off (at ground potential). In this case, a voltage cannot be applied to the device pins because each pin contains an ESD diode from the pin to supply. This diode will turn on when voltage higher than one diode-drop is supplied to the pin.

If a voltage must be applied to the signal pads while the chip is in a low power state, the VDDIO supply must be on, so the SLEEP or Power\_Down state must be used.

Similarly, to prevent the pin-to-ground diode from turning on, do not apply a voltage that is more than one diode-drop below ground to any pin.

## 9.3 Power-Up/Down Sequence

The power-up/down sequence for ATWINC1500 is shown in [Figure 9-2](#). The timing parameters are provided in [Table 9-3](#).

**Figure 9-2. Power Up/Down Sequence**

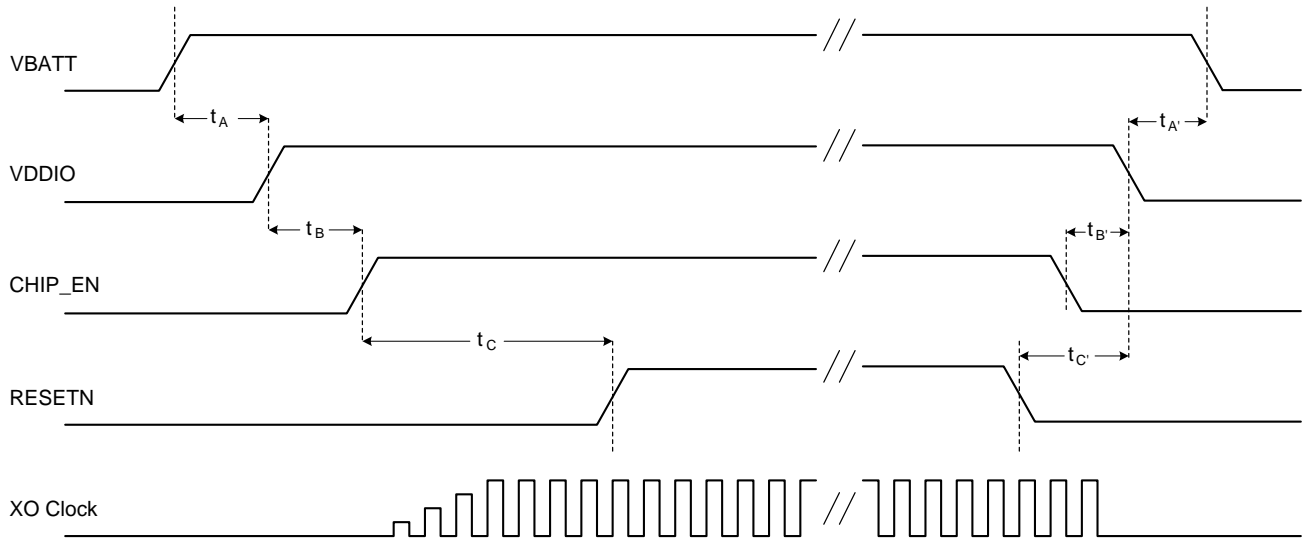

**Table 9-3. Power-Up/Down Sequence Timing**

Parameter	Min.	Max.	Unit	Description	Notes
$t_A$	0		ms	VBATT rise to VDDIO rise	VBATT and VDDIO can rise simultaneously or can be tied together. VDDIO must not rise before VBATT.
$t_B$	0			VDDIO rise to CHIP_EN rise	CHIP_EN must not rise before VDDIO. CHIP_EN must be driven high or low, not left floating.
$t_C$	5			CHIP_EN rise to RE-SETN rise	This delay is needed because XO clock must stabilize before RESETN removal. RESETN must be driven high or low, not left floating.
$t_{A'}$	0			VDDIO fall to VBATT fall	VBATT and VDDIO can fall simultaneously or can be tied together. VBATT must not fall before VDDIO.
$t_{B'}$	0			CHIP_EN fall to VDDIO fall	VDDIO must not fall before CHIP_EN. CHIP_EN and RESETN can fall simultaneously.
$t_{C'}$	0			RESETN fall to VDDIO fall	VDDIO must not fall before RESETN. RESETN and CHIP_EN can fall simultaneously.

## 9.4 Digital I/O Pin Behavior during Power-Up Sequences

Table 9-4 represents digital IO Pin states corresponding to device power modes.

**Table 9-4. Digital I/O Pin Behavior in Different Device States**

Device State	VDDIO	CHIP_EN	RESETN	Output Driver	Input Driver	Pull Up/Down Resistor (96kΩ)
Power_Down: core supply off	High	Low	Low	Disabled (Hi-Z)	Disabled	Disabled
Power-On Reset: core supply on, hard reset on	High	High	Low	Disabled (Hi-Z)	Disabled	Enabled
Power-On Default: core supply on, device out of reset but not programmed yet	High	High	High	Disabled (Hi-Z)	Enabled	Enabled
On_Doze/ On_Transmit/ On_Receive: core supply on, device programmed by firmware	High	High	High	Programmed by firmware for each pin: Enabled or Disabled	Opposite of Output Driver state	Programmed by firmware for each pin: Enabled or Disabled

# 10 Reference Design

Figure 10-1. ATWINC1500B Reference Schematic

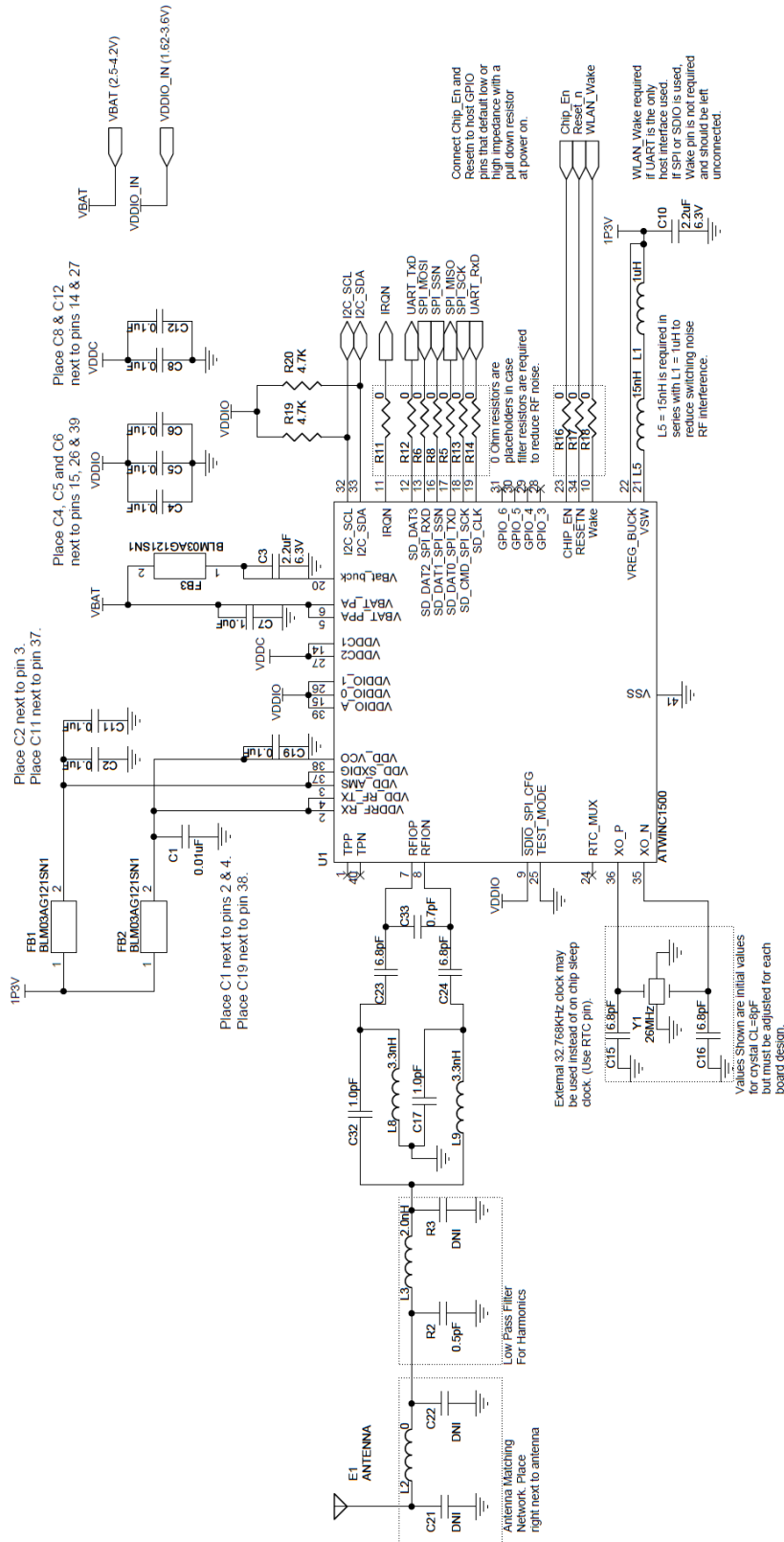

# 11 Reference Documentation and Support

## 11.1 Reference Documents

Atmel offers a set of collateral documentation to ease integration and device ramp.

The following list of documents available on Atmel web or integrated into development tools.

Title	Content
Datasheet	This Document
Design Files Package	User Guide, Schematic, PCB layout, Gerber, BOM & System notes on: RF/Radio Full Test Report, radiation pattern, design guidelines, temperature performance, ESD.
Platform Getting Started Guide	How to use package: Out of the Box starting guide, HW limitations and notes, SW Quick start guidelines.
HW Design Guide	Best practices and recommendations to design a board with the product, Including: Antenna Design for Wi-Fi (layout recommendations, types of antennas, impedance matching, using a power amplifier etc), SPI/UART protocol between Wi-Fi SoC and the Host MCU.
SW Design Guide	Integration guide with clear description of: High level Arch, overview on how to write a networking application, list all API, parameters and structures. Features of the device, SPI/handshake protocol between device and host MCU, with flow/sequence/state diagram, timing.
SW Programmer Guide	Explain in details the flow chart and how to use each API to implement all generic use cases (e.g. start AP, start STA, provisioning, UDP, TCP, http, TLS, p2p, errors management, connection/recovery mechanism/state diagram) - usage & sample App note

For a complete listing of development-support tools & documentation, visit <http://www.atmel.com/>, or contact the nearest Atmel field representative.

## 12 Revision History

Doc Rev.	Date	Comments
42487A	07/2015	<p>DS update to RevB offering</p> <p>Changes from WINC1500A (42353D) to WINC1500B:</p> <ol style="list-style-type: none"> <li>1. Added second UART, increased UART data rates</li> <li>2. Increased instruction RAM size from 128KB to 160KB</li> <li>3. Updated pin mux table: added new options for various interfaces</li> <li>4. Improved description of Coexistence interface</li> <li>5. Added VDD_VCO switch and connection in the power architecture</li> <li>6. Updated power consumption numbers</li> <li>7. Updated reference schematic</li> <li>8. Changed RTC_CLK pad definition from pull-down to pull-up</li> <li>9. Changed pin list to add GPIOs 3,4,5,6 - chip pinout identical WINC and WILC</li> <li>10. Added hardware accelerators in feature list (SSL security, IP checksum, OTA security)</li> <li>11. Modified sections <a href="#">9.2.1</a> and <a href="#">9.2.2</a> to add high-power and low-power modes and current consumption numbers</li> <li>12. Updated radio performance in <a href="#">Table 7-1</a> and <a href="#">Table 7-2</a></li> <li>13. Fixed typos for SPI Slave interface timing in <a href="#">Table 8-6</a></li> <li>14. Fixed typos for battery supply name: changed from VBAT to VBATT</li> <li>15. Corrected <a href="#">Table 8-7</a></li> <li>16. Corrected Power Down and Doze mode current in <a href="#">Table 9-2</a> and in feature list</li> <li>17. Corrected <a href="#">Table 4-3</a> and added high-drive pads reference in <a href="#">Table 3-1</a></li> <li>18. Miscellaneous minor updates and corrections</li> </ol>



Atmel®, Atmel logo and combinations thereof, Enabling Unlimited Possibilities®, and others are registered trademarks or trademarks of Atmel Corporation in U.S. and other countries. ARM®, ARM Connected® logo, and others are the registered trademarks or trademarks of ARM Ltd. Other terms and product names may be trademarks of others.

DISCLAIMER: The information in this document is provided in connection with Atmel products. No license, express or implied, by estoppel or otherwise, to any intellectual property right is granted by this document or in connection with the sale of Atmel products. EXCEPT AS SET FORTH IN THE ATMEL TERMS AND CONDITIONS OF SALES LOCATED ON THE ATMEL WEBSITE, ATMEL ASSUMES NO LIABILITY WHATSOEVER AND DISCLAIMS ANY EXPRESS, IMPLIED OR STATUTORY WARRANTY RELATING TO ITS PRODUCTS INCLUDING, BUT NOT LIMITED TO, THE IMPLIED WARRANTY OF MERCHANTABILITY, FITNESS FOR A PARTICULAR PURPOSE, OR NON-INFRINGEMENT. IN NO EVENT SHALL ATMEL BE LIABLE FOR ANY DIRECT, INDIRECT, CONSEQUENTIAL, PUNITIVE, SPECIAL OR INCIDENTAL DAMAGES (INCLUDING, WITHOUT LIMITATION, DAMAGES FOR LOSS AND PROFITS, BUSINESS INTERRUPTION, OR LOSS OF INFORMATION) ARISING OUT OF THE USE OR INABILITY TO USE THIS DOCUMENT, EVEN IF ATMEL HAS BEEN ADVISED OF THE POSSIBILITY OF SUCH DAMAGES. Atmel makes no representations or warranties with respect to the accuracy or completeness of the contents of this document and reserves the right to make changes to specifications and products descriptions at any time without notice. Atmel does not make any commitment to update the information contained herein. Unless specifically provided otherwise, Atmel products are not suitable for, and shall not be used in, automotive applications. Atmel products are not intended, authorized, or warranted for use as components in applications intended to support or sustain life.

SAFETY-CRITICAL, MILITARY, AND AUTOMOTIVE APPLICATIONS DISCLAIMER: Atmel products are not designed for and will not be used in connection with any applications where the failure of such products would reasonably be expected to result in significant personal injury or death ("Safety-Critical Applications") without an Atmel officer's specific written consent. Safety-Critical Applications include, without limitation, life support devices and systems, equipment or systems for the operation of nuclear facilities and weapons systems. Atmel products are not designed nor intended for use in military or aerospace applications or environments unless specifically designated by Atmel as military-grade. Atmel products are not designed nor intended for use in automotive applications unless specifically designated by Atmel as automotive-grade.